

SID 2000 PREVIEW ISSUE

Information

March 2000
Vol. 16, No. 3

DISPLAY

Official Monthly Publication of the Society for Information Display



Long Beach
California, U.S.A.

- **SID 2000 Preview**
- **The Future of OLEDs**
- **Flat-Faced CRTs**
- **Ruggedizing 20-in. LCDs**
- **A New Video Chipset**

At Optrex, We Can Put Any Bright Idea On Display.



Dot Matrix
Character Module



Color Graphics
LCD Module



Custom
LCD Module

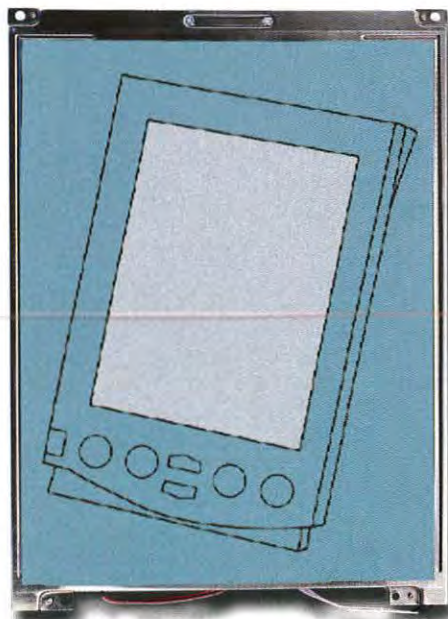

Monochrome
Graphics LCD
Module



OPTREX
AMERICA, INC.

Whatever your LCD needs – standard or custom – Optrex can offer an effective, cost-efficient solution. For over 30 years, manufacturers have relied upon Optrex for technologically-advanced character, monochrome, color and custom LCD configurations. Founded as a joint venture between Asahi Glass Co. LTD. and Mitsubishi Electric Corp., Optrex provides technical design and support through our own sales organization, and through more than 100 sales and distribution offices worldwide. For more information call Optrex, or see your electronics distributor today.

44160 PLYMOUTH OAKS BLVD. • PLYMOUTH, MI 48170 • (734) 416-8500 • FAX: (734) 416-8520

E-mail: lcdinfo@optrexusa.com

See Us at SID '00 Booth 309

Circle no. 4



COVER: From May 14th to 19th the largest SID Symposium and Exhibition ever will be held at the Long Beach Convention and Entertainment Center (foreground). The Queen Mary, the city's most famous attraction, can be seen across the harbor.



Michele and Tom Grimm, courtesy of the Long Beach Area Convention & Visitors Bureau.

For more on what's coming in *Information Display*, and for other news on information-display technology, check the SID Web site on the World Wide Web: <http://www.sid.org>.

Next Month in *Information Display*

SID 2000 Show Issue

- Low-Temp Poly-Si TFT-LCDs
- FED Life and Reliability
- Military Integration of COTS AMLCDs
- SMAU '99 Review
- IDW '99 Review

INFORMATION DISPLAY (ISSN 0362-0972) is published eleven times a year for the Society for Information Display by Palisades Institute for Research Services, Inc., 411 Lafayette Street, 2nd Floor, New York, NY 10003; Leonard H. Klein, President and CEO. EDITORIAL AND BUSINESS OFFICES: Jay Morreale, Managing Editor, Palisades Institute for Research Services, Inc., 411 Lafayette Street, 2nd Floor, New York, NY 10003; telephone 212/460-9700. Send manuscripts to the attention of the Editor, ID, Director of Sales: Michele Klein, Palisades Institute for Research Services, Inc., 411 Lafayette Street, 2nd Floor, New York, NY 10003; 212/460-9700. SID HEADQUARTERS, for correspondence on subscriptions and membership: Society for Information Display, 31 East Julian Street, San Jose, CA 95112; telephone 408/977-1013, fax -1531. SUBSCRIPTIONS: Information Display is distributed without charge to those qualified and to SID members as a benefit of membership (annual dues \$75.00). Subscriptions to others: U.S. & Canada: \$36.00 one year, \$7.50 single copy; elsewhere: \$72.00 one year, \$7.50 single copy. PRINTED by Sheridan Printing Company, Alpha, NJ 08865. Third-class postage paid at Easton, PA. PERMISSIONS: Abstracting is permitted with credit to the source. Libraries are permitted to photocopy beyond the limits of the U.S. copyright law for private use of patrons, providing a fee of \$2.00 per article is paid to the Copyright Clearance Center, 21 Congress Street, Salem, MA 01970 (reference serial code 0362-0972/00/\$1.00 + \$0.00). Instructors are permitted to photocopy isolated articles for noncommercial classroom use without fee. This permission does not apply to any special reports or lists published in this magazine. For other copying, reprint or republication permission, write to Society for Information Display, 31 East Julian Street, San Jose, CA 95112. Copyright © 2000 Society for Information Display. All rights reserved.

Information DISPLAY

MARCH 2000
VOL. 16, NO. 3

- 2 Editorial**
Looking Forward
Kenneth I. Werner
- 4 The Display Continuum**
Ah, Now I Understand ...
Aris Silzars
- 12 The Future of Organic Light-Emitting Diodes**
OLEDs have become the hot new display technology, with many players establishing their positions – but there is still a long way to go before the technology fulfills its potential.
Nigel Bailey
- 20 The Flat Face of CRTs**
Different manufacturers have adopted different approaches to making completely flat CRT screens, and consumers will be seeing a lot of them.
A. A. S. Sluyterman
- 24 Good Things in Small Packages**
National Semiconductor has combined ac and dc approaches to increase the integration of display controllers for PC monitors, obtaining lower cost through fewer components and more efficient design.
Andrew Morrish
- 32 Bringing the NEC 20-in. LCD to Military Customers**
Skepticism about using COTS glass in military displays and mysterious flickering in a key Navy application were two hurdles that had to be overcome before customized commercial LCDs became accepted in critical military applications.
Mike Forde
- 38 By the Queen's Way**
The 31st annual SID International Symposium will draw display professionals from around the world to its largest exhibition ever, technical sessions, seminars, special events, and the Display Technology Showcase – all within sight of the magnificent HMS Queen Mary.
Ken Werner
- 50 Calendar of Display-Related Events**
- 54 SID 2000 Hotel Information**
- 56 Index to Advertisers**
- 56 Sustaining Members**

Looking Forward



All analysts agree that the current cyclical TFT-LCD shortage will eventually end, to be replaced by a cyclical surplus. Manufacturers hope the surplus will be less devastating than the last one (1998), while PC and monitor makers may have a different perspective.

Last year, Stanford Resources published its annual multi-client report *Liquid-Crystal Displays - 1999* and, jointly with Techno Systems Research of Japan,

the quarterly *Global LCD Supply/Demand Quarterly*. Data from these reports that addressed projections of supply and demand were used in the article "AMLCD Markets Diversify" by Joe Castellano, published in the January issue of *ID*.

The latest reports addressing these issues are from International Data Corporation (IDC) and DisplaySearch. Published last October, IDC's report projects serious shortages of display driver ICs, color filters, polarizing filters, and capacitors and resistors through 2000, with motherglass demand outstripping supply through 2001.

DisplaySearch forecasts that a surplus will begin in Q4 '00. DisplaySearch's Ross Young enriched the research data with a personal anecdote in an interview with *ID* last October.

I tried to buy a new notebook last month because mine was falling apart. I got on the Dell Web site, ordered it, and got a confirmation e-mail from their sales staff saying it would be delivered in seven weeks. I called and told them I needed it sooner and would accept a different model/configuration, etc., but they told me it was seven weeks for all configurations due to the display shortage.

This was before the glass shortage became severe. Some supply is loosening in the LCD-monitor market because prices have risen too high to sustain demand, but the shortage continues in notebooks.

Based on glass-capacity data provided by Japanese market-research firm ADR, market demand is greater than glass capacity by 138,000 m² per month in Q4 '99. At the same time, TFT-LCD capacity is 73,000 m² per month less than market demand. We expect the glass-shortage problem to linger until Q4 '00. There are only four glass suppliers, and they, like the rest of the industry, did not invest in 1998 and have struggled to keep up with the dramatic growth in TFT-LCD demand in 1999. Although TFT-LCD producers have boosted capacity by simplifying their production processes from 6 to 5 to 4 masks, have minimized downtime for cleaning, and have overcome bottlenecks, the glass-production process has not become more efficient. In fact, glass yields have worsened for some manufacturers in 1999 as they try to produce a lower-density substrate.

Just a few days before the end of 1999, Ross supplied his latest supply-and-demand data, along with the following comments:

We have compiled the following smoothed forecast of undersupply as a percentage of demand for the next few quarters based on our survey of worldwide LCD-monitor shipments on a quarterly basis and notebook-PC producers each quarter, and our forecasts of fab activity that we implement by

continued on page 50

Information DISPLAY

Editor: Kenneth I. Werner

Managing Editor: Jay Morreale

Administrative Editor: Dian Mecca

Administrative Assistant: Ralph Nadell

Contributing Editors: Aris Silzars,

Bryan Norris, Chuck McLaughlin,

Joe Hallett, Alfred Poor

Advertising Manager: Jay Morreale

Sales Manager: Tracy Leibowitz

Regional Associate Editors

Allan Kmetz (**Americas**)

Lucent Technologies

Liberty Corner, New Jersey

Shigeo Mikoshiba (**Asia**)

University of Electro-Communications

Tokyo, Japan

Alan Mosley (**Europe**)

Central Research Laboratories

Hayes, Middlesex, U.K.

Advisory Editors

Carl Machover

Machover Associates

White Plains, New York

Alan Sobel

Consultant

Evanston, Illinois

Webster E. Howard

FED Corp.

Hopewell Junction, New York

Ernst Lueder

University of Stuttgart

Stuttgart Germany

Sungkyoo Lim

Information Display Research Center.

Choongnam, Korea

The opinions expressed in editorials, columns, and feature articles do not necessarily reflect the opinions of the editor or publisher of *Information Display Magazine*, nor do they necessarily reflect the position of the Society for Information Display.

The Evolution of Powerful Video Generators Continues!

The Most Flexible Digital Video Generator

ASTRO VG-827

Service, repair, engineer or evaluate FPD's? This model is small, light and offers LVDS, TMDS (Panel Link) and parallel (24 or 48 bits/pixel) outputs. Also supports analog output up to 150 MHz dot clock.

- ▼ Original Digital with additional analog output
- ▼ 75 MHz/150 MHz Dot Clock
- ▼ 8 bits/pixel/color
- ▼ Operated/Programmed from PC or Remote Frontpanel
- ▼ ASTRO VG-826A offers digital outputs only

Standalone Digital units from \$4000



DIGITAL . STANDALONE . DIGITAL . STANDALONE . DIGITAL . STANDALONE

A New Generation in PC-Based Digital Video Generators

UNI VTG-1108pc

First again! This time with the first PC-Based Video Generator for Digital FPD's. Proven WINDOWS-based Software Package and Personality Modules to adapt to LVDS, TMDS (Panel Link) and parallel interface.

- ▼ 90 MHz/180 MHz dot clock
- ▼ Full DDC-compatibility
- ▼ ISA-Bus/16 or 32 bit DLL's
- ▼ Support for bitmap formats
- ▼ Parallel (24 or 48 bits/pixel) outputs
- ▼ Personality Module supports highest flexibility

PC-Based Digital units from \$5,500

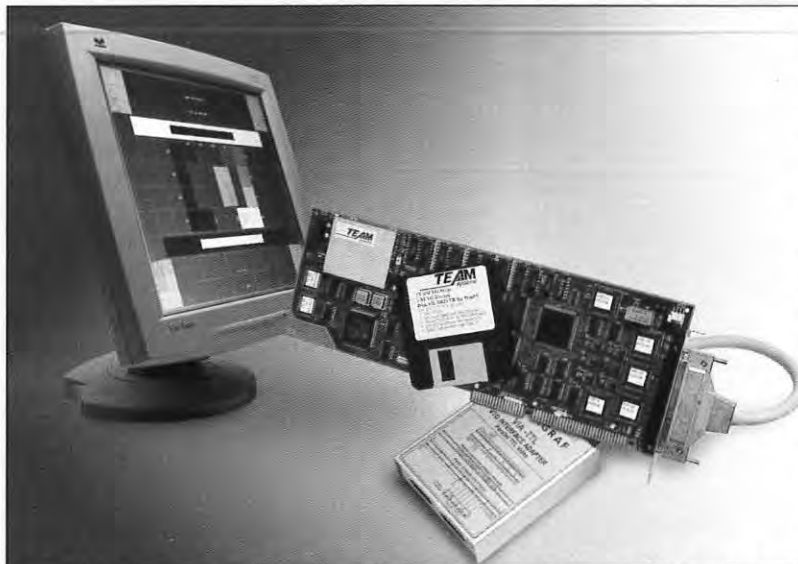

DIGITAL . PC-BASED . DIGITAL . PC-BASED . DIGITAL . PC-BASED . DIGITAL

Contact us today!

www.team-systems.com

1-800-338-1981

info@team-systems.com

Team Systems... The Smart Choice!

See Us at SID '00 Booth 221

Circle no. 5

TEAM
systems

"Digital Video Generators"



Ah, Now I Understand ...

by Aris Silzars

Some time ago, I was invited for a meeting with a high-level personage in a large corporation. This company still maintained its longstanding culture of rewarding upper-level executives with plush offices in the top two floors of a high-rise building.

Upon exiting the security-controlled elevator that had whisked me up to the next-to-highest floor, I could instantly feel myself sinking into the deep-pile carpeting. The environment was hushed silence, with only two secretaries occupying the overly spacious reception area. After the proper notification of my arrival, I was ushered into an equally spacious office with floor-to-ceiling windows overlooking a broad expanse of a major downtown metropolitan area.

This is not a "real" office, I thought to myself. Surely this must be a movie set for a stereotypical Hollywood film production. But, no, this was as real as my senses would allow me to believe.

One half of the office was arranged for meetings such as we were about to have, with a comfortable sofa and two plushy chairs - one of which was clearly intended for my "big choo-choo" executive host. How did I know? Well, when you find yourself in this kind of situation, you just know! Across from this friendly meeting area was the more formal desk with two less comfortable chairs for visitors, or lower-level managers, who may not be entertained quite as graciously. The desk itself was large enough so that reaching to the far corners while sitting behind it would be a serious challenge.

I couldn't help but try to imagine how I would feel having such an office as my work environment. It all seemed too perfect and too isolated from the activities of the world as I know it. Something else that I observed and found hard to understand was that this massive desktop had only one small in/out box in the corner nearest the door, one telephone, a pen set, and a perfectly clean embossed-leather desk pad in front of the executive. The in/out box contained just a few items on each of its two small mahogany shelves. On the credenza behind the desk sat a typical PC with a 17-in. monitor, and on the opposite end a small family photo. The monitor screen was open to the company's e-mail. And that was all! The desktop and credenza were otherwise incredibly bare.

How did this high-level executive manage to get anything done? On my desk, which is also of reasonably ample dimensions, seldom do I get a glimpse of even a small area of the wood-grained top surface. Of course, the reason is that arrayed on it are the latest phone messages, the incoming faxes and e-mails requiring immediate response, the lists of active clients, the technical articles that must be read as soon as possible, copies of patents, purchase orders, wafer carriers containing material that must be scheduled for testing, electron-gun parts, and drawings for the latest new display concept. The two shelves to my left contain information folders on other clients. Travel schedules and expense reports typically spill onto the floor in the corner bounded by the credenza and the bookshelves.

Now, I must tell you that I don't consider myself a messy person. In fact, I have been told that I am sometimes too neat and tidy. So what is my problem? Why don't I seem to be able to keep my desk as neat as the one I encountered on my visit?

continued on page 46

SID Executive Committee

President: A. C. Lowe
President Elect: A. Silzars
Regional VP, Americas: R. Donofrio
Regional VP, Asia: A. Iwamoto
Regional VP, Europe: B. Needham
Treasurer: A. R. Kmetz
Secretary: R. L. Wisnieff
Past President: W. E. Howard

Directors

Bay Area: J. Larimer
Beijing: S. Ding
Belarus: A. Smimov
Canada: T. Schmidt
Delaware Valley: J. W. Parker III
France: F. Maurice
Greater Dayton: R. Holmes
Hong Kong: C. C. Chang
Japan: S. Mikoshiba
Korea: M. Oh
Los Angeles: P. Baron
Metropolitan Detroit: V. Cannella
Mid-Atlantic: D. Ketchum
Mid-Europe: D. Theis
Minneapolis/St. Paul: V. Born
New England: W. Hamilton
Pacific Northwest: J. Rupp
Russia: M. Tomilin
San Diego: R. Ruff
Southwest: R. Seery
Taipei: F. C. Luo
Texas: Z. Yaniv
U.K. & Ireland: A. Mosley
Ukraine: V. Nazarenko

Committee Chairs

Academic: C. J. Summers
Archives/Historian: D. Dumont
Bylaws: C. Infante
Chapter Formation: H. Uchiike
Communications: J. Rupp
Convention: P. M. Heyman
Definitions & Standards: R. Miller
Honors & Awards: A. I. Lakatos
Long-Range Planning: A. Lowe
Membership: J. W. Parker
Nominations: W. E. Howard
Publications: A. Silzars

Chapter Chairs

Bay Area: N. Balram
Beijing: H. C. Hu
Belarus: E. Kaloshkin
Canada: A. Kitai
Delaware Valley: L. Bryner
France: R. Meyer
Greater Dayton: J. Byrd
Hong Kong: H. S. Kwok
Japan: M. Maeda
Korea: M. Han
Los Angeles: M. Kesselman
Metropolitan Detroit: S. Pala
Mid-Atlantic: A. Ghosh
Mid-Europe: D. Theis
Minneapolis/St. Paul: H. Holec
New England: S. Atwood
Pacific Northwest: T. Yuzuriha
Russia: S. Darevsky
San Diego: A. Wilson
Southwest: J. O'Donnell
Taipei: H.-P. D. Shieh
Texas: R. Fink
U.K. & Ireland: C. Williams
Ukraine: V. Sorokin

Office Administration

Executive Director: Dee Dumont
Executive Assistant: Jenny Needham

Society for Information Display

31 East Julian Street
San Jose, CA 95112
408/977-1013, fax -1531
e-mail: office@sid.org
http://www.sid.org

ZC&R precision coatings... On display everywhere.

From Air Force One on down, manufacturers of display products trust us for the finest optical coatings available. Our wide range of custom designed display coatings make a visible difference, and they know it.

ZC&R's advanced transparent conductive ITO thin-films meet the precise sheet resistance control required by today's state-of-the-art displays. And we've created a whole new set of accurate, index-matched ITO coatings to reduce internal reflections in the display system.

Whether it's Durable AR or Broadband AR coatings, Edge Filters, or specialized Night Vision Filters, we can improve your image. From prototype to OEM volumes, our filters are available on glass plates up to 24" in diameter and can be customized to meet your requirements.

So go ahead, contact us for your next quote. ZC&R. We're at our best when we're on display.



- Durable / Broadband AR
- ITO and IM-ITO
- Night Vision / Surveillance
- Band Pass Color Filters
- Beamsplitters
- Heat and Color Coatings
- Hot and Cold Mirrors
- High Power Laser
- Metal Coatings
- Thin Film Polarizers
- Fluorescence Filters
- NVIS Filters

- *Ion-assisted technology*
- *Up to 24" diameter*
- *Prototype to OEM volumes*
- *Fast delivery*
- *MIL-C-675, MIL-C-48497 & MIL-M-13508 qualified*

ZC&R
COATINGS FOR OPTICS

1401 Abalone Ave.
Torrance, CA 90501
310-381-3060 / 800-426-2864
Fax: 310-782-9951

Circle no. 6

info@zcrcoatings.com / www.zcrcoatings.com

See Us at SID '00 Booth 760



CRT *Solutions*

from  **ist**

IST and IST-CRT Scientific have Consolidated!

With our manufacturing and technical resources now combined in a new custom-built facility, you can expect even greater commitment to exceeding your needs in a constantly changing and ever more demanding industry.

From our new location, the CRT Group at IST is pleased to offer CRT services for the following applications:

- **Avionic Cockpit Displays**
- **Military Track Vehicle FLIR Displays**
- **Helmet-Mounted Displays**
- **Light-Valve Projection Displays**
- **Medical / Direct View Monitors**
- **Color Film Recorders**
- **GPS Displays**
- **Field Sequential Color Displays**
- **Microfilm Data Storage**
- **Printing / Publishing**
- **Radar Displays**
- **Flying Spot Scanners**
- **CRT Lamination**
- **Phosphor Coating**

Contact the CRT Group at IST Today!



Imaging and Sensing Technology Corporation

500 IST Center
Airport Corporate Park
Horseheads, NY 14845 USA
Tel: 800-836-2033
E-mail: CRTinfo@istcorp.com

<http://www.istcorp.com>



Your Lifeline To The Digital Age Has Just Arrived. Introducing The MicroCross™ DVI.



High-res digital and analog displays are here. And so is *Digital Visual Interface (DVI)*. It's the integrated, cost-effective interface that's your shortcut to the future of digital display technology. What ties it all together? The MicroCross™ DVI interconnect system from Molex.

The Digital Display Working Group (DDWG)* chose the innovative MicroCross DVI system because it offers impressive bandwidth** in a small, rugged package with excellent EMI shielding. MicroCross DVI also takes advantage of new plug and play extensions and it supports digital and analog display technology, plus provides hot-plugging capabilities.

Best of all, everything you need is available from one reliable source — Molex. We offer both digital and digital/analog versions, including cable assemblies, right angle and vertical receptacles and adapters.

So why just tread water when we're offering you a lifeline? To find out how MicroCross DVI can help you save PCB real estate and provide the ultimate video solution, contact Molex today.

Americas Headquarters
Lisle, Illinois 60532 U.S.A.
Tel: 1-800-78MOLEX
Fax: 630-969-1352

Far East North Headquarters
Yamato, Japan
Tel: 81-462-65-2324
Fax: 81-462-65-2361

Far East South Headquarters
Jurong, Singapore
Tel: 65-262-6868
Fax: 65-265-6044

European Headquarters
Munich, Germany
Tel: 49-89-413092-0
Fax: 49-89-401527

Corporate Headquarters
2222 Wellington Court
Lisle, Illinois 60532 U.S.A.
Tel: 630-969-4550
Fax: 630-969-1352

© 1999, Molex

*DDWG promoters are: Intel Corporation, Silicon Image Inc., Compaq Computer Corporation, Fujitsu Limited, Hewlett-Packard Company, International Business Machines Corporation, NEC Corporation

**9.9Gb/s over digital dual link implementation and 2.5 GHz analog.



Bringing People & Technology
Together, WorldwideSM

Visit our Web site at <http://www.molex.com/ads/DVI.htm>

See Us at SID '00 Booth 849

Circle no. 8

Flat Panel Monitor **ARMS**TM

Call: 1.800.888.8458

Ergonomically position your flat panel monitors, laptops and keyboards wherever you need them—with Ergotron's **Adjustable Rotating Mounting Solutions**

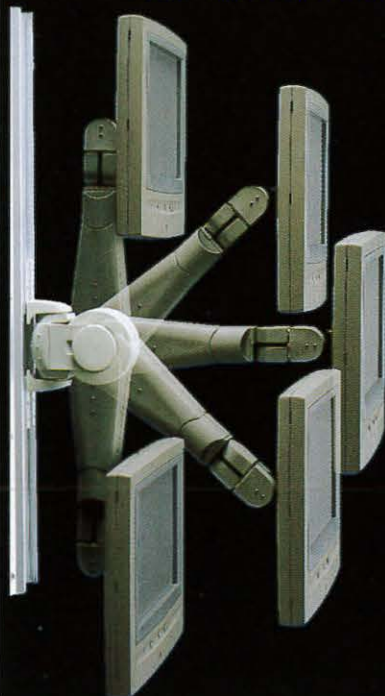

Mobile Solutions



Wall Mount Solutions

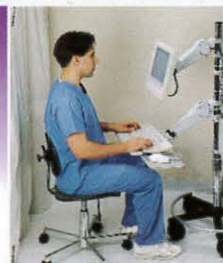

Custom Mount Solutions



Laptop Mounting Solutions



ERGOTRON[®]

1.800.888.8458 <http://www.ergotron.com>

See Us at SID '00 Booth 253

Circle no. 9

Lesker

OLED

LOW TEMPERATURE
Evaporator

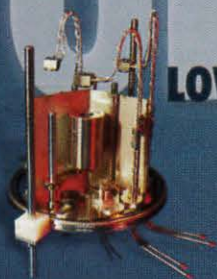

"...vacuum science is our business"



FEATURES AND BENEFITS:

- Unique design for use with low temperature volatile organics
- Operates at low temperatures with superior thermal control in 50°C - 600°C range
- Performance: Ability to grow 5% uniformity films on 6" substrates at greater than 5Å/sec
- Ideal for use in tandem for co-deposition of dye-doped organic emissive films

LOW TEMPERATURE POWER CONTROLLER IIP FEATURES & BENEFITS:

- Multiple stored programs for multiple organic materials and vacuum preparation routines
- Can control up to 4 Evaporators, sequentially
- Auto tuning modes and no temperature overshoot
- RS232 Communications
- CE marked version available

United States
Phone: 1.800.245.1656
Fax: 412.233.4275

Canada
1.800.465.2476
416.588.2602

United Kingdom
+44 1424 719101
+44 1424 421160

Germany
(0130) 812 843
(0130) 812 842

Hungary
+361 383 5322
+361 383 4369

Kurt J. Lesker
Company
www.lesker.com 412.233.4200

See Us at SID '00 Booth 937

Circle no. 10



WHICH TOOL IN YOUR FAB IS THE WEAK LINK?

Excess static charge in just one tool can start a chain reaction that ends in product damage and downtime. That's why the leading experts in electrostatics introduced SEMI E78, also known as The Static Budget Guide for Capital Equipment, through the SEMI® International Standards Program.

It's simple. E78-compliance enables faster ramp-up of new tools and processes by improving OEE and uptime.

Now you can prevent static-induced problems where they start: at the tool. E78-compliant tools are your link to greater productivity. Contact Ion's Professional Services for more information and a free set of sample static control requirements for your equipment purchase specifications at 800-367-2452 or www.ion.com/E78.html.

ION
THE ELECTROSTATICS
MANAGEMENT EXPERTS

See Us at SID '00 Booth 508

800.367.2452

510.548.3640

www.ion.com

Circle no. 11



ION SYSTEMS

Check what you need in your display analysis system:

- ✓ flat panel tests
- ✓ CRT tests
- ✓ easy upgrades (hardware and software)
- ✓ standard for ISO, NIDL, and VESA testing
- ✓ optimized for fast, accurate, and automatic testing with many packaged test suites

If you checked all of the above,
you have chosen the Microvision SS200 Family
of Display Analysis Systems

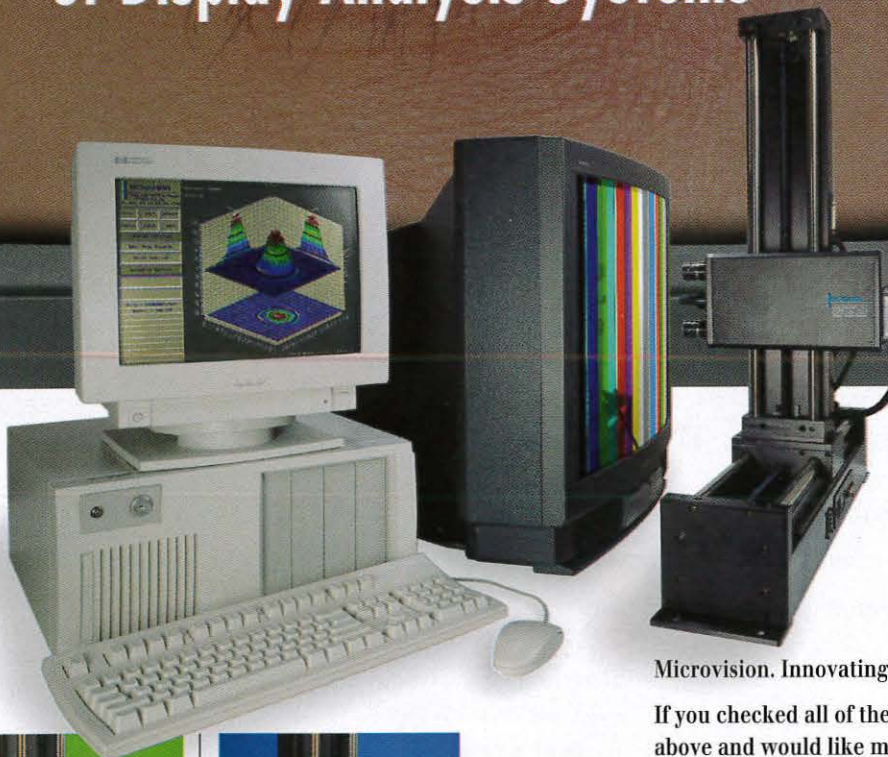

With the SS200 family, you can precisely, automatically, and completely measure display performance—and that includes flat panels.



SS200

Complete turnkey system with computer, 6-axis positioner, monitor, software, and SS200 camera system. Automatically performs spatial and luminance measurements.



SS210

You can easily field upgrade to the more powerful SS210 package, which provides all SS200 functions, plus an integrated spectrometer for spectral analysis and color measurements. Includes response time measurement capability.



SS220

For flat panel testing, a field upgrade to the SS220 is easy. The SS220 provides spectrometer-based off-axis measurement, color analysis, color shift and luminance testing. Coupled with the SS210, this is the most comprehensive test system ever offered—at a fraction of the cost of individual test instruments. All tests are performed at NIST-traceable accuracy.

Microvision. Innovating since 1985.

If you checked all of the above and would like more information, call Microvision at (800) 951-5188.

MICROVISION

Dedicated to the Needs of the Display Industry

550 High St., Suite 108 / Auburn, CA 95603
Tel: (530) 888-8344 / Fax: (530) 888-8349
Toll Free: 1 (800) 931-3188
Email: microvsn.com
Web site: <http://www.microvsn.com>

International Reps:
Japan - ARGO CORP., 06 559 5566
Taiwan - SUPERLINK TECH., 02 705 7090
Korea - B & P INT'L, 02 546 1457

See Us at SID '00 Booth 215

Circle no. 12

Make a Battery this Big , Last Like a Battery This Big



KENT ChLCD™ No Power Displays

DESIGNED FOR PORTABLE EQUIPMENT

Unlike conventional LCD units, Kent ChLCD (Cholesteric Liquid Crystal Display) use power only to generate images – not to update, or refresh images. In fact, ChLCD images can be displayed indefinitely – seconds, hours, weeks or even years – without consuming a millijoule of power. It makes these displays ideal for any type of portable equipment where increasing battery life is important.

EASIEST TO READ REFLECTIVE DISPLAY TECHNOLOGY

ChLCD displays also offer better viewing than conventional LCD displays – especially in direct sunlight. With a 360 degree viewing cone and very high contrast, ChLCD displays offer exceptional reflectivity, without back lighting.

GET THE FACTS

To learn more about this technology that enables you to do more, call us at **330-673-8784** or visit our website at www.kentdisplays.com/pd.

Circle no. 13



KENT DISPLAYS
INCORPORATED

A MANNING VENTURES BUSINESS UNIT

Kent Displays, Inc. • 343 Portage Boulevard • Kent, OH 44240 • Phone: 330.673.8784 • Fax: 330.673.4408
Internet: <http://www.kentdisplays.com> • E-mail: sales@kentdisplays.com

Products and technologies of Kent Displays, Inc. are protected by the following patents: United States: 5,437,811; 5,381,067; 5,251,048
People's Republic of China: 92103952.2; Israel: 101,766; Taiwan: 90140561; PCT (EP, Canada, Korea, Japan and Norway): 9203598; 9209367. Other Patents Pending.

See Us at SID '00 Booth 633

1/4 VGA "No Power" Display Modules



Kent Displays' 1/4 VGA ChLCD "No Power" design not only provides exceptional readability but also requires no power to maintain displayed images, only to change them. Because power isn't constantly used to retain the image, expect exceptionally long battery life. Ideally suited for portable battery-operated products, this unit is excellent for displays that must be readable at any angle, even in direct sunlight.

The 1/4 VGA format is ideal for portable communication devices, data collection products, global positioning systems and more. Available with or without an on-board controller, in 4 color combinations: yellow/black, yellow-green/black, green/black or blue/white. This display features an imaging area of 4.48 in. by 3.36 in. with a pixel resolution of 72 dots per inch.

KENT Displays, Inc., 330-673-8784

E-mail: sales@kentdisplays.com

Circle no. 14

1/8 VGA "No Power" Display Modules



KENT 1/8 VGA display modules feature ChLCD technology for no power consumption except for image generation. This technology also provides high contrast and a wide viewing angle. They are available with a standard resolution of 100 dpi and an active viewing area of 40.6 mm by 61.0 mm (1.60 in. by 2.40 in). They're ideal for applications such as portable communications, data collection, global positioning systems and more.

KENT Displays, Inc., 330-673-8784

E-mail: sales@kentdisplays.com

Circle no. 15

The Future of Organic Light-Emitting Diodes

OLEDs have become the hot new display technology, with many players establishing their positions - but there is still a long way to go before the technology fulfills its potential.

by Nigel Bailey

SOME display-industry watchers have developed high expectations that organic light-emitting diodes (OLEDs) will provide a real route toward realizing the long-held vision of paperlike displays. Although this promise has been evident for several years - at least since 1983 - OLED products are only now beginning to enter the smallest of the many display markets they may eventually penetrate.

What are the major types of OLEDs, who are the major players in the technology, and what are the obstacles that are currently denying OLEDs the mass-market status that they deserve?

Simple Design, Numerous Advantages

OLEDs promise to deliver thin, lightweight displays with low power consumption, wide viewing angle, and sub-microsecond switching. In the long term, they also promise to be cheap.

The basic OLED architecture consists of a number of ultra-thin layers on a transparent substrate (Fig. 1). Onto the substrate are deposited a transparent electrode, usually the anode; an emissive organic layer, often accompanied by one or more charge-transporting organic layers; and a back electrode. The combined thickness of these active layers is less than $1 \mu\text{m}$, which distinguishes OLED technology from thin-film inorganic electro-

luminescence (TFEL) technology, in which the active layers are usually several microns thick. Because OLEDs are so thin, a voltage of only 5-10 V applied between the electrodes causes an electric field high enough to inject charges into the organic layers. In an optimized device, recombination of these charges in the emissive layer produces the light output, which is viewable through the transparent electrode.

OLED technology offers a number of improvements over the LCD technology currently used in many of its potential markets:

- OLEDs are emissive devices, so OLED displays generate their own light and do

not require backlighting. This can reduce the power consumption and bulk of the assembled display module, and also makes the display viewable over a wide angle.

- OLEDs exhibit fast sub-microsecond switching times, which allows high-quality video content.
- OLED technology is compatible with many of the processing techniques suitable for plastic substrates, opening up two possibilities. First, displays could be made on lightweight, flexible, and robust substrates. Second, it may be possible to manufacture OLEDs by roll-to-roll pro-

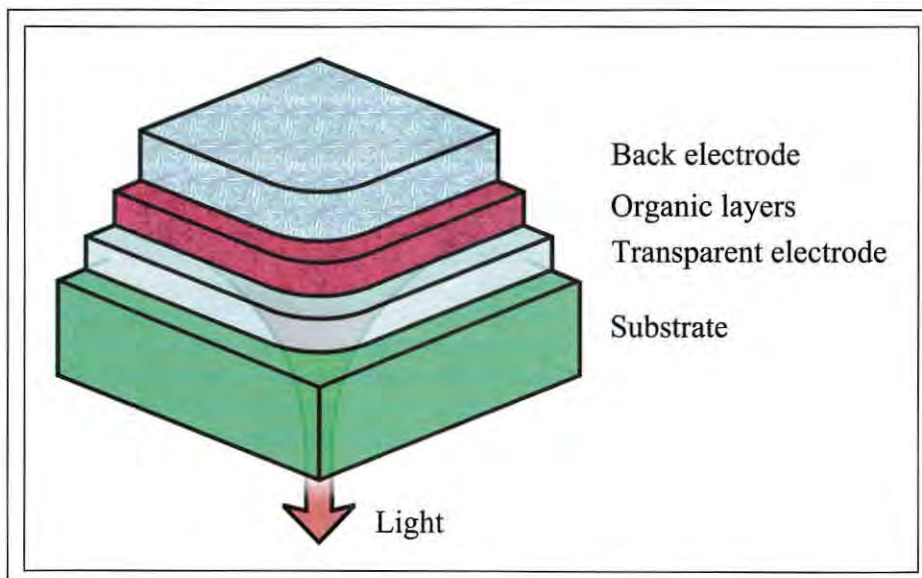

Fig. 1: The basic structure of an organic light-emitting diode consists of a number of ultrathin layers. The combined active layers add less than $1 \mu\text{m}$ to the thickness of the substrate.

Opsys Limited

Nigel Bailey is Business Development Manager at Opsys Limited, Unit 8, Begbroke Business & Science Park, Sandy Lane, Yarnton, Oxford, OX5 1PF U.K.; telephone +44-1865-309609, fax +44-1865-847444, e-mail: nigel@opsys.co.uk.



Pioneer

Fig. 2: Pioneer is currently producing multicolor organic electroluminescent displays for automotive audio products.

cessing techniques, achieving (in the long term) substantial economies over existing flat-panel-display manufacturing processes.

- OLEDs have a conceptually simple design and are fabricated from inexpensive materials.

There are a number of technologies vying for success in the OLED arena. The easiest way to categorize the companies competing to develop OLEDs is by their principal affiliation to one or another of the light-emitting materials technologies that will now be described.

Small-Molecule OLEDs

In small-molecule [sometimes called "low-molecular-mass" (LMM)] OLEDs, the light emitters are discrete molecules (as opposed to polymers, which are long chains of "molecules" strung together). The first OLEDs in this category contained aluminum quinolate (Alq_3) and were developed by Ching Wan Tang and Steven Van Slyke at Eastman Kodak Company in 1987. Alq_3 produces a broad green emission covering the wavelength range from 450 nm to over 700 nm and peaking at 550 nm. Other colors can be produced by inserting dopant molecules into the Alq_3 layer or by changing aluminum for a different atom, such as beryllium. Physical vapor deposition is the technique currently most suitable for deposition of the active layers in small-molecule OLEDs, although several companies are investigating alternatives, such as printing processes.

Kodak has embarked upon a global licensing program for its technology, which began with the 1998 non-exclusive license to Pioneer Electronic Corporation of Japan. The

Pioneer subsidiary Tohoku Pioneer is producing 64×256 -pixel multicolor OLED panels in volumes of 30,000 per month on a new \$28.2 million line installed at its Yonezawa plant (Fig. 2). Pioneer has also demonstrated (at SID '99) an impressive full-color 5.2-in.-diagonal quarter-VGA passive-matrix OLED display. The sub-pixel pitch in the display is 0.11 mm. This was achieved by sequential evaporation of the red, green, and blue light-emitting materials through a shadow mask by means of a highly accurate mask-moving system.

February 1999 brought Kodak its second major Japanese licensee, Sanyo Electric Co., Ltd. In September 1999, Kodak and Sanyo jointly announced the world's first active-matrix full-color OLED display – a 2.4-in.-diagonal display that contains 852×222 dots at a pitch of $0.057 \times 0.165 \text{ mm}^2$ and is driven at 12 V. The display results from the integration of Kodak's light-emitting-molecule and film-forming technologies and Sanyo's low-temperature-polysilicon (LTPS) TFT technology. They plan to start production in mid-2000 with passive-matrix multicolor displays and to move to full-color active-matrix displays by 2001.

Other developers that licensed Kodak's portfolio on small-molecule OLEDs include TDK Corp. in Japan and FED Corp. in the U.S., a privately held company based in Hopewell Junction, New York. The license granted to FED Corp. covers uses in microdisplay products including head-wearable displays, viewfinders, and some military applications. FED Corp. recently accelerated its development in the area of head-mounted displays by the acquisition of Virtual Vision, Inc. (Redmond, Washington), a company with expertise in headsets and integrated optics.

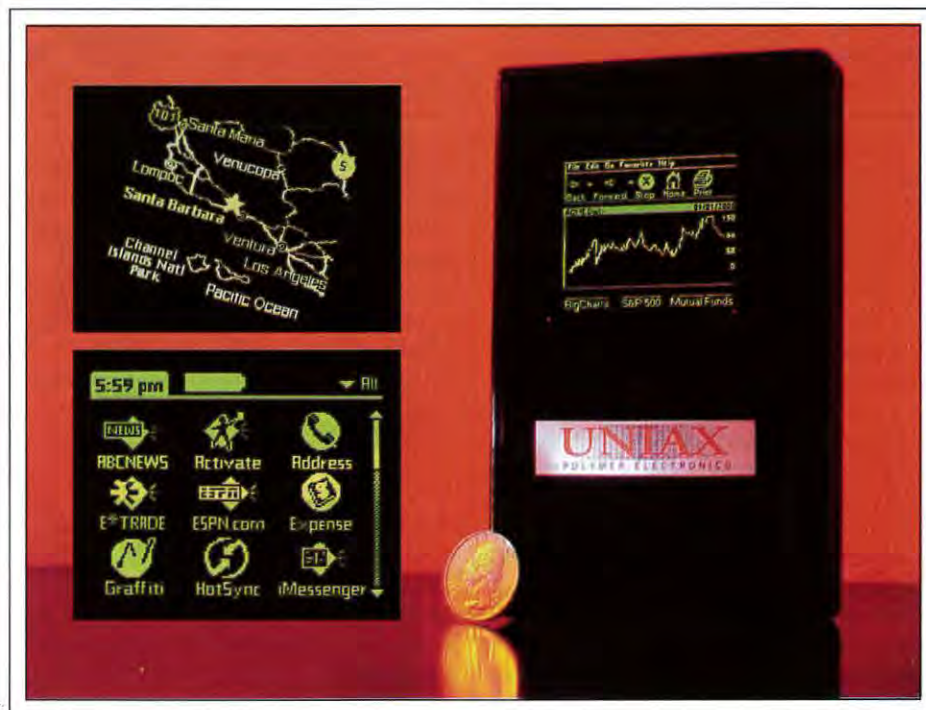

UNIAX Corp.

Fig. 3: UNIAX's PDA demonstrator contains 160×160 pixels.

LED technology



Covion Organic Semiconductors GmbH

Fig. 4: These OLEDs contain light-emitting materials manufactured by Covion Organic Semiconductors GmbH of Frankfurt, Germany.

At the Center for Photonics and Optoelectronic Materials at Princeton University and at the Department of Chemistry, University of Southern California, research into electrophosphorescent OLEDs has resulted in a small-molecule device with a peak power efficiency of 31 lm/W. This is the highest efficiency published to date for an OLED, to the best of this author's knowledge. The work is principally funded by Universal Display Corporation (UDC) in New Jersey, whose proprietary technology is centered around three platforms: TOLEDs, SOLEDs, and FOLEDs, representing transparent, stacked, and flexible OLEDs, respectively. The TOLED is enabled by UDC's transparent-cathode technology, which in turn enables the SOLED pixel architecture, a vertical stack of red, green, and blue TOLED pixels. Assuming that the patterning and addressing issues now being worked on will be satisfactorily resolved, SOLEDs will triple the resolution offered by conventionally patterned RGB sub-pixels. UDC has demonstrated flexible devices, and points out that plastic substrates could enable the low-cost roll-to-roll fabrication of OLEDs.

UDC recently licensed its TOLED technology to Luxell Technologies, Inc., a TFEL FPD manufacturer based in Mississauga, Ontario, Canada. Luxell's interest in OLEDs derives primarily from its proprietary high-contrast black optical-interference layer, which it claims will allow significant reductions in operating luminance, with consequent improvements in operating lifetime and power consumption.

Luxell is not the only TFEL manufacturer to develop an interest in OLEDs. Lite Array – a California corporation that formed a 50-50 joint venture with a company in Jiangmen, China, in 1994 – believes it has overcome the high-cost barrier to TFEL display manufacturing that has been limiting TFEL to niche markets. At its research and development center in Novato, California, Lite Array is also looking into small-molecule OLEDs. They have demonstrated over 10 lm/W for Alq₃-based systems. TFEL manufacturer Planar is also investigating opportunities in the OLED field.

Light-Emitting Polymers

Organic polymers consist of long chains of

sub-units called monomers. The processing properties of polymers are well known as a result of their extensive use in the plastics and petrochemical industries. Champions of light-emitting-polymer technology cite large-area patternability with solution processing techniques such as ink-jet printing as one of its attractive features.

Electroluminescence from polymers was first observed in 1989, when Richard Friend and Andrew Holmes at Cambridge University's Cavendish Laboratory discovered that the polymer polyphenylenevinylene (PPV) could be used in place of traditional semiconducting materials in LEDs. Cambridge Display Technology (CDT) was founded in 1992 to exploit a key patent covering light emission from conjugated polymers. Since then, CDT has broadened the scope of its development from PPV to new types of light-emitting polymers, growing to over 55 employees and opening up joint-development, licensing, and technology-transfer relationships with a number of partners.

The first of these to bring a product to market is likely to be Philips Components, whose "PolyLED" business group is based in Heerlen, The Netherlands. The group's pilot plant has the capacity to produce 10 million cm² of devices per year. Philips plans to produce backlights initially, but has also demonstrated a prototype display consisting of 87 rows and 80 columns that is capable of 256 gray levels.

A close collaborator of Philips has been UNIAX Corporation of Santa Barbara, California, founded in February 1990 to develop its conducting-polymer technology pioneered by Alan Heeger and licensed from the University of California at Santa Barbara. It currently employs about 30 people and sees its initial product opportunity as a small dot-matrix display for mobile applications. The UNIAX team has developed a manufacturing process it claims is ready for scale-up to commercial production. The UNIAX pilot production facilities have the capacity to fabricate up to 4000 2-in. passively addressed polymer displays per month. The panels feature a yellow-green monochrome 64 × 96-pixel array and a multicolor icon area. UNIAX has also recently shown a demonstrator personal digital assistant (PDA) display in 160 × 160 format (Fig. 3).

Hoechst of Germany was an early entrant into light-emitting-polymer development

through its subsidiary, Aventis Research and Technologies. A joint venture between Aventis and Avecia Limited (formerly Zeneca Specialties) named Covion Organic Semiconductors GmbH of Frankfurt, Germany, was created in early 1999. Covion aims to become the leading supplier of organic semiconductor materials to the OLED industry. Their product portfolio includes soluble derivatives of PPV with various emission colors (Fig. 4), and new spiro-bifluorene small molecules that have similar electronic properties to existing materials but improved temperature stability.

Philips, UNIAX, and Covion are all licensees of CDT's basic patent. CDT has also licensed its technology to DuPont, Hewlett-Packard, and Seiko-Epson Corp. Little is known about the results of the DuPont and H-P relationships, but the Seiko-Epson collaboration, started in November 1996, has already produced a full-color active-matrix-addressed display fabricated by ink-jet printing. By pooling Seiko-Epson's expertise in LTPS and ink-jet printing with CDT's light-

emitting-polydiarylfuorene technology the team was able to demonstrate a proof-of-principle multicolor light-emitting-polymer display with fine patterning of RGB pixels. They coated a poly-Si TFT substrate with a polyimide layer that was then etched to produce a series of wells 30 μm in diameter placed at intervals of 70 μm (quite a low fill factor). The emitting materials were ink-jet printed into the wells and dried, and the top contacts were deposited by evaporation.

Rare-Earth (Lanthanide) OLEDs

Rare-earth light emitters present an alternative to the small-molecule and polymer technologies. The rare earths, also known as the lanthanides, are a group of 14 elements - cerium to lutetium - in the middle of the periodic table. The light-emitting molecules in rare-earth OLEDs consist of a metal core surrounded by an organic shell (Fig. 5). The mechanism of light emission is different from that of the Alq₃ and polymer systems. Excited states are formed on the organic shell and

energy is then passed to the metal core, which emits light with very pure color. (This fundamental behavior of rare earths has been used for many years to provide spectrally pure phosphors for CRTs.) Another advantage of rare-earth materials is that both singlet and triplet excited states can result in light emission. (Passing an electric current through an OLED causes two types of excited molecules: singlets and triplets, in the ratio 1:3. In most systems, including light-emitting organic polymers and Alq₃, only singlet states can emit light, capping the theoretical maximum power efficiency at 25%.)

Rare-earth materials in OLEDs have been investigated by Prof. Junji Kido of Yamagata University in Japan, and by Sanyo and Sony, and are now being developed by two start-up ventures in the U.K. Opsys Limited, an Oxford University spin-off founded in 1997 on the basis of research into rare-earth-based OLEDs by Dr. Victor Christou in the Department of Chemistry and Dr. Oleg Salata in the Department of Engineering Science, has now assembled an interdisciplinary team of 25 researchers working in the area. Opsys values close feedback between chemists and optoelectronic engineers as its important core capability. The company has demonstrated red, green, and blue OLEDs using its proprietary organolanthanide phosphor (OLP) materials, achieving 2.2 lm/W at 70 cd/m² and 10 V with its best material.

Competing in the same area, ELAM-T was founded in April 1999 to exploit rare-earth materials developed at South Bank University, U.K. ELAM-T asserts that it has demonstrated efficiencies in excess of 70 lm/W, which is comparable to a cold-cathode fluorescent tube.

Challenges to OLED Developers

Despite the huge advances seen in all kinds of OLEDs in the last few years, they remain an immature technology, and developers face many commercial and technical challenges.

The main commercial challenge will be to penetrate a supply chain currently dominated by LCD technology. The ease of doing this will vary from market segment to market segment, and will be hardest in high-value segments such as notebook computers, where the technical challenges are greatest, the LCD manufacturers exert the highest degree of control over the supply chain, and existing overcapacity will motivate LCD makers to compete tooth and claw on cost.

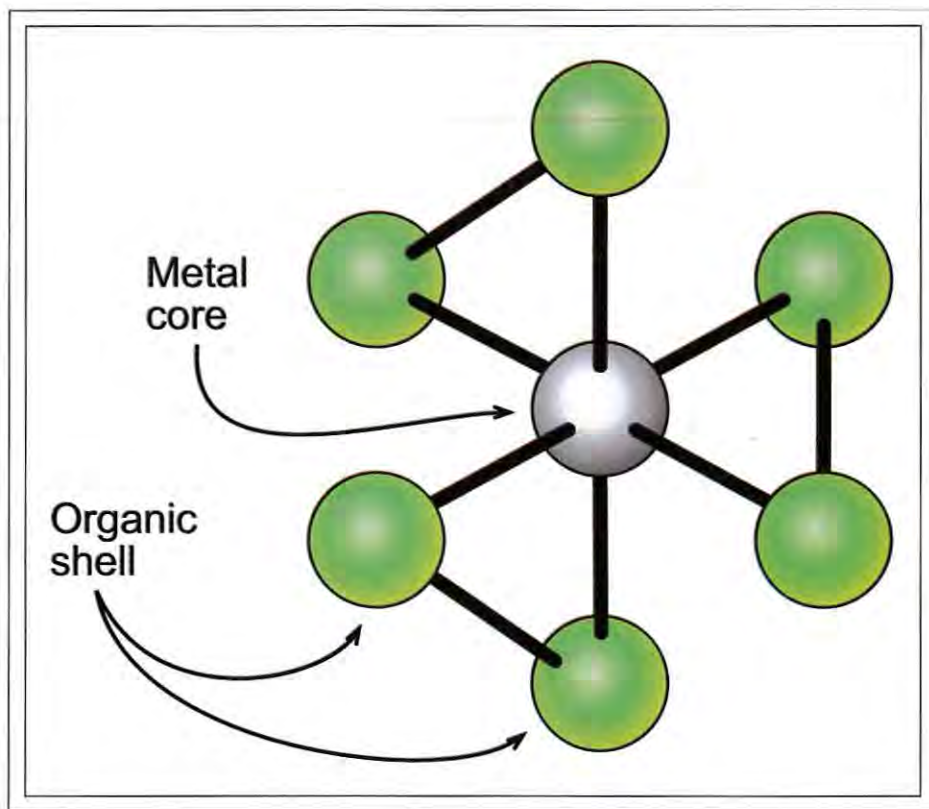

Opsys Limited

Fig. 5: An organolanthanide phosphor (OLP) consists of a lanthanide metal core surrounded by a "shell" of organic ligands.



Apogee-One

Apogee Touch/LCD System is the turn-key solution to your man-machine interface needs. Bright and crisp color-TFT integrated with digital resistive touch screens is the most reliable touch solution you could ever find.

It's that simple!
Get in touch with CyberTouch.



CyberTouch

Touch Screens • Touch Monitors • Touch Systems

805.499.5000 • Fax 805.499.5888

sales@cybertouchusa.com

www.cybertouchusa.com

LED technology

One of the obvious ways to reduce the cost of OLEDs is to move to continuous processes, such as roll-to-roll processing. Some companies are already active in this area. For example, PlastDisplay of Palo Alto, California, is developing technology relating to the fabrication of TFTs on plastic substrates for use in OLEDs.

Any move to high-volume manufacturing will require developers to address several challenging technical issues:

- **Device stability, both in storage and operation.** Differential aging of color pixels leads to poor color fidelity. Encapsulation solutions will need to be found, and barrier technologies will need to be developed for plastic substrates.
- **High-volume manufacturability.** As yet unproven, high-volume manufacturing would place strenuous demands on purity and deposition uniformity.
- **Patterning issues.** Full-color displays will require further improvements in patterning techniques for the emissive and cathode materials. Post-deposition patterning is difficult for OLED materials. Patterning during deposition is more promising.
- **Addressing issues.** Passive-matrix-addressed displays suffer from higher operating voltages, leading to reduced efficiency and heat-induced degradation. Large-area displays will require active-matrix addressing with at least two transistors per pixel, which will limit resolution and decrease manufacturing yield.
- **Optical problems.** Device geometries must be optimized to lessen optical effects such as internal reflection losses.

A Bright Future

For all these reasons, most display-industry analysts agree that in the near future OLEDs are likely to be limited to simple light-emitting surfaces for LCD backlights and some small monochrome and multicolor displays, where both the technical and market-entry challenges are more easily met. This process is already under way. Pioneer Electronics is already producing multicolor OLED displays for automotive audio products. We can also expect to see OLED displays appearing in specific segments of the handheld electronics markets, such as cellular phones, PDAs, digital cameras and camcorders, and certain niche applications such as head-mounted displays.

Stanford Resources expects the size of these OLED markets to exceed \$500 million by 2005.

As for the large-screen markets, customers will have to wait a little longer. But given the amount of talent working in the area, the number of research avenues that have opened up, and the rate of improvement in OLED performance observed in the last 3-4 years, it is likely that OLEDs will surmount the obstacles that separate them from mass markets, and at last fulfill the vision of large-area, thin, lightweight, and low-power displays. ■

Internet Consulting and Database Research

Get on the "Net." Training, lectures, Web sites, and consulting by the former Executive Director of the Internet Society. Visit the SID homepage at

<http://www.sid.org>

Database research. Patent Searches, Technical Literature, Competitive Analysis, Market Research, Demographics

H.L. Funk Consulting

7 Diane Court

Katonah, NY 10536

Telephone/Fax: 914-232-3530

E-mail:

consult@hlfunk.com

Circle no. 16

SID '00

Long Beach, California

Long Beach Convention Center

May 14-19, 2000



Order A Dozen Today.

Here's a fresh way to brighten up your office: computer images with realistic colors. Introducing Microfilter 99 CRT. By improving the red color filter and red phosphor in its Microfilter technology, Toshiba has extended the color range by 5%, resulting in brighter colors and glowing red hues that add dimension to its images. When combined with Toshiba's superior brightness and higher contrast, Microfilter 99 offers realistic colors that no other CRT can order up. Microfilter 99. Rose red, without the thorns.

microfilter^{CRT} 99™



In Touch with Tomorrow
TOSHIBA

<http://www.toshiba.com/taec>

Toshiba America Electronic Components, Inc., Electron Tube and Device Division: One Pkwy., North, Suite 500, Deerfield, IL60015 Tel:1-800-879-4963

See Us at SID '00 Booth 127

Circle no. 17

NOW YOU CAN GO ANALOG, DIGITAL, OR **BOTH** WAYS.

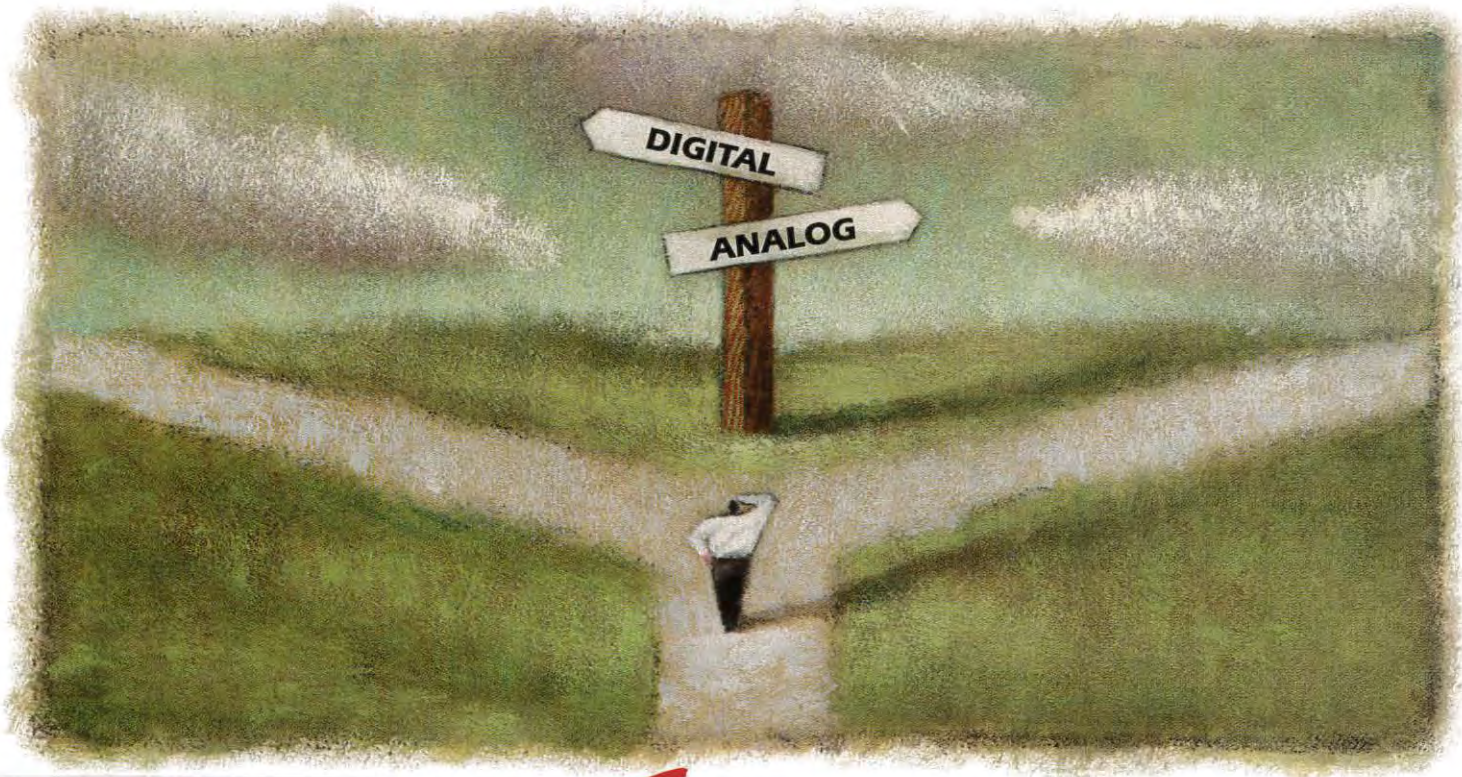

FAST VIDEO
DELIVERED YOUR WAY...
BENCHTOPS, PCI PLUG-INS, OR BUFFERS.



DVI VIDEO GENERATORS

330 MHz Digital
360 MHz Analog

LVDS VIDEO GENERATORS

400 MHz Digital
360 MHz Analog

DIGITAL DATA BUFFERS

330 MHz DVI



The Art of Technology

QUANTUMDATA

2111 Big Timber Road, Elgin, IL 60123
Phone: 847..888.0450 Fax: 847..888.2802
Website: <http://www.quantumdata.com>
E-mail: sales@quantumdata.com

See Us at SID '00 Booth 101

Circle no. 18



So easy on the eyes, it even makes your bottom line look better.

Pilkington **OptiTEC™** Anti-Reflective Glass.

The low-cost
solution to glare control for
CRT and flat panel display applications.

Now, there's an affordable, low-cost solution to glare control
for computer screens, televisions, flat screen and electronic displays,
and even glass display cases.



Pilkington **OptiTEC™** Anti-Reflective Glass.

With a pyrolytic anti-reflective coating that's actually bonded
to the surface of the glass while the glass is being made.

So not only is it more economical, but more durable as well,
for easier handling, fabricating, tempering, bending and more.

That means faster turn-around and lower costs, too.

And that's the bottom line.

For more information, visit us at www.pilkington.com/specialty or contact your
Pilkington representative.

Pilkington Libbey-Owens-Ford, Specialty Glass Products
P.O. Box 799, Toledo, OH 43697-0799
Tel: 419 247 4724; Fax: 419 247 4517

©1999 Pilkington Libbey-Owens-Ford. **OptiTEC™** Glass is a trademark of Pilkington.



PILKINGTON

Circle no. 19

The Flat Face of CRTs

Different manufacturers have adopted different approaches to making completely flat CRT screens, and consumers will be seeing a lot of them.

by A. A. S. Sluyterman

THE VERY FIRST color CRT with a flat screen was made by RCA – described in print in 1951 – when they were experimenting with color television. Flat-faced CRTs did not appear as products until some years ago, and only recently have they become widely available. In order to achieve significant long-term penetration of the market, the following boundary conditions have to be met:

1. The optical appearance of the tube, both in an activated and non-activated state, has to be good.
2. No significant loss must be discernible in picture performance aspects such as color purity, sharpness, and convergence.
3. The tubes must have acceptable mechanical rigidity.
4. The tube and its weight must be similar to equivalent tubes with spherical screens.
5. The cost increase must, in the long run, be minimal; otherwise, flat-faced CRTs will only appeal to a niche market.

From the above-cited requirements, it follows that the technology used must fit into current manufacturing processes. As it turns out, there are many ways to make a flat-faced CRT, but, in most cases, shadow-mask technology is the limiting factor for performance, and different approaches have been developed to tackle this problem.

A. A. S. Sluyterman is Senior CRT Architect at Philips Components, Building RAF-1, P.O. Box 218, 5600 MD Eindhoven, The Netherlands; telephone +31-40-278-2817, fax +31-40-278-6185, e-mail: seyno.sluyterman@philips.com

Two-Direction Tension Masks

In 1986, Zenith introduced a flat-faced color monitor tube that used a flat tension mask (FTM). They used a completely flat screen without a skirt. In order to avoid doming problems arising from the deformation of flat shadow masks, the mask was put under ten-

sion in two directions. In its final form – as it is currently used in LG's Flatron tubes – the mask was directly supported by a rail on the screen glass (Fig. 1). The resulting shadow mask resisted doming problems, making it possible to use high beam currents. To make use of this benefit, the tube had a low-trans-

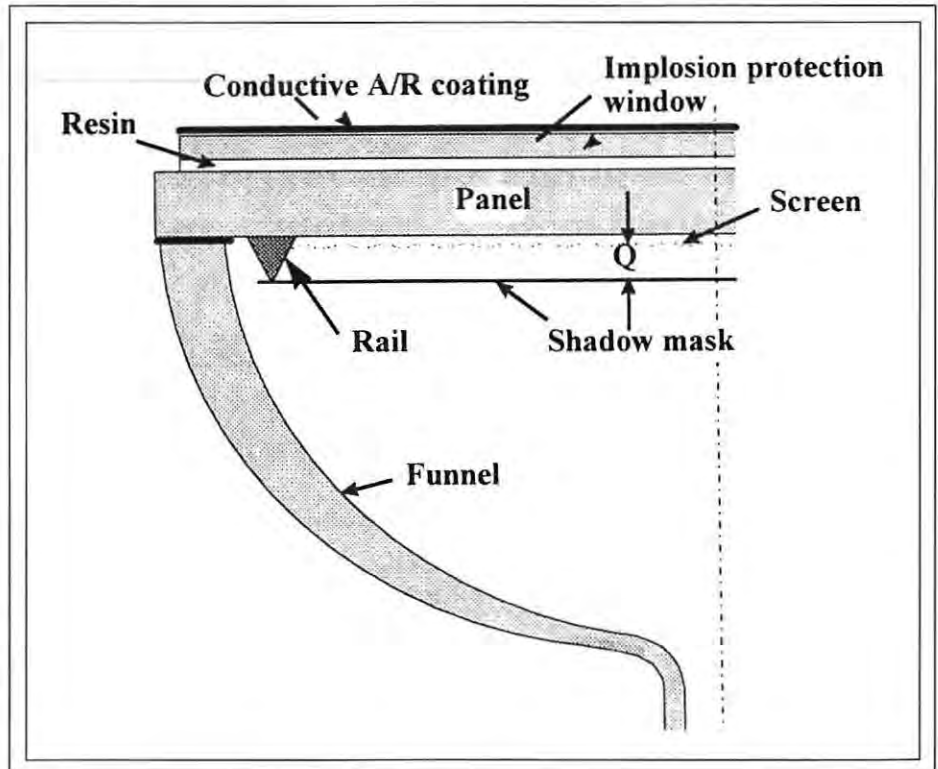

Fig. 1: The Zenith FTM tube design – now used by LG – uses a two-direction tension mask mounted on a rail.



Fig. 2: The aperture-grill tension mask can be adapted for use in flat-faced CRTs.

mission screen. The very high daylight contrast of the tube became one of its main selling features, even more than its flatness. In fact, the flat face possibly detracts from the display because the image appears to be slightly concave, or saucer-shaped. Another disadvantage of the tube is that the visible screen surface is relatively small because of the space taken up on the screen by the mask support ring.

For this design, the mask was put under tension after all screen processing had been completed. This meant that "non-married processing" was not only possible but required.

To minimize the changes in processing compared with a conventional tube, the two-direction tension mask could be mounted on a frame. Furthermore, a conventional - but flat - pressed screen could be used. This design was put forward by Hitachi in 1989 and has been used since 1996 by Matsushita in a 17-in. monitor tube called "Pure Flat."

One-Direction Tension Masks

Another mask design relies on tension in only one direction. This "aperture grille" approach is used by Sony for their TV and monitor tubes, and by Mitsubishi for their monitor tubes (Fig. 2).

Tubes with these aperture-grill masks have always been flat in the vertical direction. In 1997, Sony introduced "Real Flat" in a TV tube in which the screen was also flat in the horizontal direction, but only on the outside surface. Inside the face of the tube, the screen was slightly curved. The difference between the center screen thickness and the thickness of the screen in the corner is called "screen wedge." However, the mask is not only curved, but more curved than the inside of the screen (Fig. 3).

To accommodate this extra mask curvature, the stripe pitch along the sides of the screen is greater than the pitch in the center. This is called "grading" of the screen pitch, and works so long as the pitch remains invisible from a normal viewing distance. In the horizontal direction, the mask cannot be entirely flat because the damping wires that are necessary to suppress mechanical vibrations (microphony) of the mask become less effective as the horizontal curvature is reduced.

These tubes tend to be relatively heavy, and give the impression of a concave picture. This hollow impression is an optical effect caused by the rather large thickness of the screen glass, which is insufficiently compensated by the screen wedge. The lack of internal vertical screen curvature reduces the strength of the screen, which must be compensated by increasing its thickness, resulting in a heavier weight. The weight of the mask frame also must be high for aperture-grille tubes to maintain their tension over time.

To reduce frame weight, Matsushita has created a one-direction tension mask made of invar. Because of the lower expansion coefficient of invar, less tension is needed in the mask and, as a result, a lower frame weight is possible than for aperture-grille masks. Matsushita calls this their Semi-Stretched Tension (SST) mask, and currently uses it in all of their 4:3 aspect-ratio flat-faced television tubes.

Doubly Curved Masks

Most CRTs have a doubly curved shadow mask (Fig. 4), so it makes sense to find ways to make truly flat tubes while maintaining the doubly curved shadow-mask technology.

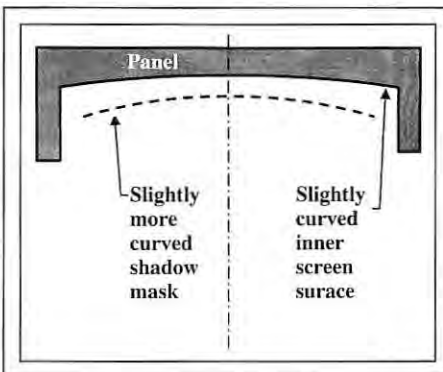

Fig. 3: This top view of the basic layout of the screen and mask of the Sony Real Flat tube shows how the mask is curved more than the screen.



Fig. 4: A doubly curved mask - similar to those used in curved-faced CRTs - can be used in flat-faced designs.

These tubes are flat on the outside but have screens that are curved on the inside. As a result, the screen glass is thicker in the corners than in the center of the screen. To avoid an unnecessary decrease in luminance towards the corners of the screen because of the thicker glass, high-transmission screen glass is used in combination with a transmission layer on the screen.

The basic layout of the screen and mask of such a tube, as seen from above, is similar to the aperture-grill designs described previously, although the inner screen surface is even more curved. Again, the mask can be made more curved in the horizontal direction than the inside surface of the screen by applying screen-pitch grading. Design work basically consists of optimizing the screen-pitch grading and the wedge of the screen. A large wedge increases the curvature of the mask, improving doming performance as well as drop-test and microphony performance. However, the screen wedge cannot be too large because then the curvature of the internal surface becomes clearly visible, especially when the set is switched off or a crosshatch is displayed. Furthermore, the image then seems to lie deep in the cabinet, dark corners start to appear when the screen is viewed at an angle, and, perhaps most importantly, costs can increase.

As a result, tube designs must compromise between drop test, doming, and microphony performance on the one hand, and optical appearance and screen-pitch grading on the other. This approach has been adopted by Toshiba, Samsung, and LG, as well as by Matsushita for its wide-screen tubes.

The Philips Approach

The Philips designers started with the doubly curved mask technology for their new flat-faced "Cybertube," but they were not satisfied with the compromises required by other simi-

CRT technology

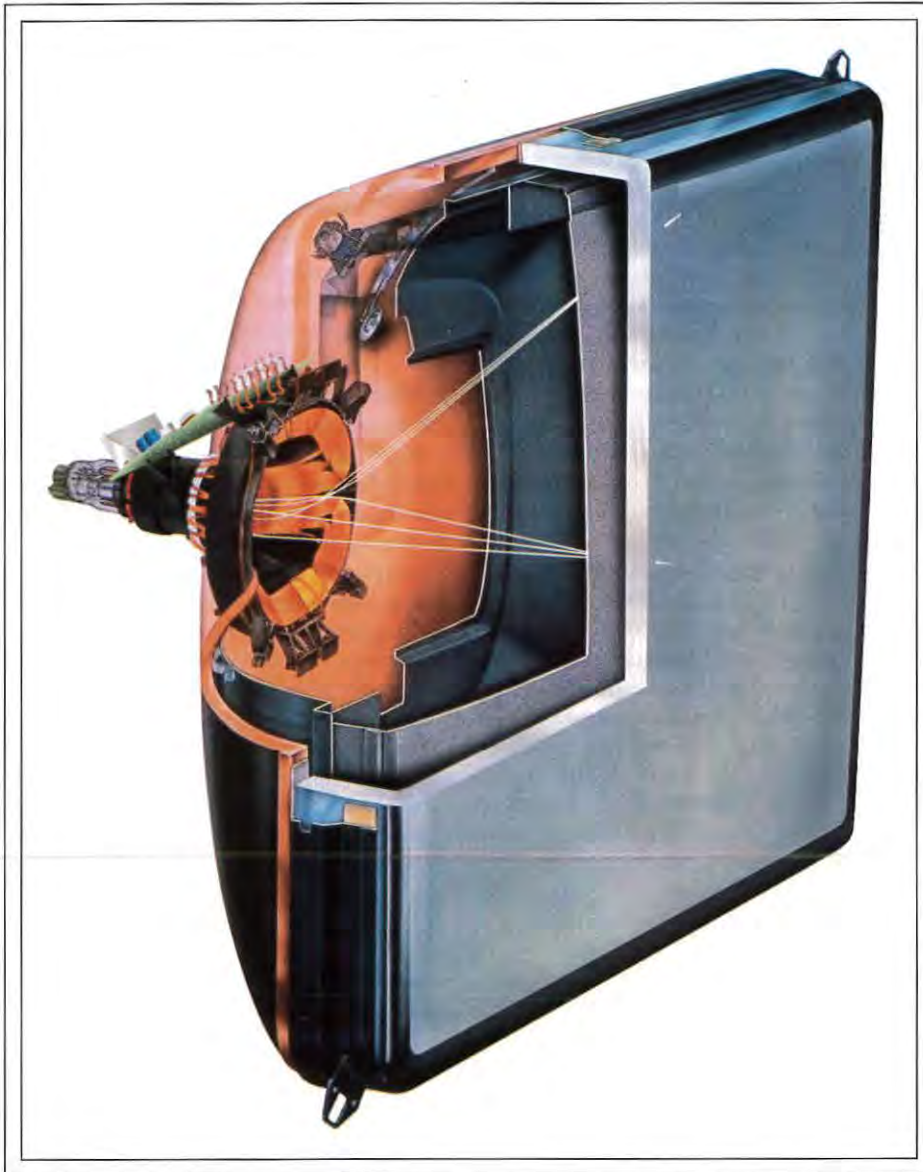

Fig. 5: This cutaway view of a Philips tube shows how the vertical mask curvature is greater than the inner vertical screen curvature, which is made possible by using gun-pitch-modulation technology.

lar designs. Instead, efforts were made to increase the mask curvature while reducing the screen wedge so that the image appears truly flat. *The key to this solution is modulating the gun pitch.* For a given screen pitch, the distance between the mask and the screen varies approximately inversely to the pitch of the gun. So by varying the gun pitch as a function of deflection, the mask-to-screen distance can be varied along the screen and additional mask curvature can be applied. In the

32-in. Cybertube, the vertical inner screen radius is 7.2 m, but the mask radius is only 1.9 m (Fig. 5).

It is not practical to physically move the electron guns to adjust the pitch, so it is virtually varied by means of a dynamic quadrupole that is placed over the gun of the tube. The convergence is then restored by means of a second quadrupole that is wound in a toroidal form around the core of the deflection unit (Fig. 6).

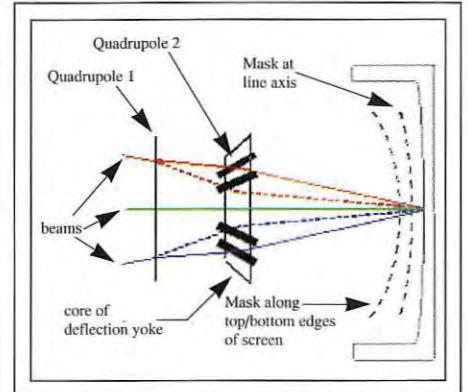

Fig. 6: Two sets of quadrupoles virtually change the gun pitch; the continuous lines represent the beams at the center of the screen, and the dashed lines represent the beams on their way to the top or bottom of the screen.

For reasons of reliability, only frame-deflection-dependent quadrupole currents are used, generated by a drive circuit integrated with the yoke. This circuit is frequency-independent, which means that it will work properly in multi-frequency sets.

All this results in a tube with an image that appears to be perfectly flat, a large viewing angle, a weight of 39 kg for a 32-in. tube, and a screen pitch that varies from 0.7 mm in the center of the screen to just below 1.0 mm along the screen edges, with good microphony, doming, and drop-test performance.

The gun-pitch-modulation technology is an effective step in the further development of flat-faced CRTs because it eliminates many of the compromises that designers must make, and the tubes can still be manufactured on conventional production lines. As a result, flat-faced CRTs may be able to compete effectively with traditional curved CRTs in the broader market. ■

SID '00

Long Beach, California
Long Beach Convention Center
May 14-19, 2000



SynTronic
SYNTRONIC INSTRUMENTS, INC.

A Half Century of Extraordinary Focus

The past 50 years have brought about dynamic technological changes in the CRT display field, eliminating most competitive manufacturers through the transitions. Syntronic, however, has continued to step-up and meet those challenges time and time again - where others could not. This is the reason why everywhere one turns in the electromagnetic component market, Syntronic's name and expertise is ever present.

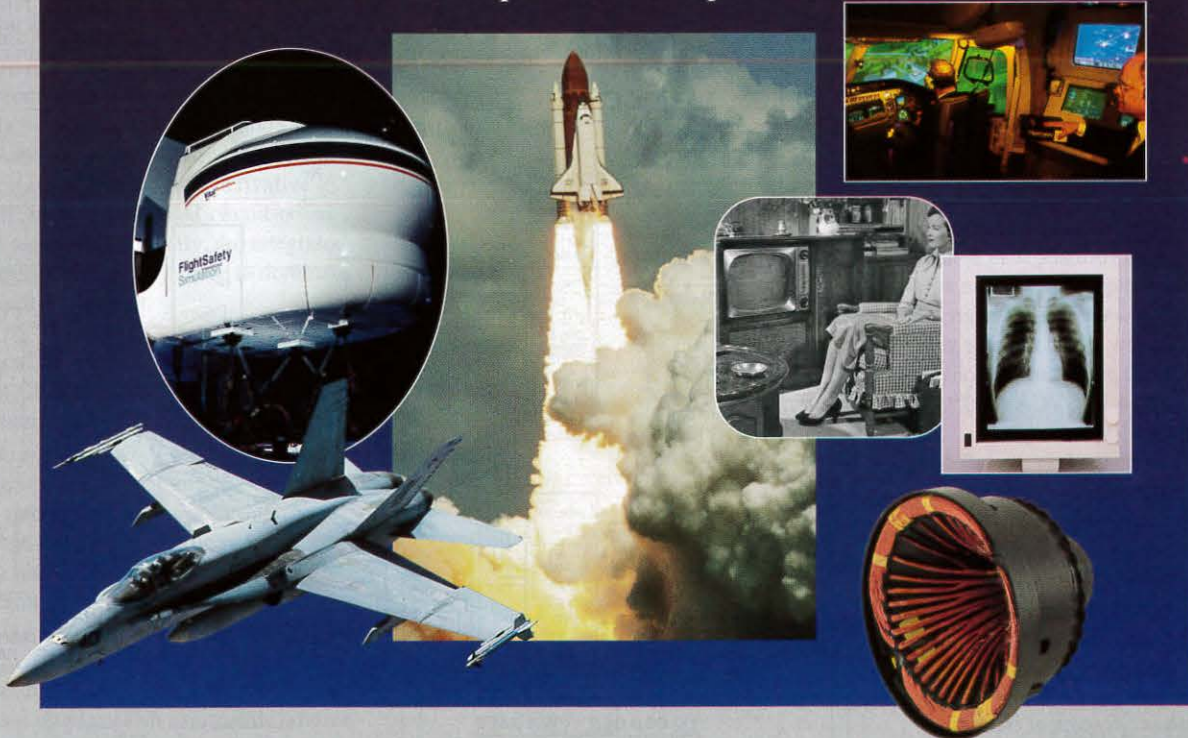

100 Industrial Rd. • Addison, IL 60101 • Phone: 630-543-6444 • FAX: 630-543-0287
E-MAIL: sales@syntronicinst.com • WEB SITE: www.syntronicinst.com

EASTERN REGIONAL OFFICE : 30 TWO BRIDGES ROAD, STE 330 • FAIRFIELD, NJ 07004 • PHONE: 973-808-6676 • FAX: 973-808-6860
WESTERN REGIONAL OFFICE: 28202 CABOT RD., STE 250 • LAGUNA NIGUEL, CA 92677 • PHONE: 949-365-1337 • FAX: 949-365-1341

Good Things in Small Packages

National Semiconductor has combined ac and dc approaches to increase the integration of display controllers for PC monitors, obtaining lower cost through fewer components and more efficient design.

by Andrew Morrish

IT'S EASY to be competitive in current markets; just make products more powerful and more compact than last year's models, and charge less for them. This high-stakes development race is familiar for computers, with 650-MHz processors at the high end and complete systems for less than \$500 at the low end, but it may not be as obvious to most observers that the monitor market is subject to the same acceleration.

After all, cathode-ray tubes (CRTs) rely on mature technology and displays based on them appear to have changed little from the first PC monitor. In fact, the performance gains in monitors rival those of computer processors. Today's monitors operate over a wide range of display formats, scan at high flicker-free refresh rates, and can even automatically align to new modes, yet at greatly reduced prices. A new 19-in. monitor with UXGA (1600 × 1200 pixels) resolution costs about as much as a 14-in. SVGA (800 × 600 pixels) monitor cost 10 years ago.

Success depends on the best overall design that meets the performance criteria with the lowest overall manufacturing cost. From processors to monitors, one key to success has been higher integration. Replacing two chips with one can result in lower component costs, reduced assembly costs, increased product reliability, and, ultimately, a better value for

Andrew Morrish is Director of Display Development at National Semiconductor Corp., 1090 Kifer Road, M/S C2-633, Sunnyvale, CA 94086-3737; fax 408/721-7321, e-mail: Andy.Morrish@nsc.com.

the buyer. In many cases, higher integration yields a simplified product design, reducing development costs and time to market, which are essential in today's competitive markets.

A better design for the video-amplification process in a CRT is one way of achieving higher integration. Early PC CRT displays generally used 300 or more discrete components to accomplish the task of video signal processing and amplification. The perfor-

mance was generally poor by today's standards, struggling to meet VGA bandwidths of around 20 MHz.

In 1995, National Semiconductor introduced the first three-channel monolithic high-voltage PC-display CRT driver amplifier. This amplifier displaced the handful of discrete components formerly used to amplify the video signal to the 45 V peak to peak required at the CRT cathode, bringing with it

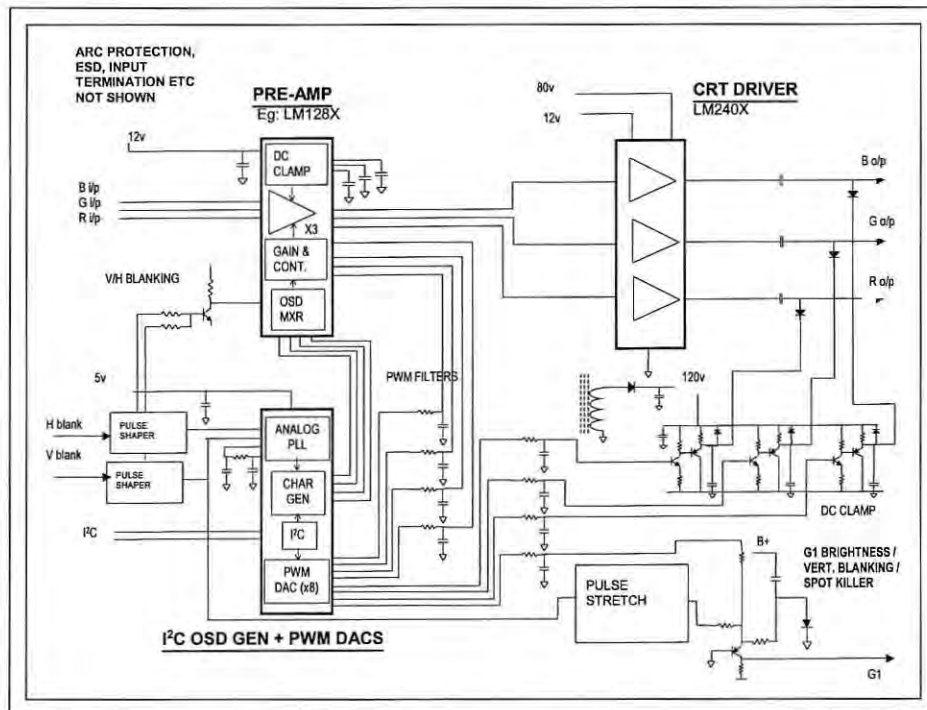

Fig. 1: A typical CRT video system relies on four blocks to amplify the video signals.

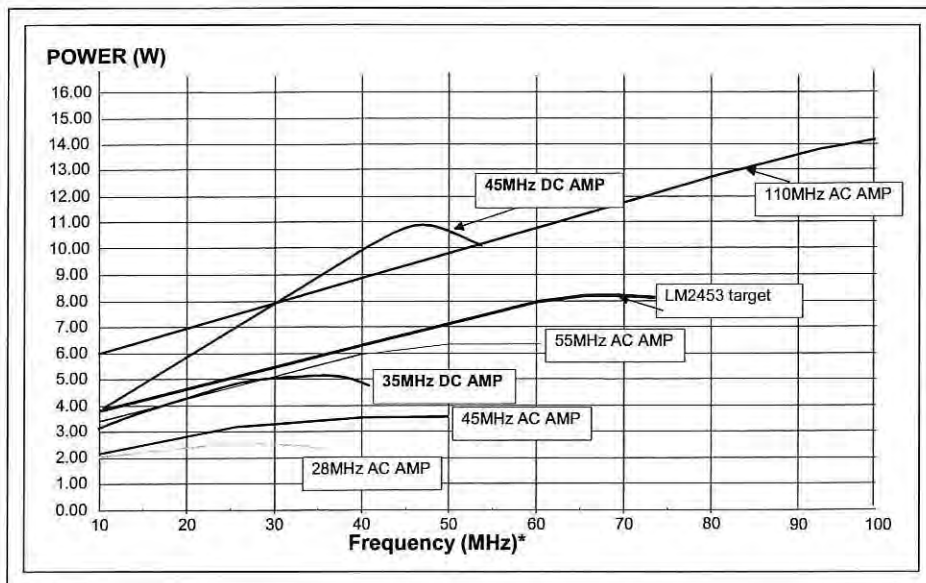

Fig. 2: The power dissipation of different amplifiers is related to frequency.

significant improvements in performance and manufacturing costs. Today, a comprehensive range of faster and lower-powered drivers covers the entire display spectrum, from VGA up to high-end UXGA applications. These monolithic three-channel amplifiers typically operate from an 80-V supply, producing cathode drivers at bandwidths up to and exceeding 100 MHz. The drivers use a common IC package and footprint, making it quick and easy to create faster or slower derivative designs from a single printed-circuit-board (PCB) design. Consequently, the integrated CRT drivers have quickly come to dominate the video driver market.

A Typical ac-Coupled Design

A typical CRT-monitor video channel consists of four interconnected circuit blocks (Fig. 1).

1. The standard 0.7-V red, green, and blue video signals created within the PC are ac-coupled into the preamplifier through an input coupling capacitor. The preamplifier typically uses a dc feedback loop and a separate dc sampling capacitor to servo the dc level of the signal within the preamplifier, so that the black signal level corresponds to a defined output voltage level. An analog multiplier gain stage uses an external dc control signal to normalize the amplitude, first to correct for variations in CRT gain, and secondly to adjust the ratio between the three channels for the desired white-color temperature. A

second control stage adjusts the gain of the three amplifiers simultaneously to provide a user control for contrast adjustment. Usually, the gain and contrast functions are controlled via a bus-controlled digital-to-analog converter (DAC) to allow for microcontroller operation. The preamplifier increases the amplitude of the video signal to around 3 V maximum.

2. The pre-amp output is directly coupled to the driver amplifier. The driver has a gain of around 14, amplifying the signal to approximately 45 V. The dc offset of this output amplifier is fixed in order to achieve the best linearity and transition times. The output is finally ac-coupled into the CRT cathode through arc protection and electromagnetic-interference (EMI) filtering components.

3. A number of discrete-component circuits set up the bias of the electrodes of the CRT. The dc level of the ac-coupled output signal is restored such that the black signal level corresponds to the point of zero beam current (otherwise known as "cutoff") in the CRT. In practice, the CRT dc bias level for cutoff may differ by up to 30 V between the three guns, due to mechanical tolerances within the CRT gun structure. To satisfy this requirement, the ac-coupled signal from the driver must be dc-restored through a clamp diode to an adjustable dc voltage set by the "bias clamp" amplifier circuit, generally set in the range of 80-120 V. A bus-controlled DAC typically controls this clamp voltage so that the setup of the CRT can be automated. Typically, the bias clamp amplifier consists of a simple two- or three-transistor discrete circuit for each channel. In addition to the bias clamp circuit, another small amplifier drives grid 1, mixing a vertical blanking signal with a DAC-controlled dc offset to produce the

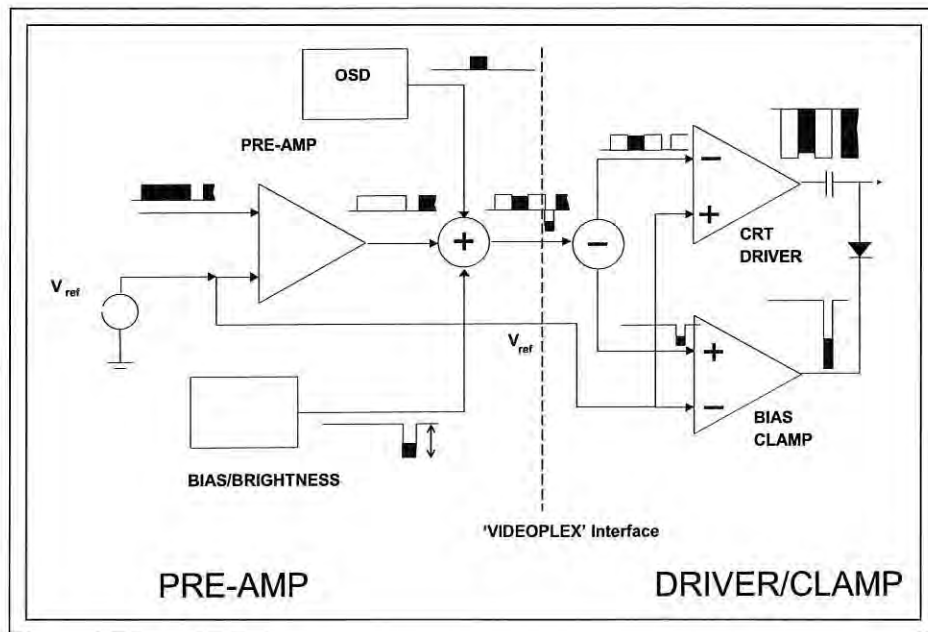

Fig. 3: The AC2DC system preamplifier relies on a 1.75-V system voltage reference.

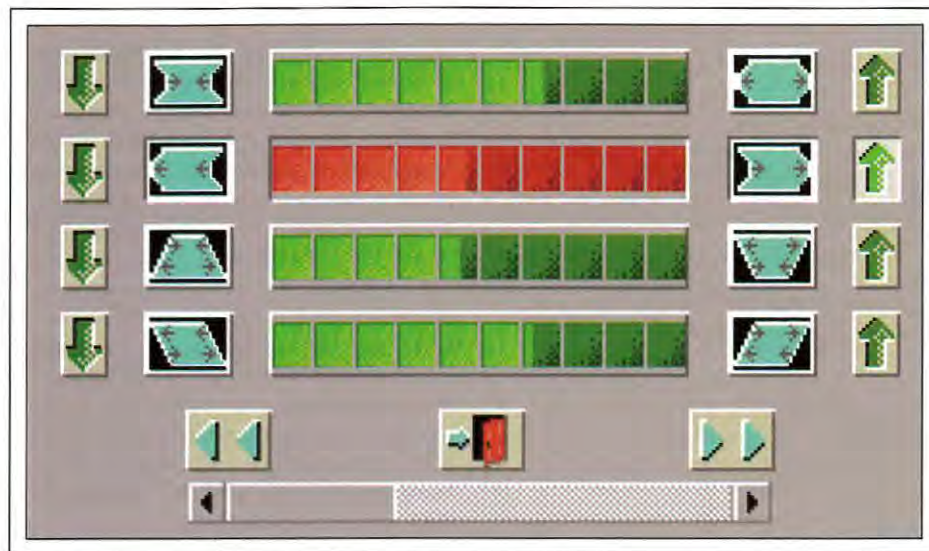

Fig. 4: The AC2DC design facilitates the creation of a more complex OSD images, which makes this feature more attractive and useful for end users.

dual function of brightness control and blanking during the vertical retrace.

4. A complementary metal-oxide semiconductor (CMOS) digital integrated circuit (IC) in the system usually provides an on-screen-display (OSD) signal to produce the adjustment menu in conjunction with the microcontroller. The digital red, green, and blue OSD video signals from the OSD device are mixed with the main analog video information in the preamplifier. A fourth digital signal controls whether the video or OSD information is being displayed. In addition to providing the OSD signal, eight pulse-width-modulation (PWM) DACs are often incorporated within the same digital IC. Although these DACs are noisy, they can be easily created within a digital IC at low cost. Because a digital bus typically controls this logic device, the set-up of the video signal and bias levels can be fully automated. One drawback of this implementation is that each PWM output requires an RC network to filter out the average dc level, and often some additional buffering to lower the effective DAC impedance. These additional discrete components add to the cost of manufacturing. More discrete components are also needed to form the clamping networks required to interface between the high-voltage scan system and the OSD synchronization inputs.

This basic design is popular across the entire range of displays, from low-end PCs to high-end workstations. Note that each func-

tional block uses the lowest-cost process implementation. The digital functions (bus controller, PWM DACs, and OSD) are inte-

grated in a CMOS process. The pre-amp is generally created in a high-frequency low-voltage bipolar process. The driver is best created in a specialized high-frequency high-voltage complementary bipolar process. The remaining CRT biasing functions have remained in discrete form because the slow discrete transistors are inexpensive compared with high-voltage integrated processes.

Despite this approach's popularity, there is still room for improvement; but some attempts at higher integration have resulted in lower performance or higher cost, or both.

dc-Coupled Designs

A second approach to reduce the component count is to use a dc-coupled video-amplifier design, which has been popular in TV receivers for some time. Here the bus and DACs are integrated into a more expensive BiCMOS preamplifier. In addition to processing the gain of the signal, the preamplifier adds a variable dc bias to the signal, and drives into a higher-voltage driver, running from a 110-V or higher supply. The output of the driver is dc-coupled into the cathode,

Table 1: Comparison between Different Video Systems

Parameter	ac-Coupled	dc-Coupled	AC2DC
System power	Good	Bad (50-100% more ac Power)	Good
Integration	Medium	Better (Approximately 40 components less)	Very good (Approximately 70 components less)
Neck card weight	Fair (Smaller heatsink)	Worse (Heavy heatsink)	Very good (Smaller heatsink)
Neck card size	Good	Better (Approximately 20% smaller)	Best (Approximately 30% smaller)
Layout complexity	Medium	Easier	Easiest
Variation in T_r/T_f with dc	No change	Poor (Approximately 20% variation with dc offset)	No change
dc adjustment range	Good	Poor (Approximately 30 V)	Very good (>60 V)
Video dc supplies	120 V, 80 V, 12 V, 8 V, 5 V	110 V, 9 V, 8 V, 5 V	80 V, 8 V, 5 V
Vertical blank pulse	Discrete	Discrete	Integrated

eliminating the requirement for a coupling capacitor and a dc recovery circuit.

The lower component count can reduce manufacturing cost and improve quality, but the dc design concept has several significant problems that make its implementation impractical for most high-quality PC display applications:

1. Power dissipation in the CRT driver amplifier is predominantly caused by providing the energy required to charge and discharge the capacitive load at high pixel frequencies. The amplifier itself has a dc quiescent power component, but this is usually insignificant compared with the ac component, as can be seen by the typical power-dissipation curves (Fig. 2). Unfortunately, the ac power dissipated by an amplifier driving into a capacitive load is directly dependent upon the power supply rail. For this reason, an amplifier operating from 120 V dissipates 50% more power than the same amplifier running from 80 V.

2. Higher-voltage IC process devices require thicker, lighter-doped structures, resulting in higher-resistance collector

regions, lower transition frequencies, and poorer "soft-saturation" characteristics. The larger structures consequently result in much higher capacitance between collector and base (or drain and gate in FET devices) and collector and substrate (drain and substrate). The result is that higher-voltage devices are intrinsically slower than lower-voltage devices.

The speed will be primarily dictated by the parasitic capacitances within the devices; the higher these stray capacitances are, the lower the node impedance must be made, resulting in a need for lower load resistances, and thus higher power.

As a result of this, the actual ac power dissipation of a 50-MHz-bandwidth amplifier designed to run off a 120-V supply in dc configuration is about double that of a comparable 80-V-rated amplifier. Higher power requires more expensive heat sinks, more expensive higher-rated power supplies, and may even require more expensive higher-melting-point plastic to be used in the cabinet casings. The lowest-cost physical implementation is to mount the video card on a small PCB, directly connecting to the CRT neck

where the CRT socket is the only physical mount available. Heavy heat sinks require additional brackets or shock protection to prevent the video card from either breaking the CRT neck or becoming detached in shipment.

Higher power requirements are not the only drawback of dc-coupled systems: CRT monitor designers primarily seek very stable high-frequency performance at the cathode of the CRT. Too much overshoot causes ghosting and ringing, and can also be a major cause of EMI. Slow transition times result in poor vertical-line or single-pixel luminance. Variations in performance between the three channels become easily visible as an objectionable change in the color point of white vertical lines displayed on the screen. The dc-coupled amplifiers must maintain the same high-frequency transition performance irrespective of the dc operating point. For the IC designer, this is an extremely difficult task, because the internal device parasitic capacitances that limit the frequency performance of the amplifier vary considerably with operating voltage. This can result in an under-damped response at one dc output voltage, turning into unacceptable ringing as the dc level is altered, or completely different responses between two of the channels due to different bias-level tolerance requirements.

It is worth noting that the dc-coupled systems have prevailed in domestic TVs, even though higher-voltage signal swings are required. There are several reasons why this is the case.

1. The signal swings can be more than double those in a PC monitor, so the difference in supply rail for a dc- and an ac-coupled system is not so great in a television.
2. The bandwidth requirements and average ac signal swings are much lower, so the ac power dissipation is also much lower.
3. The device parasitics are not so significant at these lower frequencies.
4. The typical TV image does not contain large-amplitude single-pixel transitions, so single-pixel performance requirements are not so severe.

The Best of Both Worlds

The performance and low power dissipation of an ac design coupled with the complexity of a dc design would be an attractive solution. The National Semiconductor displays team had this goal in mind for the new "AC2DC"

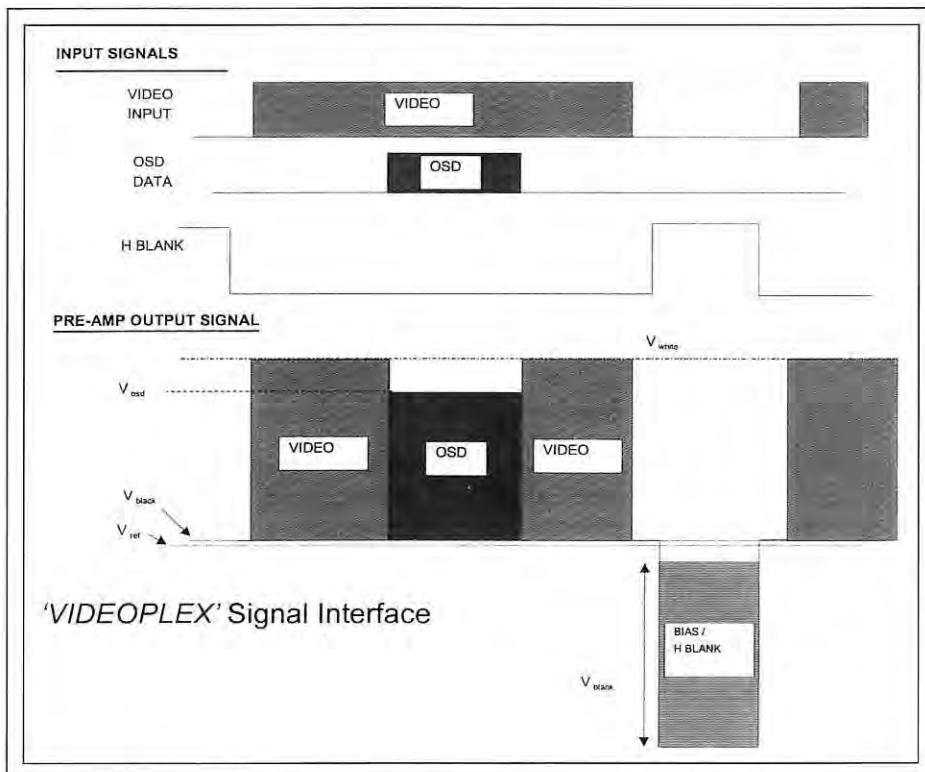

Fig. 5: The Videoplex signal multiplexes the video input and OSD data, along with the horizontal-blanking signal.

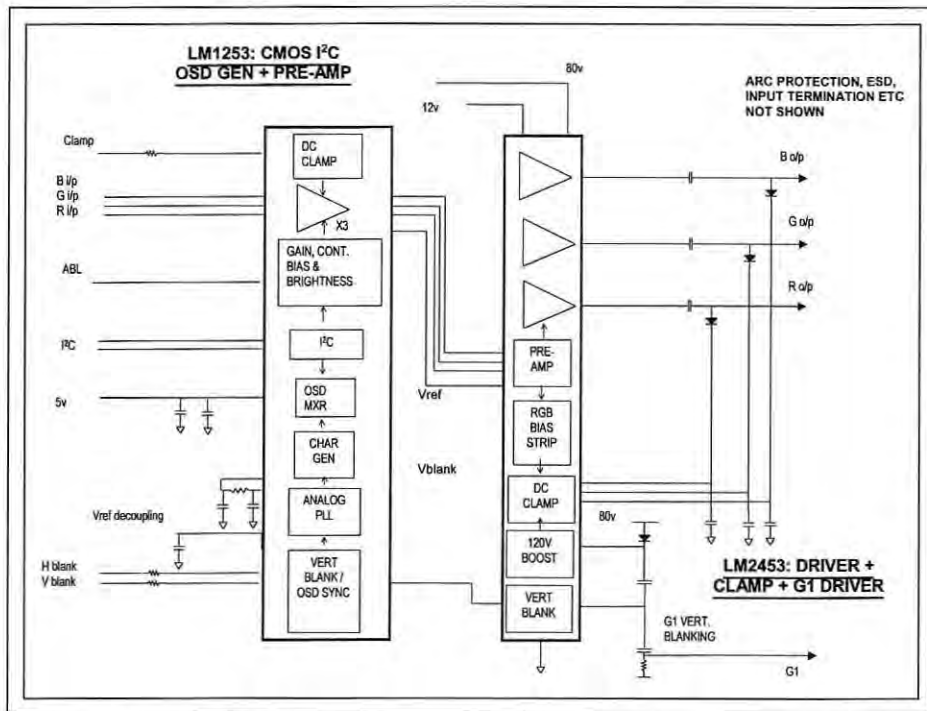

Fig. 6: The AC2DC video system greatly reduces the required number of components.

system, with four objectives guiding development:

1. Re-partition the functional blocks so that each block could be realized using the lowest-cost process. For the design team, this meant using standard 0.5- μm 5-V CMOS processes wherever possible, and the National Semiconductor VIP3H bipolar process.

2. Sweep up as many external "string-and-glue" interface components as possible, such as the discrete devices normally needed to interface between the high-voltage blanking signals and the OSD generator, and the PWM filter components. The goal was to reduce the component count as much as possible.

3. Re-use existing basic driver designs – already widely accepted within the industry – as much as possible.

4. Take advantage of the integration possibilities to try to achieve a higher level of system performance than was possible with today's high-component-count topologies.

CMOS linear voltage swings are limited, so creating the linear preamplifier functions in CMOS meant that the total system gain would have to be reallocated: the preamplifier gain would have to be reduced and the driver gain increased to achieve the overall

system gain of around 70. A modest video output signal swing of 1.25 V was allocated to the CMOS preamplifier, requiring an increase in gain to around 50 in the driver. Higher gain in the driver meant that the output dc level of the driver would be more susceptible to variation because of manufacturing tolerances between the output dc level of the preamplifier and the input of the driver. The dc feedback from the output could be used to overcome this – as is required by most dc designs – but this would require discrete feedback devices, which would be undesirable in terms of both complexity and ac performance.

To overcome this problem, it was decided to create a 1.75-V system voltage reference in the preamplifier. The output signal of the preamplifier is set up relative to this reference, and passed along with the reference signal to the driver. Each driver amplifier shares this single common dc reference (Fig. 3). By simply using a differential input stage with a gain of around 3.5 times that of the present-day ac-coupled driver amplifier, improved common-mode rejection can be achieved with minimal modification to the driver circuitry. Any variation in the reference voltage due to semiconductor manufacturing process variations is

simply rejected by the system as common-mode noise.

Digitally controlled gain cells within the preamplifier directly control the signal gain to achieve the functions of gain and contrast, with an additional analog control input to facilitate automatic beam-limit control. No external filter components are needed for the gain cells, thus eliminating many discrete components. The gain cells do not add any significant dc offset to the signal, so dc recovery of the input signal can be achieved at the input, using the ac input coupling capacitor also as the dc restoration capacitor. Because the input impedance of the CMOS amplifier is very high, only a small capacitor is required to maintain this dc set-up, which also eliminates the need for a second dc restoration capacitor.

Placing the preamplifier analog functions in CMOS makes it easy to integrate the OSD generator and bus circuits with a wider interface between the two circuit blocks. Instead of a restricted palette of eight colors using the conventional three-wire OSD video interface, the newly designed OSD generator produces 3 bits per color of OSD information, allowing for a total palette of 512 colors. The OSD digital video information drives a high-speed 3-bit DAC in each video channel, creating an analog OSD video signal, which can be directly integrated seamlessly with PC-derived analog video information. Because the OSD video or insertion signals never leave the IC, minimal transition delays are encountered when switching between OSD and video signals, eliminating many of the shadowing or overlapping effects commonly encountered in normal systems. Also, the direct integration means that the overall pin count can be reduced, integrating the functions of a 28-pin video IC and a 24-pin OSD IC into a single 28-pin package, yet achieving the improved functionality of analog OSD.

The I²C-compatible bus interface circuit drives both the preamplifier and the OSD generator, thus eliminating replication of function. A new compact programming protocol allows not only maximum flexibility of the shape, size, and color shades of the OSD menus, but minimizes code overhead in the monitor microcontroller by using a 16-entry attribute table to specify independently the colors and features of each character displayed. The generator also provides 64 characters with four colors per character, allowing intricate icons that approach those of typical Windows appli-

cations (Fig. 4). The end result is an improved, more ergonomic user interface.

The integration of the level-clamping circuits usually needed to interface to the high-voltage analog scan waveforms makes it easier to interface to the preamplifier and OSD. Series current-limiting resistors directly connect the horizontal and vertical flyback signals, and the required digital level signals are then created within the IC. The vertical blanking duration - normally set by external RC-timing components - is set by an internal programmable counter, allowing greater flexibility.

The signal at the output of the driver thus resembles that of a conventional ac-coupled driver. A horizontal blanking voltage is impressed upon the video signal, causing the driver to saturate at the supply rail during horizontal flyback, thus preventing any visible video during this period. This "blacker than black" blanking level becomes the pedestal upon which the signal is dc-restored by the bias clamp circuits integrated within the driver amplifier. The bias clamp amplifier sets up the voltage on a reservoir capacitor to which the ac-coupled output signal is dc-restored, similar to any other ac-coupled system. The bias clamp amplifier has an active range of 60-120 V, running from a 120-V supply. It is a "gated" clamp amplifier, in that the amplifier is only functional during the horizontal blanking time. During this period, it discharges the dc reservoir capacitor to the required level. During the active video time, the amplifier is turned off, thus minimizing the additional power required by the clamp amplifier to only a few hundred milliwatts.

Normally, a gated bias clamp amplifier is presented with a dc input signal and the horizontal rate gating pulse. In the new AC2DC system, the bias clamp amplifier takes its signal from the level of the horizontal blanking pulse on the video signal being sent to the driver from the preamplifier. Whenever the video blanking signal drops below the 1.75-V system reference level, the driver amplifier is sent into saturation. Conversely, when the signal drops below the reference level, the bias clamp amplifier is turned on and amplifies the difference between the blanking signal and the system reference to set the bias clamp voltage. By varying this blanking pulse, the bias clamp potential can be adjusted and used to control both the cutoff voltage for dc bias set-up and also the variable brightness voltage.

The single video signal from the preamplifier contains the video information, the OSD information, the horizontal blanking information, and the bias clamp information, all multiplexed into a single signal referenced to a common system reference voltage (Fig. 5), called the "Videoplex" signal.

By using a single signal in this fashion, many IC I/O pins are eliminated on both the preamplifier and the combined driver and bias clamp IC, reducing chip size and the number of pin-to-pin interconnects on the video card.

The Videoplex signal itself is generated within the CMOS preamplifier. Bus-controlled DACs set up the bias and brightness dc levels that are switched into the video signal during the horizontal retrace period.

One other potential advantage of a dc amplifier is the need for only one supply rail; ac-coupled systems typically need an 80-V supply for the driver and a second 120-V supply for the bias clamp amplifiers. The AC2DC approach eliminates the need for an externally supplied 120-V supply rail by creating an onboard 40-V pulse, and then using this to provide a 40-V boost supply stacked on top of the 80-V supply. The 40-V pulse is obtained from a small integrated vertical-blanking amplifier that takes the vertical-blanking pulse and amplifies it to the required amplitude. This pulse is ac-coupled into grid 1 to achieve flyback blanking during the vertical period, and also to provide the 120-V boost supply, thereby eliminating the need for an additional 120-V winding on the main power supply.

The final two-chip AC2DC system reduces the component count, yet maintains all the advantages of lower power and consistent high-frequency performance (Fig. 6). The new approach offers the best of ac- and dc-coupled designs, as summarized in Table 1.

This higher level of integration can help monitor manufacturers continue to provide the improved performance with reduced component counts - and the resulting lower production costs - that will be required to maintain a competitive position in today's market. ■

Please send new product releases or news items to Information Display, c/o Palisades Institute for Research Services, Inc., 411 Lafayette Street, 2nd Floor, New York, NY 10003.

Let us
enhance
your
display!

**The Polar
Vision**

- **Engineering Excellence**
- **Versatility**
- **Customization**
- **Convenience**

Polar Vision is a leading manufacturer of optical filters for contrast enhancement, sunlight readability, viewing angle control, vandal resistance, anti-glare, EMI/RFI shielding, and anti-reflection — for CRT's, ATM's, touch screens, and flat panel displays. In addition we manufacture a full range of custom linear and circular polarized films and retardation films for use in information display products. Our facilities offer class 100 Clean Room optical lamination capabilities for rigid to rigid, flexible to rigid and flexible to flexible materials.

As a full-production facility with a uniquely qualified engineering staff, Polar Vision is your ideal outsource alternative.

POLAR VISION INC.

625 Alaska Ave. • Torrance CA 90503
800.269.8801 • FAX 310.320.9357

sales@polarvision.com
www.polarvision.com

See Us at SID '00 Booth 539

Circle no. 21

AREA UNIFORMITY CHECKED IN LESS THAN 30 SECONDS ?

- > 2D MURA defects analysis. (Luminance, Contrast, Color).
- > High accuracy, sensitivity, resolution through 16 bits high grade cooled slow scan CCD.
- > User friendly Windows based software platform. Production tests automation through ActiveX.

MURATest Family

Available optics :

- > Conventional Video-colorimeter optics
- > Telecentric optics
- > Virtual Vision optics

Applications :

- > LCD, FED, Microdisplay, Dashboards...
- > Ergonomy Quality Control...
- > R&D...



© ELDIM SA - 2000 / Aug014 - V1.0



ELDIM

ELECTRONICS FOR DISPLAYS
AND IMAGING DEVICES

1185 rue d'Epron 14200 HEROUVILLE SAINT CLAIR - France • Phone : + 33 2 31 94 76 00 - Fax : + 33 2 31 94 09 50
E-Mail : eldim@eldim.fr • Internet address : http://www.eldim.fr

See Us at SID '00 Booth 225

Circle no. 22

High Quality (Industrial) TFT-LCD at an Affordable Price

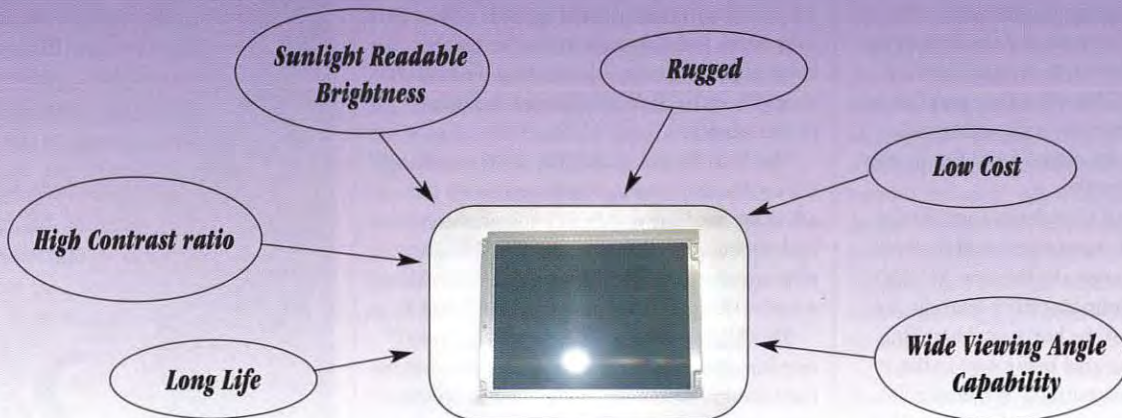

An Affordable High Quality
TFT-LCD

Vertex LCD Company, Engineered for Excellence!

Vertex LCD Company www.vertexlcd.com Tel:714.223.7111 Fax:714-223-7711
600 S. Jefferson St., Unit K, Placentia, CA, 92870

See Us at SID '00 Booth 314

Circle no. 23

MICROJOIN, INC
Poway, CA 858/877-2100

ACF Bonding System for FPD

The Model 6800 is a computer controlled ACF bonding system. It can perform TAB and chip-on glass assembly operations on flat panels of up to 40" (1.02M). It is ideal for high mix, low volume assembly or rework environments. The system incorporates MicroJoin's Ceramic Hot Bar Technology™ providing highly repeatable part co-planarity and superior heat conduction. The 6800 features high precision hot bar z-axis actuator for pressure control, vision alignment system option for parts to 90 microns, multi-axis motion system,

Windows NT-based operating system. The computer controls motion, vision, lighting, and logs process parameters for SPC analysis. The system is Class 100 clean room compatible.



Circle No. 1

Hot Bars Better Bonds



ACF BONDING

HEAT SEAL BONDING

REFLOW SOLDERING

Ceramic Hot Bar Technology™ (CHBT™) from MicroJoin assures process control and part consistency for ACF, heat seal, and reflow solder bonding processes. MicroJoin's CHBT performs with exceptional flatness and part co-planarity, very low thermal gradients, complete electrical isolation from the parts, and no oxidation build-up.

Even more, these critical process features can be demonstrated under a wide range of dynamic conditions. MicroJoin has over 25 configurable system platforms to meet specific application requirements. Stemming from its Toddco General, Palomar, and Hughes roots, MicroJoin has more than 50 years of combined expertise.

You can use Ceramic Hot Bar Technology for flex-to-glass, flex-to-flex, flex-to-PCB, chip-to-glass, edge connectors, ribbon cable and more.

Contact Us Today...

Phone: 858 877-2100 e-mail: hotbars@microjoin.com

micro
Join
A Filmer Technologies Company

MICROJOIN, INC
Poway, CA 858/877-2100

Polarizer Laminator for FPD

The Model 6300 is an all new workstation for application of polarizing film to flat panel displays diagonals of up to 21" (533mm) with an aspect ratio of 4:5. The 6300 features five standard roller lengths for a variety of film sizes and vacuum hold-down for LCD panels. Lamination repeatability is +/- 0.3mm. Typical cycle times range from 39 to 66 seconds including load/unload. The system is Class 100 clean room compatible.



Circle No. 2

MICROJOIN, INC
Poway, CA 858/877-2100

4200 PDI for LCD Module Bonding, Testing

The 4200PDI provides two bonding and two testing positions for LCD module assembly. Using two bond heads with MicroJoin's Ceramic Hot Bar Technology™, the 4200 can increase throughput by a factor of three times. While two modules are bonding, another two are tested then unloaded. Its computer controller and camera provide real-time viewing of LCD pixels for quick assessment of bond quality.



Circle No. 3

See Us at SID '00 Booth 431

Bringing the NEC 20-in. LCD to Military Customers

Skepticism about using COTS glass in military displays and mysterious flickering in a key Navy application were two hurdles that had to be overcome before customized commercial LCDs became accepted in critical military applications.

by Mike Forde

THERE was a lot of excitement in 1997 in the rugged-display community when NEC was about to go into production with their new 20-in. 1280 × 1024 active-matrix liquid-crystal display (AMLCD). It was anticipated that this would be the largest production high-resolution LCD for the next several years and that it would finally offer a real CRT-replacement technology for the Command, Control, Communications, Computer, and Intelligence (C4I) market. Up to this time, the most common display technology for this market had been the 20-in. (19-in. viewable) commercial CRT that was ruggedized by a handful of competing companies (Fig. 1). Thousands of these displays were installed worldwide in military aircraft, ships, shelters, and command centers. The IBM/Toshiba 16.1-in. display had been the first high-resolution LCD usable for this market, but was generally regarded as an interim solution while the community waited for a real 20-in. CRT replacement. By 1997, many of the serious obstacles to the widespread use of LCDs for military applications had been overcome, or were rapidly

Mike Forde is Product Group Manager of Rugged Displays at BARCO NV, Display Systems, Th. Sevenslaan 106, B-8500, Kortrijk, Belgium; telephone +32-56-23-3255, fax +32-56-23-3013, e-mail: mike.forde@barco.com.



BARCO Display Systems

Fig. 1: The standard high-resolution display for military applications has been the commercial 19-in. CRT as ruggedized by one of several military contractors, but its inherent bulk and weight invites replacement by an appropriate flat-panel monitor.



Lockheed Martin

Fig. 2: In early 1997, competition was announced by Lockheed Martin Tactical Defense Systems to replace the CRTs in the AN/UYK-70 (Q-70) console with 20-in. flat panels, which created an opportunity for NEC's 20-in. AMLCD.

being overcome, and the rugged C4I market was ready to switch from purchasing primarily CRTs to LCDs. All that the market needed was the right diagonal size and experienced companies to begin the proper ruggedization of these displays.

Recognizing the potential impact on the C4I market, BARCO aggressively pursued the purchase of the first production 20-in. LCDs. When the display was introduced at SID '96, BARCO immediately opened a dialogue with representatives of NEC to secure the first panels. Prior to introducing a new product, a significant amount of testing and characterization of the new LCD would be required to ensure that the display would provide the needed performance for the market. The 20-in. panel was a new technology. It was the first with in-plane switching (IPS) and was a direct analog-input panel.

In parallel, BARCO's competitors, realizing the same potential, set out to obtain the panel themselves. Through a concerted effort and close cooperation with NEC, BARCO

was able to obtain a commitment to be one of the first to get a prototype and the first to get production panels. After obtaining this commitment and challenging our engineering organization to be the first with a rugged 20-in. LCD product, BARCO set out to market our strategy and convince our customers that we had the technology and the capability to make the first 20-in. rugged flat-panel display (FPD) in the world – and that it would do an excellent job of meeting our customers' needs.

In early 1997, competition was announced by Lockheed Martin Tactical Defense Systems (LM TDS) to replace the CRTs in the AN/UYK-70 (Q-70) console with 20-in. flat panels (Fig. 2). At that time, BARCO was supplying the Q-70 program with CRT displays and it became a "must win" for BARCO to maintain its Q-70 business as LM TDS began its transition to flat panels for the U.S. Navy.

The competition was held to the strictest procurement standards. After a long and diffi-

cult proposal cycle, it was announced that the display contract would be awarded to BARCO. But it was incumbent on BARCO to strictly meet LM's schedule requirements in order to remain on the program. If BARCO were to miss the schedule commitments, there were other competitors who would gladly step in.

The first prototypes were due even before the ink on the contract was dry. The next deliveries were due in 3 months, and the first delivery of production-ready hardware was 6 months after the award of the contract. To develop a new product using a new and unproven technology in 6 months posed a serious risk to LM and to BARCO. However, LM judged that BARCO had the right mix of experience and supplier relationships to make it work.

In September 1997, the third month of the development, we began to hear rumors that the 20-in. flat panels showed a luminance flash when used with Navy sonar programs, one of the primary applications for our design. In the beginning, we shrugged it off as competitor "noise." But when the reports started coming in through our sales team from several unrelated sources, we listened. At about the same time, LM TDS informed us that the flashing was verified by their engineers and that the U.S. Navy was convinced that the 20-in. technology was the problem. There was a growing concern that the 20-in. technology would not work for sonar and other C4I applications. Had we made a mistake in technology choice?

BARCO immediately assigned the investigation to our central research lab. By November, the lab had identified the source of the flashing. By then the display community had settled on a name for the problem – "LCD flicker" – because the display appeared to flicker when applications with slow-moving high-contrast data were displayed. But the rumors persisted that it was just a problem with the 20-in. technology, and that other LCDs did not present this problem. BARCO's engineering set out to determine the truth.

After only a month of research, BARCO announced that we had determined the cause of LCD flicker and that it was not specifically related to the 20-in. LCD, but showed itself on all LCDs. In fact, the phenomenon could also be observed on CRTs, but was not visible to the human eye. In January 1998, BARCO was told that a solution was required and that

case study



BARCO Display Systems

Fig. 3: When sonar operators first attempted to use 20-in. LCDs to view "waterfall-gram" data from sonobuoys, as pictured here, a disruptive blinking made it impossible for them to do their jobs.

the U.S. Navy wanted to see a solution fast. However, and importantly, the myth that the problem was due to the 20-in. technology had been quashed.

Now, in addition to racing to complete the design for a new rugged LCD product in a very short period of time, we had a new challenge to overcome: how to solve the flicker problem. BARCO's engineers had proved that flicker was caused by the difference in the rise and fall times of LCDs, but implementing a solution was far from simple. There were many related parameters that had to be controlled in order to eliminate flicker. It would take much longer to develop a robust solution for this one problem than it had taken to develop the basic display product itself. Both the U.S. Navy and LM were impatient and wanted a solution. After we fully explained the difficulties, it was agreed that during the investigation and development BARCO would provide demonstrations of our progress to both the Navy and LM. These demonstrations served to show our customer that real

progress was being made, but, more importantly, it provided a way to validate our progress and to create a team approach to solving a difficult technology problem. Together the team would decide when BARCO had defeated the flicker problem, and only then would we be authorized to include that solution in our product. Everyone was to be a part of the solution.

What Causes LCD Flicker?

In the normally white 20-in. LCD, flicker is characterized by a momentary drop in luminance. The rate of this luminance change is determined by the update rate of the data being displayed. All LCDs, to a greater or lesser extent, exhibit this phenomenon. It is best viewed in an image consisting of about 90% dark pixels and 10% light pixels, randomly distributed throughout the viewable area (Fig. 3). As this data is scrolled down the screen (in what is called a "waterfall" by the Navy sonar community) or across it, there is a perceived change of luminance. This can be

simulated on any laptop computer by minimizing an application and moving it slowly around the LCD. It can also be seen on an airliner's video LCDs when the black-and-white credits are scrolling at the end of a movie.

LCD flicker was originally thought to be directly related to the overall response time of the LCD. The 20-in. panel has a slow overall response, so it was assumed that this was the source and that there was no way of compensating for the effect. Fortunately, it was determined that it is the difference in the rise and fall times that causes flicker, not the total value.

Let us assume that we have two adjacent pixels and that the fall time of the pixels is much faster than the rise time. Additionally, one pixel is fully off and the other is fully on. If the pixels receive a command to go to the opposite state, then the pixel that is fully on goes off before the pixel that is fully off comes on. If this event occurs over a large area containing a large number of pixels, then the eye sees a momentary decrease in luminance while the pixels that are fully off take a bit longer to reach the fully on state. The optical-response curve that is at the source of the problem is commonly seen in many LCDs (Fig. 4).

Once the real problem was understood, it was necessary to find a solution for it. Initially, this could be done quite simply. Our engineers made a simulation in which the fall time of the optical response was rebuilt to match the rise time. These algorithms were developed in January 1998 and demonstrated to LM TDS and the U.S. Navy to show that we could indeed solve the problem. They were satisfied, but they asked for a hardware implementation that showed the same results, and asked to see this demonstration in May 1998.

An algorithm running on a computer was one thing; developing a hardware solution in a few months was another. As we all know, the pixel response of an LCD dramatically changes with temperature. Any solution would have to focus on the changing temperature, especially in the military market, where operation over a large temperature range is required. It was also determined that the optical response varies with gray-scale demands; therefore, any robust solution must apply compensation on a pixel-by-pixel basis using a synchronous system. That means a robust solution must avoid frame-rate conversion

LCD-Flicker Is a Result of the Difference in Pixel Rise and Fall Time

Ideal Input vs. LCD Optical Response Curve

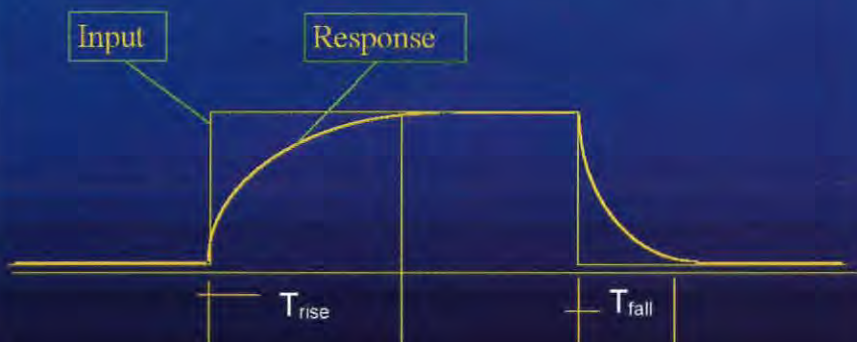

Fig. 4: This optical-response curve, with T_{fall} much shorter than T_{rise} , is what causes the once-mysterious blinking phenomenon called "LCD flicker."

which could add unwanted artifacts and bring the integrity of the solution into question – and do so without any change in the overall commanded pixel value.

Compensation is the process of matching the rise and fall times by considering the response of the pixel under real-time conditions, including temperature and gray level. A complex set of compensation algorithms had been developed to interrupt this real-time information and perform the necessary compensation. Now, these algorithms had to be implemented in hardware with the necessary panel feedback.

In May 1998, BARCO demonstrated its solution. We were able to show a new LCD interface board that compensated for the difference in rise and fall times. The results were impressive, and both LM and the Navy agreed that this was the right solution. They then asked the Naval Undersea Warfare Center (NUWC) to take displays with the flicker-compensation solution in place and perform an evaluation to ensure that the ability to detect sonar targets was not diminished in any way. This evaluation took place over several months. In September 1998, NUWC reported that there was virtually no change in the abil-

ity of these displays to detect sonar targets. The BARCO LCD flicker compensation (LFC) solution had worked. LM informed BARCO that they wanted production deliveries of units with LFC by the end of the year.

Our challenge did not end there. During this period, our competitors were trying to find a way to unseat us from the Q-70 program. We heard many reports of companies that allegedly had solved the problem. We never saw any demonstrations of these solutions at trade shows, nor did we hear of any acceptable demonstrations to our customers. However, the claims were enough to cause LM to question our solution and want to make sure that we were doing just enough to solve the problem – not more, not less. LM was being told that the flicker problem could be solved in many ways which were much simpler and quicker than BARCO's approach, but for proprietary reasons no details could be revealed. But from the display-community rumor mill, we heard that some companies were simply adding a significant delay to the overall response time, or they were lowering the contrast, or varying update rate, or combinations of all these methods.

Any of these solutions could reduce flicker,

but they were not robust solutions. To eliminate flicker by delaying the fall time, the response time of the pixels would have to be increased to an unacceptable degree. And with changing temperature, the results would not be consistent. Changing the contrast or controlling the update rate did not really solve the problem; it merely masked it. Neither of these solutions is acceptable for the C4I community. Only a solution that takes into consideration all the parameters that affect pixel response and that compensates directly for these effects can assure that a display operator working in a rugged environment is seeing a true and uncorrupted representation of sonar returns. We continued with our implementation, because we believed it was the right solution.

We believed in the solution, and we filed for patent protection in the U.S. and internationally in 1998. A European patent was awarded in December 1999 and a U.S. patent is pending and expected to be awarded in mid-2000.

By December 1998, we had begun production and delivery of our 20-in. panel with LFC to Lockheed Martin Tactical Defense Systems for the Q-70 program and to other customers as well. We have continued development and are now on our third generation, improving the overall compensation and adding more features to the interface card, such as automatic phase adjustment and auto-calibration. To date, we have yet to face a head-to-head display-off with any competitor claiming to have a superior LFC solution. ■

SID '00

Symposium, Seminar,
and Exhibition

Long Beach, California

Long Beach Convention Center

May 14–19, 2000



Redefining capacity.

Micronic is at the forefront in display photomasks and now offers the multi-beam pattern generators for increased productivity at maintained precision. We have created an innovative way of writing complex patterns in a highly cost-effective way.

We help our customers become world-leaders. If your business employs high-precision microlithography, and you are ready for the next step forward, you are invited to contact Micronic.



MICRONIC LASER SYSTEMS AB (publ.) | Box 3141, SE-183 03 Täby, Sweden | tel: +46 8 638 52 00 | fax: +46 8 638 52 90 | e-mail: info@micronic.se | website: www.micronic.se

See Us at SID '00 Booth 927

Circle no. 24



Maybe you're not as bright
as you think you are.

(In reference to your display, of course.)



No matter how bright you think your display is, chances are, we have a film that can make it brighter. We offer multiple enhancement solutions for the electronic display industry, including transmissive display products and new polarizers for transmissive/reflective mode LCDs. So find out today how our films can significantly increase your screen brightness. And make your display look a whole lot smarter.

For more information call 1-800-553-9215 to speak with a representative, or e-mail ostechserv@mmm.com for technical information.

3M™ Optical Enhancement Films
Brighter, wider, better.

See Us at SID '00 Booth 147

Circle no. 25

Copyright © 2000, 3M IPC. All rights reserved.

3M Innovation

By the Queen's Way

The 31st annual SID International Symposium will draw display professionals from around the world to its largest exhibition ever, technical sessions, seminars, special events, and the Display Technology Showcase - all within sight of the magnificent HMS Queen Mary.

by Ken Werner

THE Society for Information Display will hold its 31st annual International Symposium, Seminar & Exhibition (SID 2000) at the modern Long Beach Convention and Entertainment Center (LBCC) in Long Beach, California, from May 14th to 19th, 2000. The headquarters hotels are the Hyatt Regency Long Beach, which is adjacent to the LBCC, and the Westin Long Beach, about one-third of a mile from the LBCC (see map).

The annual SID International Symposium has become the leading international forum for electronic-display products, technology, systems, integration, applications, product engineering, manufacturing, testing, and human factors, and is covered by technical and business journalists from around the world.

Because of its continuous growth, each year's SID International Symposium becomes the largest exhibition of displays, display components, display-manufacturing equipment, display test-and-measurement equipment, display controllers and electronics, backlights, and display products and materials, software, services, and publications ever held in North America, and this year promises to follow the trend. The final number of exhibitors and booths is expected to comfortably exceed last year's record.

The Display Technology Showcase (DTS) will be back with an even wider variety of display and component technologies, and with an even more advanced infrastructure for supply-

ing ideal signals to each of the varied displays and more complete information about the displays to attendees. As has been true since its inception, the now-famous DTS will provide cross-technology comparisons of displays to help attendees evaluate different displays and technologies, and match technologies and applications.

There will be a seminar on the making of display measurements to be given by a representative of the U.S. National Institute of

Standards and Technology (NIST) in the DTS tent, using some of the DTS displays for measurements.

New and Expanded Seminars

Display Week will kick off with 4-hour short courses on Sunday, May 14th, and an expanded program of 90-minute seminars on Monday, May 15th. There will also be seminars on Friday, May 19th. The seminars are being taught by a remarkable collection of

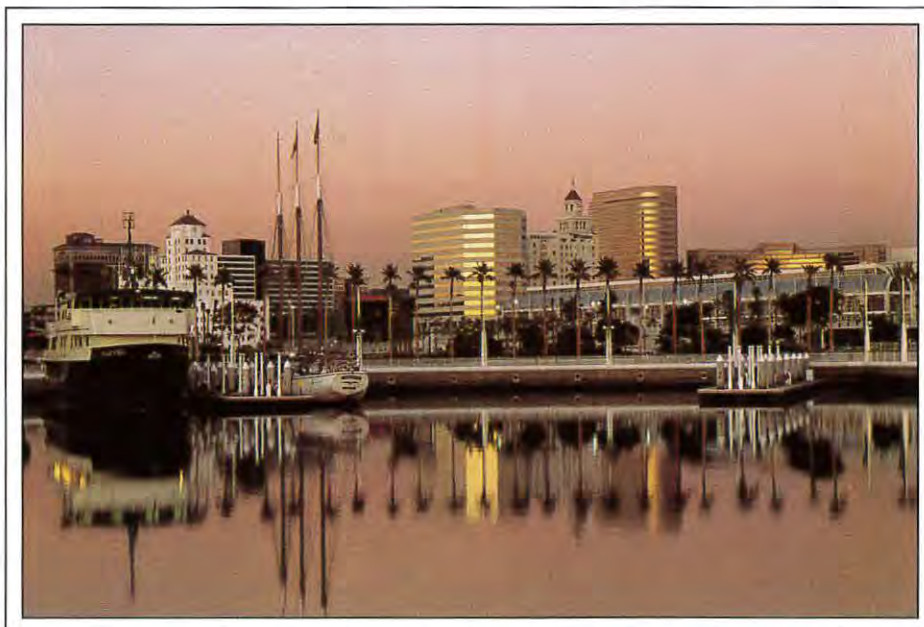

John Robinson, courtesy of the Long Beach Area Convention & Visitors Bureau

A sailing ship in Rainbow Harbor pleasingly contrasts with the Convention Center and the Long Beach skyline.

Ken Werner is the editor of Information Display Magazine.

instructors. Among them are some of the display world's most illustrious scientists, engineers, managers, and analysts. These seminars provide a unique opportunity to "sit at the feet of" knowledgeable and insightful teachers, some of whom have literally created the display landscape we know today - and are now reshaping that landscape for the future.

The introductory Monday seminar will be a display-market overview by David Mentley, Vice President of Stanford Resources. In addition to technology seminars on color plasma displays (Shigeo Mikoshiba, University of Electro-Communications, Tokyo, Japan), color in electronic displays (Lou Silverstein, VCD Sciences, Scottsdale, Arizona), OLEDs (Neil Greenham, Cambridge University, Cambridge, U.K.), CRTs (Tei Iki, Sony Electronics, San Diego, California), active-matrix LCDs (Shinji Morozumi, Prime View International, Hsinchu, Taiwan), and

supertwisted-nematic LCDs (Terry Scheffer, In Focus Systems, Hilo, Hawaii), there will be two brand-new "mini-tracks." The first, on display manufacturing, comprises three seminars: Color Plasma Manufacturing (Tsutae Shinoda, Fujitsu Laboratories, Hyogo, Japan), CRT Manufacturing (Daniel den Engelsen, Philips, The Netherlands), and Present and Future AMLCD Manufacturing (Takashi Ohta, Hitachi, Mobarra, Japan).

The second mini-track explores the hot topic of liquid-crystal-on-silicon (LCoS) microdisplays with three seminars: LCoS Overview (Chris Chinnock, Microdisplay Report, Norwalk, Connecticut), Silicon for LCoS (Ian Underwood, University of Edinburgh, U.K.), and LC Modes for LCoS (Matthias Pfeiffer, Three-Five Systems, Tempe, Arizona).

Half of the six Friday seminars will be on display integration and electronics: Monitor

AMLCD Integration (Sam Miller, ViewSonic, Walnut, California), Airborne AMLCD Integration (Kalluri Sarma and Bill Hancock, Honeywell, Phoenix, Arizona), and Digital Interfaces for Displays (Bob Myers, H-P Microdisplay Products, Loveland, Colorado). The Friday display-technology seminars will be Reflective Displays (Yoichi Taira, IBM Tokyo Research Laboratory, Yamato, Japan), Projection Displays (Patrick Vandenberghe and Arnout De Meyere, BARCO, Belgium), and Polysilicon Displays (Nobuki Ibaraki, Toshiba LCD R&D Center, Saitama, Japan).

"Our goal, which we worked hard to achieve, was to choose seminar topics and instructors that would make the Monday and Friday Seminars as exciting and rewarding as the technologies they cover," said Seminar Chair Evan Colgan (IBM Research). "We know it's sometimes hard for people to come to the Symposium a day earlier or stay a day

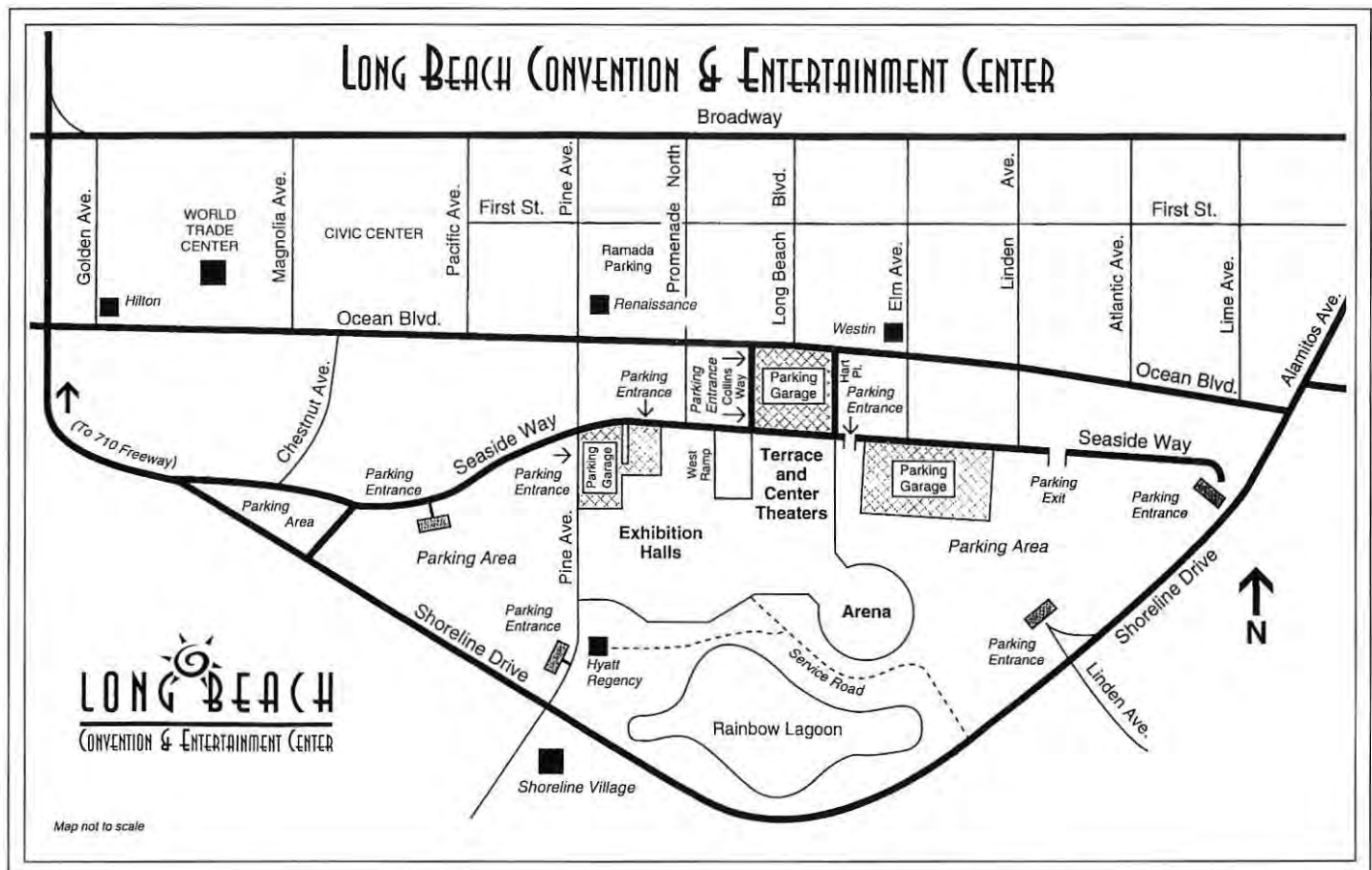

Long Beach Area Convention & Visitors Bureau

The Long Beach Convention Center is within convenient walking distance of the Pacific Ocean, several hotels, restaurants, shops, entertainment, and art galleries.

The Home of the *Queen Mary* Welcomes SID 2000

Long Beach is a varied and inviting city on the Pacific Ocean, 23 miles southwest of Los Angeles International Airport (LAX) (see www.golongbeach.org/MainMenu.htm). The city is in the midst of a \$150 million project to develop its harbor and waterfront into "the most popular waterfront destination in Southern California." Already completed are the Long Beach Aquarium of the Pacific and Rainbow Harbor. Completed in 1998, Rainbow Harbor is the centerpiece of the project and is the home of the tall ships *Californian* and *American Pride*. (The *Californian* starred in Steven Spielberg's feature film *Amistad*.) The harbor is also home to dozens of commercial vessels offering dinner cruises and tours, and is surrounded by a multi-level public esplanade. It is the first modern harbor in the U.S. to be situated within a landscaped park.

But Long Beach's most famous attraction is undoubtedly the former Cunard ocean liner *Queen Mary*, now permanently moored in Queensway Bay. The ship, substantially larger than the ill-fated *Titanic*, contains a hotel incorporating the former first-class state rooms, restaurants, bars, shops, and various attractions. Much - although, sadly, not all - of the great ship's architectural grandeur is still intact (see www.queenmary.org).

Long Beach also offers a generous supply of museums, art galleries, restaurants, bars, and shops, with free "Passport" shuttles to make navigation quick and easy. There's even an "Aquabus" water taxi from the Long Beach Convention and Entertainment Center (LBCC) to the *Queen Mary* and the nearby Russian submarine *Scorpion*. Uniformed Downtown Guides are available for advice and directions from 10 a.m. until late in the evening.

The attractive LBCC is unusual in that it contains theaters where local theatrical and musical groups perform, as well as convention facilities. It is near the Pacific Ocean and within sight of the *Queen Mary*. The Hyatt Regency Long Beach (the headquarters hotel) is adjacent to the LBCC. The Westin (alternate headquarters hotel) is a third of a mile away, and the Renaissance is 230 yards due north. The *Queen Mary* is more than a mile by land if you miss the Aquabus, but it is, obviously, a unique hotel (see the hotel reservation form at the back of this issue).

Among the area's other attractions are the Museum of Latin American Art, the Long Beach Museum of Art, and the East Village Arts District. Shoreline Village is a development of shops, restaurants, and marinas within walking distance of the LBCC, and the Pine Avenue restaurant corridor is just two blocks north.

Slightly farther afield are Naples Island, where a Venetian-style gondolier will pole you through the island's canals; Rancho Los Alamitos and Rancho Los Cerritos Historic Site, where visitors can get a taste of old California; and beautiful Santa Catalina island with its legendary Avalon Ballroom, about an hour's boat ride from Long Beach. And the well-known attractions of Los Angeles, Disneyland, and Knott's Berry Farm are certainly within reach.

later, so we wanted to make sure that the seminars would be a 'can't-miss' event, as well as a great value," Colgan said.

Invited Papers

A rich multi-track menu of technical-symposium papers, vendor exhibits, applications sessions, roundtable discussions, and special events held from Tuesday, May 16th, to Thursday, May 18th, will provide all designers, manufacturers, marketers, integrators, and end users of displays with rewarding choices, whatever their technical interests.

The technical sessions will be anchored with over 30 invited papers. Here is a representative list of authors who have been invited to speak at SID, along with their topics:

- Ultra-High-Resolution TFT-LCDs (Setsuo Keneko, NEC)
- 24-in. Wide UXGA TFT-LCD for HDTV Applications (Jun H. Souk, Samsung Electronics)
- Active-Matrix Drive for OLED Technology (Walter Riess, IBM Research)
- Softcopy Device Independence: Making Images Look the Same on Paper and on

All Screens (James Blinn, Microsoft Research)

- The Digital Revolution in Electronic Projection Display Technology (Fred Kahn, Kahn International)
- Printing Process for the Vacuum-Free Manufacture of Liquid-Crystal Cells with Plastic Substrates (Martin Randler, Universität Stuttgart)
- FLC Microdisplays for Viewfinder Applications (Mark Handschy, Displaytech, Inc.)
- Field-Sequential-Color FLC Display Using LED Backlight (Toshiaki Yoshihara, Fujitsu Labs)
- Prospects for Large-Sized TV Displays Using LCDs (Tetsuo Iwase, Sharp Corp.)
- 3-in. FED Using Carbon Nanotube Field Emitter (Sashiro Uemura, Ise Electronics Corp.)
- Developments in Multi-Neck CRTs (Shigeo Takenaka, Toshiba Corp.)

SID 2000 Technical Program Committee Chair Brian Berkeley (Apple Computer) commented: "We are emphasizing the applications and manufacturing areas in our invited papers this year, and emissive displays are coming into their own. Increasing densities, ever-larger panel sizes, and lower-cost techniques (e.g., reduced mask steps) will be presented in the active-matrix sessions. I believe the technical advances being reported this year are very significant, and the overall quality of the papers is very high.

Special Events

The President's Reception and the Awards Banquet will be held Monday evening, May 15th. (Tickets for the Awards Banquet must be purchased in advance.) The formal opening of SID 2000, along with the keynote addresses, will be on Tuesday morning, and the extremely popular exhibitor-sponsored reception will be held in the exhibit hall at the LBCC on Tuesday evening, followed by the evening panel sessions.

At the Wednesday luncheon, the Fifth Annual SID/*Information Display* Display of the Year Awards will be presented. The winners of this year's Gold Awards are Toshiba's family of low-temperature-polysilicon TFT-LCDs with integrated drivers, Sharp's 20-in. LCD television receiver, and Pixelworks' single-chip ImageProcessor™ display controllers. Silver Awards go to MicroOptical Corporation's EyeGlass™ display, Silicon



Long Beach Area Convention & Visitors Bureau

The former Cunard liner Queen Mary and the Russian submarine Scorpion are permanently moored in Queensway Bay, not far from the Convention Center.

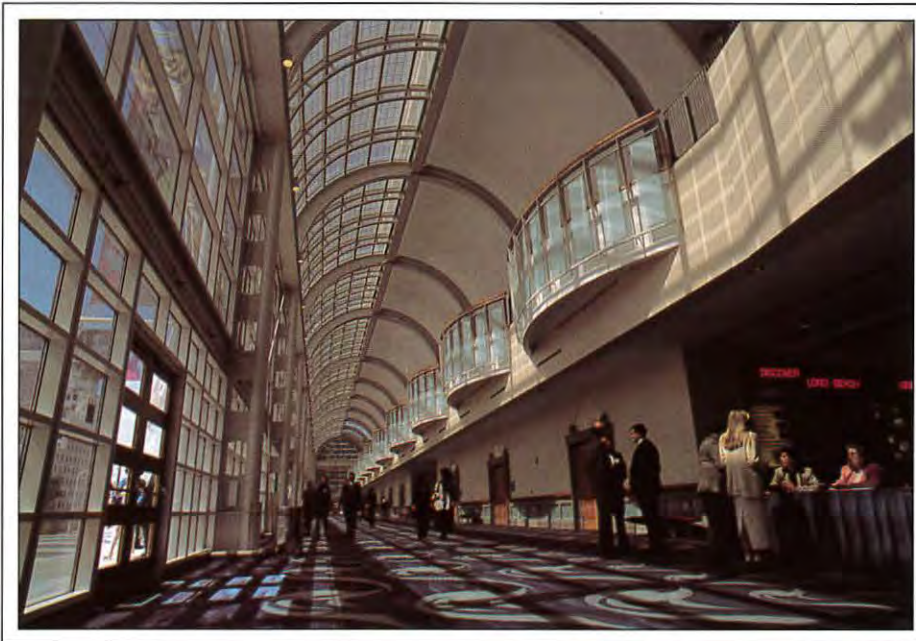

Michele and Tom Grimm, courtesy of the Long Beach Area Convention & Visitors Bureau

The inviting Long Beach Convention and Entertainment Center will be home to SID 2000 from May 14th to May 19th.

Getting to Long Beach

Long Beach is served by Los Angeles International Airport (LAX) for international and North American flights. Long Beach Airport serves general aviation and corporate aircraft.

With favorable traffic conditions, it takes about 30 minutes to drive the 23 miles from LAX to downtown Long Beach. Rental cars are readily available - this is Los Angeles, after all, the heart of the California car culture. If you won't be needing a car during the week, you can get a blue SuperShuttle van when you exit your terminal at LAX. Tell the dispatcher or a SuperShuttle driver where you want to go. There are over 200 SuperShuttle vans, and many of them serve LAX 24 hours a day. The fare is \$13 between LAX and the downtown Long Beach hotels.

If you choose to drive, ask the car-rental agent how to get to the San Diego Freeway (I-405). Take the San Diego Freeway south (toward San Diego), passing the exits for Rancho Palos Verdes and Torrance, until you reach the Long Beach Freeway (I-710). Go south on 710 until you reach Ocean Boulevard and see signs for downtown Long Beach. Bear left onto Ocean Boulevard and cross the bridge over the Los Angeles River.

When you cross the bridge, going straight ahead on Ocean Boulevard will soon bring you to the Renaissance Hotel and then the Westin Hotel, both on your left. Turning right upon crossing the bridge, onto Shoreline Drive, will soon bring you to Pine Avenue. Make a left onto Pine, and the Hyatt Regency will be on your right, followed immediately by the Long Beach Convention and Entertainment Center.

Graphics' 1600SW digital wide-screen LCD monitor, and The Digital Display Working Group's Digital Video Interface. Awards for the best papers from SID '99 will also be presented. Following SID's tradition, the luncheon speaker will be entertaining and will stretch the limits of what we usually think of as "display technology."

The special evening event, to be held on Wednesday evening, May 17th, will provide an opportunity for attendees and spouses to talk to old friends and make new ones while experiencing one of the many entertaining attractions in the Long Beach area. ■

The LCD Manufacturer Who Shares The Vision with You

GOOD VISIBILITY

Goldentek produces high-quality, reliable LCDs for a wide range of electronic products.

GREAT SERVICE

Goldentek provides advanced quality with competitive prices, timely delivery and comprehensive technical consultations.

GROWING PROSPECT

With 9 years of LCD production experience, Goldentek is the rising sun in the world of LCDs with the best equipment and facilities, together with the top-ranking engineers.

- TN, STN, FSTN, Custom, Standard, LCD, LCM.
- Extended temperature ranges, low power, high contrast.
- COB, COG, TCP, E/L, LED, CCFL backlight.

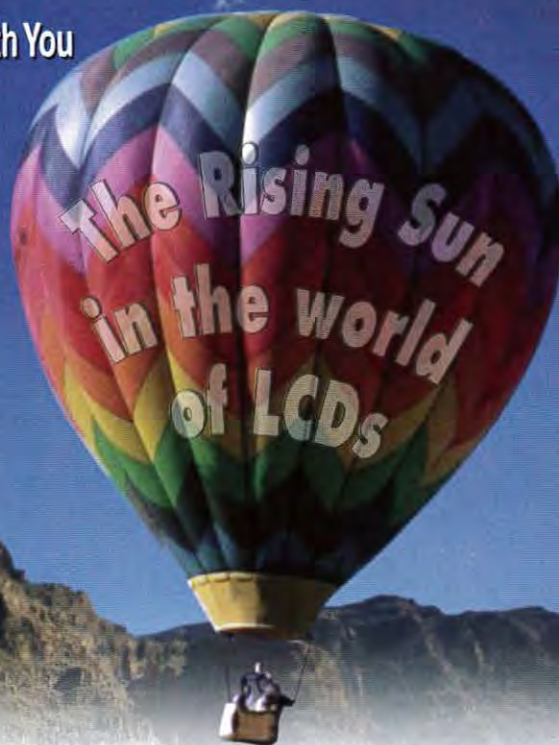

Goldentek Display America, Inc.

2115 W. Crescent Avenue, Suite 251, Anaheim, CA 92801 (U.S.A.)
TEL: 714-774-4653 FAX: 714-774-4659
E-mail: goldentek@aol.com
www.goldentek.com.tw



The LCD Specialist

Circle no. 26

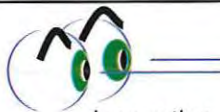

SharpEye™ Inspection Station

Inspection of Small Flat Panel Display Technologies

The **SharpEye™** small flat panel display inspection station is designed for the inspection of LCoS, OLED, MEM, EL, LTPS, FED, LCD and other emerging technologies.

The **SharpEye™** station can be configured to inspect all industry display formats such as **QVGA, VGA, SVGA, XGA, SXGA, SXGA+, UXGA and HDTV.**

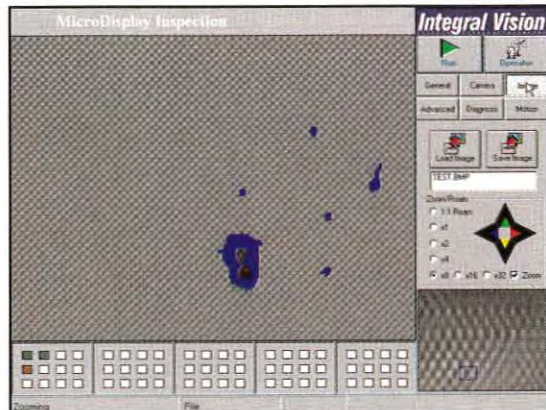

SharpEye™ offers system configurations to meet the exact production inspection requirements of the display manufacturer. Inspection parameters for defect resolution and classification, cycle time, data reporting, and automation are considered with each customer's application requirements.

For more product information visit our web site at www.iv-usa.com

Integral Vision
Simply **POWERFUL** Vision Solutions

USA: Tel. +1(248) 471-2660 Fax. +1(248) 615-2971 Email. sales@iv-usa.com
Europe: Tel. +44 1234-843345 Fax. +44 1234-843390 Email. sales@integral-vision.co.uk
Japan: Tel. +81 (052) 232-0727 Fax. +81 (052) 232-0729 Email. kondoy@marinet.or.jp

The Total Solution to Accurate CRT/FPD Measurement.

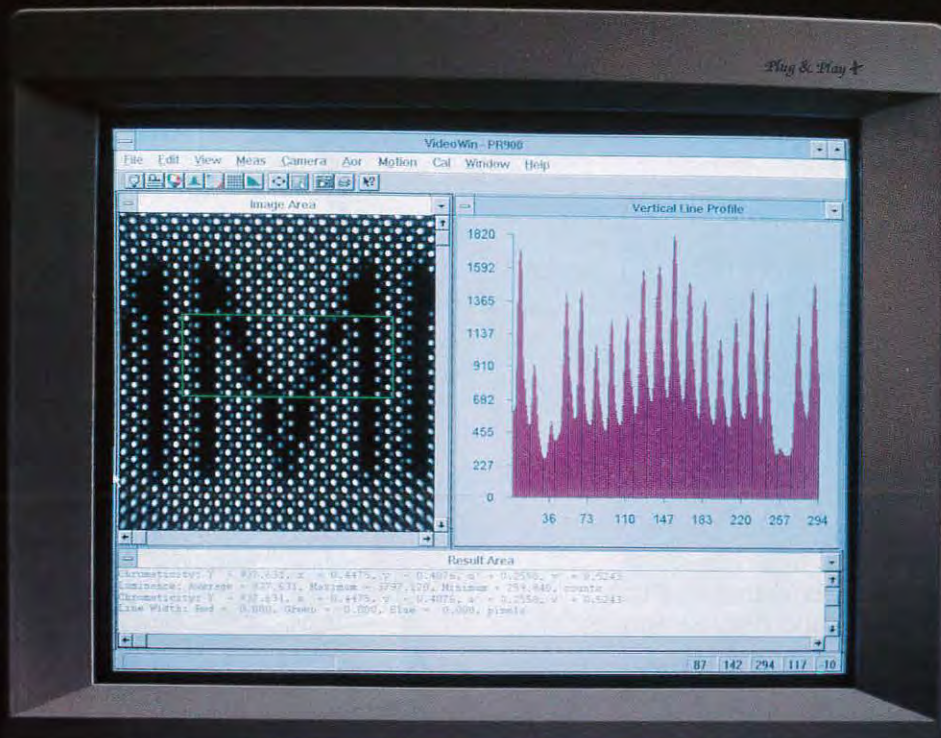

For more than 50 years Photo Research Inc. has provided solutions to measurement needs in all sectors of the information display industry. We are acknowledged experts for NIST traceable measurements of CRT's, LCD's, FPD's, LED and Night Vision displays.

If lack of versatility and low light sensitivity for luminance measurements is the problem, the PR-880 fully automated photometer is the solution. Using through-the-lens Pritchard optics, the PR-880 makes accurate, automatic measurements of displays – just push a button!

If color is the question, the PR-650 SpectraColorimeter is the answer. The only true hand-held spectroradiometer in the world, the PR-650 measures displays spectrally, guaranteeing precise color results regardless of the spectral signature of the source.

Combining state-of-the-art CCD technology and Photo Research's proven measurement expertise, the PR-900 Video Photometer is the industry standard for testing for compliance to the ISO's demanding ergonomic requirements. The PR-900 is the instrument of choice whenever accurate photometric and spatial measurements of displays are a must.

Call us today for a free full color CIE chromaticity diagram!

See Us at SID '00 Booth 201

Circle no. 28

"The Industry Standard for Display Measurements."

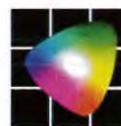

PHOTO RESEARCH.INC

9731 Topanga Canyon Place
Chatsworth, CA 91311-4135 USA
Tel: 818/341-5151 • Fax: 818/341-7070
<http://www.photoresearch.com>

SID Conference Calendar

Next Show!

International Symposium, Seminar & Exhibition (SID '00)

JOIN US IN LONG BEACH TO SEE AND HEAR WHAT'S NEW IN DISPLAY TECHNOLOGY.

- The Technical Program will consist of over 180 original and invited papers with 60 more in a Poster Session, all organized in six parallel tracks:
 - AMLCDs and Display Manufacturing
 - Applications and LC Technology
 - CRTs and Emissive Displays
 - Applied Vision, Human Factors, Display Measurement, and Display Electronics
 - Projection Displays and Display Systems
- The Seminar Program will once again draw on industry leaders for three days dedicated to short courses, technology overviews, and display applications.
- Over 250 vendors will demonstrate the latest in displays, components, and equipment
- Evening Panel Discussions, an Exhibitor Reception, a Conference Luncheon, and an evening Social Event will complement the technical program.

14 ⁰⁰

MAY

SID '00
LONG BEACH, CALIFORNIA
MAY 14-19, 2000

- SID's MAJOR ANNUAL EVENT
- An International Symposium, Seminar, and Exhibition - Featuring:
 - Technical Sessions - Poster Session
 - Author Interviews - Evening Panels
 - Short Courses - Applications Seminars
 - Technical Seminars - Applications Sessions
 - Product Exhibits - Display Technology Showcase

25 ⁰⁰

SEPTEMBER

20th International Display Research Conference (IDRC '00)

PALM BEACH, FLORIDA
SEPTEMBER 25-28, 2000

- An international conference on display research and development aspects of:
 - Display Fundamentals, Display Devices
 - Hard Copy & Storage, Input Systems
 - Integrated Devices and Applications
 - Image and Signal Processing
 - Color Perception, Human Factors

For additional information:

Dee Dumont
Society for Information Display
31 East Julian Street
San Jose, CA 95112
408/977-1013, fax - 1531
www.sid.org

6 ⁰⁰

NOVEMBER

Sixth International Conference on the Science and Technology of Display Phosphors

SAN DIEGO, CALIFORNIA
NOVEMBER 6-8, 2000

- An international conference on the future prospects of phosphors for:
 - OLEDs - ELDs - FEDs
 - CRTs - Plasma Displays
 - PL Devices - LC Backlights

14 ⁰⁰

NOVEMBER

8th Color Imaging Conference: Color Science, Engineering, Systems & Applications

SCOTTSDALE, ARIZONA
NOVEMBER 14-17, 2000

- An international multidisciplinary forum for dialogue on:
 - Creation and capture of Color Images
 - Color Image reproduction and interchange
 - Co-sponsored with IS&T

SID

Since 1962, a professional worldwide interdisciplinary society committed to the advancement of information display.

TCO
VESA
WIDL

Are you CONFUSED by TESTING STANDARDS?

ISO

Let Microvision's display test systems
simplify them for you with **AUTOMATIC** test suites!

Microvision's SS200 series of display test equipment offers fully automatic test suites for flat panels, CRTs, projection & cockpit displays, in monochrome or color. One click of the mouse and your test suite is automatically initiated, performing fast & accurate measurements in accordance with ISO (9241 parts 3,7 & 8 and 13406-2), TCO (95 &99), NIDL and VESA (FPDM) specifications. Or you can develop your own test sequence with Microvision's proprietary MATL software. With the SS200 family, you can quickly interchange between CRT and flat panel testing. And the system is portable and compact, fitting easily into any test area.

Used by testing laboratories
world-wide.



Visit our Website at:
www.microvsn.com

MICROVISION

550 High Street, Auburn, CA 95603
Tel: (530)888-8344 * (800) 931-3188
Fax: (530)888-8349
Email: sales@microvsn.com

Circle no. 29

See Us at SID '00 Booth 215

Swing the odds in your favor

Go for quality LCD modules go for **SOLOMON**



SOLOMON www.solomonlcm.com.tw

SOLOMON Technology Corp. LCM Div.
Chang Tai Street, Hsiao Kang Dist. TW-812 Kaohsiung, Taiwan ROC
TEL: 886-7-8721787 FAX: 886-7-8721786
E-mail: jl@solomonlcm.com.tw

SOLOMON Technology (USA) Corp. LCM Div.
21038 Commerce Pointe Dr. Walnut, CA 91789, USA
TEL: 909-468-3732 Ext. 3038/3039 FAX: 909-869-6268
E-mail: jbutler@solomonusa.com



See Us at SID '00 Booth 457

Circle no. 30

display continuum

continued from page 4

Only one time in my career, while working for DuPont, was I required to abide by a corporate "clean desk" policy. This policy is in place for quite good and logical reasons as a

way to protect a company's confidential information from after-hours prying eyes. I found that the only way I could meet the requirements of this policy was to keep a deep

drawer empty and every night to create a crisscross stack of all the items on my desk and carefully lay it into this drawer. Then each morning I would reverse the procedure so that I would know what I needed to work on that day. Why couldn't I just use file folders that stayed in a desk drawer, a file cabinet, or my PC to keep track of everything? And with the recent advances in computer technology, why don't I do it now? Well, at long last, I think I may have stumbled onto the answer.

Prof. Jay Brand, a former psychology professor who now works for the office-furniture manufacturer Haworth, Inc., has provided an explanation that makes me feel ever so much better. This explanation came to me by way of an article in the *Seattle Post-Intelligencer* authored by Carol Smith. As I began to read, I immediately noted how similar her observations and concerns were to mine. Well, of course, don't we always appreciate wisdom and insight that agrees with our own?

What Prof. Brand, who is now called a "cognitive engineer," has concluded is that all of us have limited capacity in our short-term memories. Good insight, Prof. Brand! It's good to know that I am not the only one who can't handle a list of items greater than two without writing them down. Perhaps my limited-capacity CCD-like short-term memory, in which the third or fourth items seem to fall out the back end whenever a new one comes in, is not so atypical after all. According to Prof. Brand, "Since most people are doing seven things at once, they tax the capacity of their working memory almost immediately." Therefore, information placed into our external environment is known as a "cognitive artifact." This allows us to off-load some information from our own overtaxed working memory. "It expands a person's capacity to think. You're using the environment to think as well." I think I am beginning to really like this Prof. Brand!

The companies that require clean-desk policies are in essence giving their workers "environmental lobotomies" or at least requiring them to re-create their working environments at the start of each day. "Workers in such environments can sometimes feel like they spend more time getting organized than working on actual projects." As with all good things, one can, however, carry this to the extreme. If the piles of papers no longer have meaning and are not providing visual cues,

First in PC...

SID '00
Booth 245

Video Test Generators

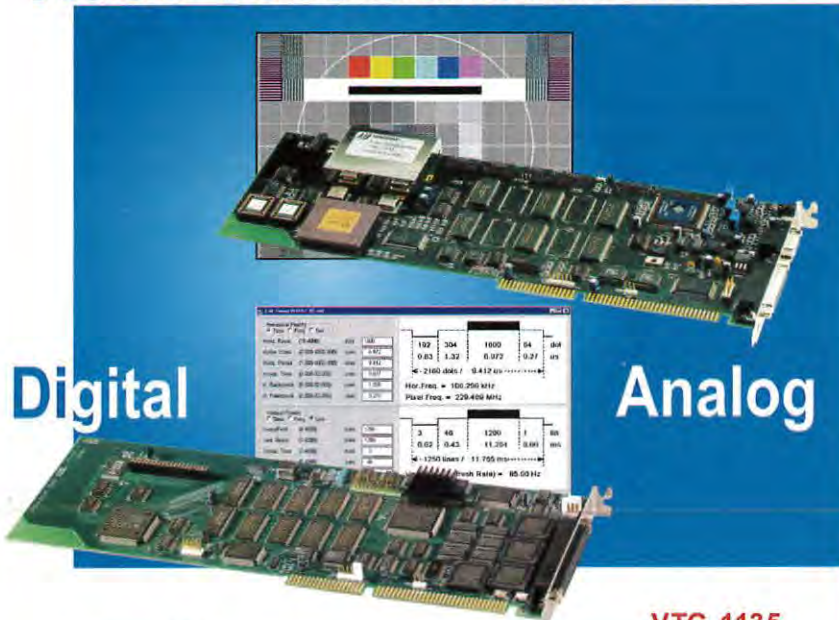

VTG-1108

- 80 MHz Double Pixel Clock for 160MHz Pixel Frequency
- 2k x 2k x 8bit Colours out of 16.7 million
- Scrolling colours or bitmaps for test pattern animation
- External Interface Adapters for LVDS, TMDS, PanelLink, DVI, RGB, Parallel-TTL interfaces and for future solutions

VTG-1135

VTG-1250 VTG-1300

- Pixel frequency up to 300 MHz
- Resolutions over 2048 x 1536
- DLL control with WinVTG.exe or user's own software (Basic, C++)
- Unlimited number of permanent patterns, timings, colours, palettes, signal formats and sequences

Distribution network

GERMANY: Meinhardt Electronic, +49 2129 4461
GERMANY: TL-Elektronik, +49 89 329 4490
HUNGARY: DEXON Systems, +36 1 335 7162
JAPAN: ARGO, +81 6 339 3366

KOREA: WE Corporation, +82 2 585 8253
TAIWAN: ACCESS Technology, +886 2 2299 6272
UK: Ginsbury, +44 1634 298900
USA: TEAM Systems, +1 408 720 8877

 **UNIGRAF**
ISO 9001 CERTIFICATED FIRM

UNIGRAF Oy, Ruukintie 3
FIN-02320 Espoo, Finland
Tel. +358 (0)9 859 550
Fax +358 (0)9 802 6699
Email: sales@unigraf.fi
http://www.unigraf.fi

See Us at SID '00 Booth 243

Circle no. 31

then they become just that – piles of meaningless stuff. However, while organized in some coherent and frequently updated way, there is real benefit to be gained here. I think I can be sufficiently honest with myself to say that mostly I fit into this well-organized category. In fact, while writing this column I did a quick survey. I passed the test.

I am sure that most of you reading this column will agree with and accept this explanation with enthusiasm as great as mine. I know you will because I have seen many of your desks. However, as display engineers and scientists, there is something here about which we should be concerned. What does this say about using our computer screens to display our important information and to keep it organized? It says, I think, that current display products, which provide only a limited active display area, are going to continue to be significantly less efficient than the cluttered-desktop method. Computer folders and the files they contain provide minimal visual cues compared to a “real” desktop. The process of browsing is also much slower on the computer. If I’m not sure what a file or a document contains, I have to click on it, open it, read it, and then close it again. I have to do this for each item that I want to see. On my desktop, using the traditional manual method, I can visually scan and retrieve these items in a fraction of the time. Furthermore, on the computer, when I close a file or a folder, the visual cues once again disappear.

Some of you more dedicated computer users will tell me that if I just took the time to create a special folder for all my current activities and created links to these folders containing the information on those clients, I could keep that screen active and always be able to overview what I needed to do next. But why do I want to take the time to do that when I can do it faster by just putting a piece of paper or a “real” folder on my desktop in a fraction of the time? What advantage will I gain by doing it on the computer? The result would be a far slower process for every one of the steps of acquisition, access, updating, and deletion. Would I do better if I had a larger computer-monitor screen? Only slightly. The real problem seems to be in how to provide the necessary visual cues and how to create the equivalent convenience of the desktop. Some traditionalists among us may even pose the deeper philosophical question more concisely: “Why bother?” Is it necessary or even

desirable to try to endow computers with the power to replace some or all of these current behaviors and activities? Let’s test this premise.

As a thought experiment, suppose you could do the following. Suppose you could have a flat-panel display of 40–50 in. on the diagonal and very high resolution (perhaps

Show Your True Color

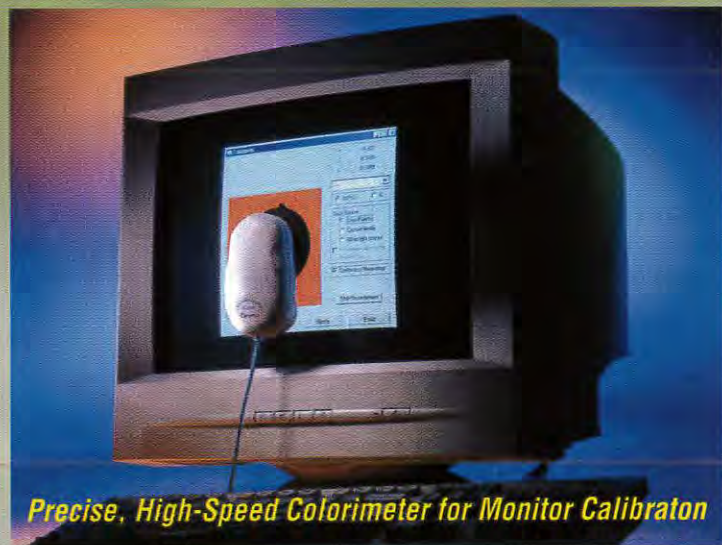

Precise, High-Speed Colorimeter for Monitor Calibration

Chroma 7130 Mini colorimeter

The *Chroma 7130 mini colorimeter* is a *compact CIE-based colorimeter*. It is designed with a *built-in processor* for fast and accurate measurement data. It offers a variety of measurement functions like *chromaticity luminance* and *color temperature* for calibration, characterization, and control of color monitors

Chroma
CHROMA ATE INC.

CHROMA ATE INC.
43, Wu-Chuan Road, Wu-Ku Ind. Park,
Wu-Ku, Taipei Hsien, Taiwan, R.O.C.
Tel : +886-2-2298-3855 ext.8209
Fax : +886-2-2298-3596
E-mail: chroma@chroma.com.tw

CHROMA ATE INC. (U.S.A.)
15279 Alton Parkway, Ste. 400
Irvine, CA 92618
Tel : +1-949-788-0822
Fax : +1-949-788-0608
Toll Free: 1-800-478-2026

EUROPE B.V.
Max Planckstraat 4
6716 BE Ede, The Netherlands
Tel : +31-318-648282
Fax : +31-318-648288

<http://www.chromaate.com.tw>

Circle no. 32

display continuum

3000 × 4000 pixels) conveniently located near your computer. This could be the primary display or a display supplemental to the one used for current processing activities. On this large display, all of your important stored information would be shown in a pictorial format similar to the view of looking at a desktop from a sitting position, *i.e.*, a 2-D display with a computer-generated appearance of perspective. Now, suppose you could point with your finger to a particular stack of information (documents) on this virtual desktop and that document or memo would instantly appear in an unused part of the display screen. And if you moved your finger up or down this virtual stack, other pages would similarly be retrieved and displayed. If you wanted to store something, all you would have to do is "draw" a square on the screen with your finger and the material would be placed in that location. Or if you pointed to a document and

then to a location, it would be placed there. For more involved instructions, the computer would accept simple verbal commands.

Using this approach, we have now not only provided all the visual cues that can be found on a traditional desktop, we can actually find and retrieve information *faster* in this "knowledge space" than is possible with the manual search method.

Once we develop such a display, the days of the clicking mouse will be numbered. What a grand challenge this could become – perhaps as important as the development of the shadow-mask CRT for color television. Such a display would create a picture-window view for the rapidly evolving Information Society to use instead of the comparative peepholes that we have today.

We display engineers hold more of the future of the Internet and the World Wide Web in our hands than most people yet real-

ize. We may need to help promote this awareness so that adequate investment becomes available to develop the necessary new display technologies. Over the last twenty years, computer processing power and information storage and manipulation capabilities have progressed faster than improvements in displays. As the recognition grows that displays are now limiting the further development and usefulness of various information appliances, the demands on the display community will increase. This will lead to great opportunities for many of us – balanced with equally great challenges.

Are you ready to start work on the 3000 × 4000-pixel 1.2-m *knowledge-space* display? I am. To get this project under way, you can contact me by e-mail at silzars@attglobal.net, by phone at 425/557-8850, by fax at 425/557-8983, or by high-resolution hardcopy at 22513 S.E. 47th Place, Issaquah, WA 98029. ■

Simplicity with Power.



That's the Klein VPG250.

- | | yes | no |
|--|-------------------------------------|--------------------------|
| • Programmable custom patterns? | <input checked="" type="checkbox"/> | <input type="checkbox"/> |
| • Displays and runs DDC 1/2B from test unit? | <input checked="" type="checkbox"/> | <input type="checkbox"/> |
| • Programmable timings? | <input checked="" type="checkbox"/> | <input type="checkbox"/> |
| • Pre-loaded VESA timings? | <input checked="" type="checkbox"/> | <input type="checkbox"/> |
| • Displays xyY from colorimeter accessory? | <input checked="" type="checkbox"/> | <input type="checkbox"/> |
| • Helps test work flow smoother? | <input checked="" type="checkbox"/> | <input type="checkbox"/> |

Call today for a FREE five-day trial!

KLEIN Instruments
Corporation

2236 SE Belmont St, Portland, OR 97214 USA
tel 503.245.1012 fax 503.245.8166
sales@kleininc.com www.kleininc.com

Circle no. 33

Save 90% of Original Cost

750mm World Class Sputter Coating Systems

- Double Sided • Vertical In-Line
- DC and RF • Up to 6 double side 750mm targets • Automated for production needs
- Good condition • Professional De-Install
- Documentation • Ready to ship now

Ulvac SPC-400

- Cryo Pumps • Rack & Pinion Drive
- PhD Process Devel. and Ulvac-Trained
- Installation Consultants • Qty. 2

www.lasermotion.com/vac.html

LMDC Laser & Motion
Development Co.

3101 Whipple Road, Union City, CA 94587

510-429-1060 Fax-429-1065

Circle no. 34

DPT. A one stop shop for all your LCD and notebook requirements.

- * Turnkey module & hinge-up LCD repair
- * Warranty disposition
- * LCD monitor repair / refurbishment
- * LCD module customization
- * Notebook repair
- * Component level motherboard repair

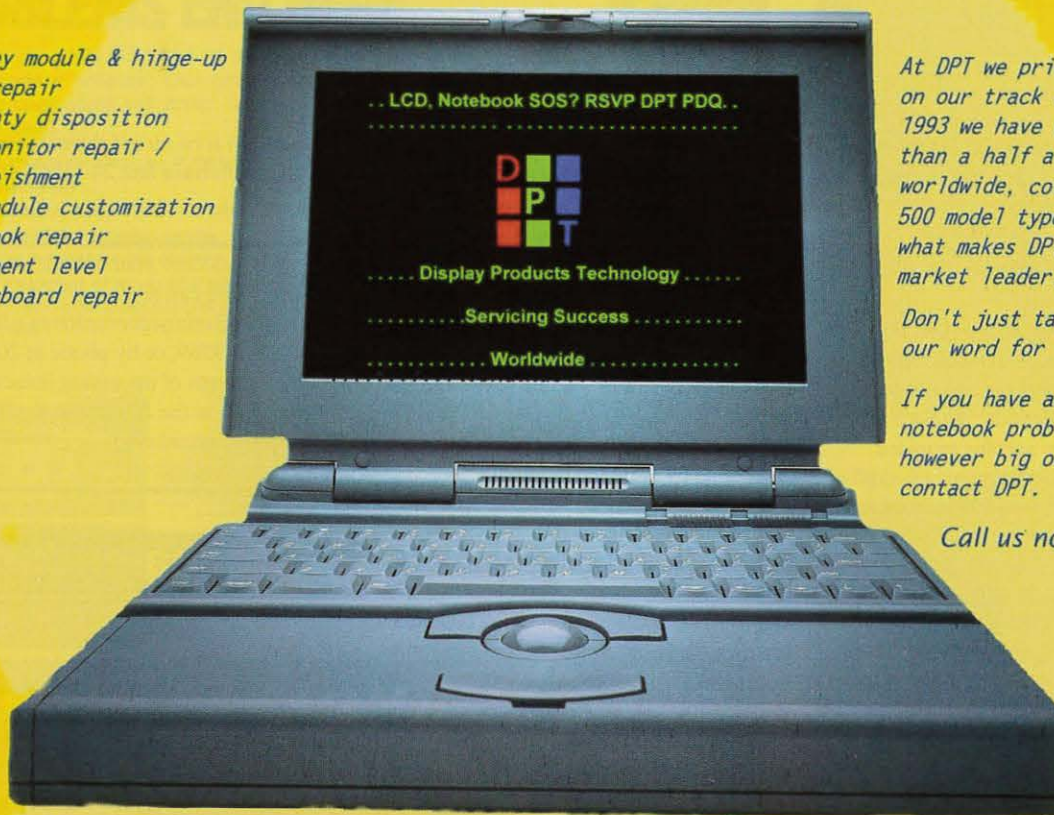

At DPT we pride ourselves on our track record. Since 1993 we have repaired more than a half a million units worldwide, covering over 500 model types. That's what makes DPT the market leader.

Don't just take our word for it.

If you have an LCD or notebook problem, however big or small, contact DPT.

Call us now.

FOR MORE INFORMATION CONTACT CHRIS PATON:

Tel: +44 (0) 1355 239199

Email: cpaton@dpt-ltd.co.uk

Fax: +44 (0) 1355 241190

Circle no. 35



Electronic Information Displays
The Displays Technology Show

Europe's premier displays exhibition and
SID conference is now at London's
premier exhibition venue.

Beat the rush ... Call +44 (0)1822 614671 or
visit www.eid.co.uk to reserve your space.

EXCEL

LONDON E16 1XL

21 - 23
NOVEMBER
2000



continued from page 2

working with equipment and materials suppliers, TFT-LCD producers, and notebook-PC producers:

Q3 '99, 17%; Q4 '99, 15%; Q1 '00, 10%; Q2 '00, 5%; Q3 '00, 0%; Q4 '00, -1%

The forecast for Q3 '00 and Q4 '00 is virtual equilibrium, which still results in a shortage because there can not be perfect panel-size allocation. However, in 2001 we expect the surplus to widen when the nearly \$7 billion in cumulative capital spending from 1999 to 2001 will cause TFT-LCD capacity to double from Q3 '99 to Q3 '01. The dramatic increase in TFT-LCD capacity will cause prices to fall by more than 15% per quarter from the second half of 2001 in the price-sensitive LCD-monitor market in order to keep the surplus to 5%. The dramatic price reductions will be followed by a slowdown in capital spending, which will result in another shortage, followed by price increases and additional investment as the crystal cycle repeats itself.

A DYA-Inspired Monitor

Since we are talking this month, at least in part, about the growing market for LCD monitors, let me tell you a little story about Madhu Reddy, founder of U.S. Electronics (5730 Duluth St., Minneapolis, Minnesota, telephone 612/591-2605). Reddy was having discussions with Japanese monitor maker Totoku – a company that used to make monitors for ViewSonic before the latter company moved its production to Taiwan – about producing a line of TFT-LCD monitors for the professional market in North America that U.S. Electronics would distribute.

When Reddy saw the results of the 1998 Display of the Year Awards, he convinced Totoku to incorporate the Silver-Award-winning Fujitsu multi-domain vertical-alignment Fujitsu TFT-LCD in the 15-in. monitor.

Reddy recently sent *ID* an evaluation unit of this model, the Totoku CV511T autoscanner display. The analog-interface unit is indeed equipped for the professional market, with two 15-pin input jacks (for two independent VGA-family inputs) and RCA jacks for composite video (software-switchable between NTSC and PAL) and monaural audio. There is an unpowered USB hub in the base with one upstream and four downstream ports. The base is heavy and stable, and the screen

rotates smoothly about the horizontal axis. There is no adjustment for elevation.

Used at its native XGA screen resolution, the monitor is very sharp and stable. The viewing angle is wide, the 18-bit color is subjectively well-saturated, and, with 200 cd/m², the monitor is more than adequately bright. The monitor will display non-native formats in fixed (pixel for pixel on a portion of the screen) or variable (scaling to fill the screen) mode. In both modes, pitch and phase are adjustable over a wide range. Despite the adjustments, VGA showed scaling artifacts on text of the “quantum noise” type that couldn’t be tuned out. SVGA and Apple 1152 x 864 inputs also had artifacts that exhibited as a slight periodic defocusing of the characters, but these did not “flutter” as the quantum-noise artifact does. The monitor was entirely usable with these inputs and serviceable with VGA. But where this monitor shines is at its native XGA resolution.

The Fujitsu panel has a total response time of about 25 msec, which should make it entirely suitable as a video monitor. We hooked the monitor to the video and audio out jacks of an ancient 19-in. CRT-based TV receiver that was made before black-matrix tubes were commonplace. With the help of the pitch control, the NTSC signal readily filled the CV511T’s screen. Not surprisingly, the 200 nits that looked so bright in a PC monitor suddenly did not look bright in a side-by-side comparison with the old CRT. But text and still images looked sharper and blacks were blacker.

A reduction in the definition of moving objects – such as the wrinkles around Tom Brokaw’s mouth on the evening news – was noticeable in a side-by-side comparison, but would probably not be highly objectionable in most applications.

The SID Display Technology CD-ROM test disk verified the good saturated colors and nearly photographic rendition of 24-bit photographic images. But the 18-bit drivers did not distinguish low-lying (nearly black) gray shades in test patterns. Pixel tracking and video-amplifier bandwidth were not perfect, but did not seem to create visible problems in standard applications and viewing of high-definition images.

This is a very attractive computer and video monitor that uses a state-of-the-art TFT-LCD and is mechanically solid. We will return it to U.S. Electronics with regret. Even so,

wouldn’t it be nice if the next version had a digital interface and 24-bit drivers?

— KIW

We welcome your comments and suggestions. You can reach me by e-mail at kwerner@nutmegconsultants.com, by fax at 203/855-9769, or by phone at 203/853-7069. The contents of upcoming issues of *ID* are available on the *ID* page at the SID Web site (<http://www.sid.org>).

calendar

Workshop on Metrology and Modeling of Color and Appearance. Sponsored by NIST, U.S. Dept. of Commerce. Contact: Teresa Vicente, NIST; telephone 301/975-3883, fax 301/948-2067, e-mail: teresa-vicente@nist.gov.

Mar. 29–30, 2000 Gaithersburg, MD

2000 SID International Symposium, Seminar & Exhibition (SID '00). Sponsored by the Society for Information Display. Contact: Mark Goldfarb, Palisades Institute for Research Services, Inc., 411 Lafayette Street, 2nd Floor, New York, NY 10003; 212/460-8090 x202, fax -5460, e-mail: mgoldfar@newyork.palisades.org.

May 14–19, 2000 Long Beach, CA

The First International Display Manufacturing Conference & Exhibition (IDMC 2000) and Vendor Exhibition (FPD Expo 2000). Sponsored by the SID Korea Chapter and Korea Information Display Society. Contact: Prof. S. Lim, Secretary General; telephone +82-417-550-3542, fax -3592, e-mail: limsk@ns.dankook.ac.kr.

Sept. 5–7, 2000 Seoul, Korea

Twentieth International Display Research Conference (IDRC '00). Sponsored by the Society for Information Display. Contact: Ralph Nadell, Palisades Institute for Research Services, Inc., 411 Lafayette Street, 2nd Floor, New York, NY 10003; 212/460-8090 x203, fax -5460, e-mail: rnadell@newyork.palisades.org.

Sept. 25–29, 2000 Palm Beach, FL

Eighth Color Imaging Conference: Color Science, Engineering Systems & Applications.

Sponsored by IS&T and the Society for Information Display. Contact: Dee Dumont, SID HQ, 31 East Julian St., San Jose, CA 95112; 408/977-1013, fax -1531, e-mail: office@sid.org.

Nov. 14–17, 2000 Scottsdale, AZ

YOUR MAGNETIC SHIELDING PROBLEMS END HERE

Save tooling costs—Ad-Vance already owns tooling for most standard shields. Our problem solving magnetic shielding specialists will adapt or custom design exactly what you need.

- Magnetic shields for 324 types of PM tubes
- AD-MU sheet stock
- AD-MU protective cases assure full fidelity of valuable taped data
- Helpful engineering & design service
- Painstaking in-house quality control.

Now—4 decades of magnetic shielding leadership. Your magnetic shielding problems end here at Ad-Vance.



AD-MU foils cut, wrap easily, quickly



AD-VANCE Magnetics' 20-page Procurement Catalog gives major designing/procuring guidelines. The 64-page Engineering Catalog contains valuable technical engineering information about the entire magnetic shielding field. Yours for the asking.



Completely modern mfg. facilities



AD-VANCE MAGNETICS, INC.



P.O. Box 69 • 625 Monroe Street • Rochester, Indiana 46975
 (219) 223-3158 • FAX (219) 223-2524
 E-Mail: sales@advancemag.com
 Web Home Page: <http://www.advancemag.com>

See Us at SID '00 Booth 226

Circle no. 38



1. Place.

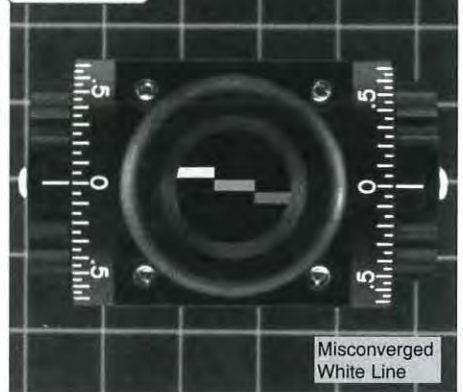

2. Measure.

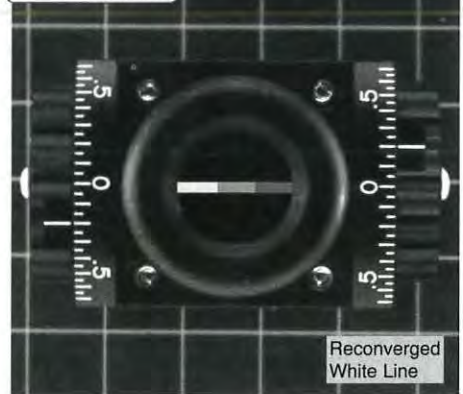

Call For A Sample And Our New Literature

Light Shaping Diffusers®

- High transmission efficiency (up to 92%)
- Controlled light distribution (0.2° to 95°)
- Homogenized light
- Mass produced technology

Poc Physical Optics Corporation®

Ph: (310) 320-3088 Fax: (310) 320-8067 Web: www.poc.com

Manufactured under U.S. patent nos. 5,365,354; 5,534,386; 5,609,939; 5,631,754; 5,629,996 and other patents pending.

See Us at SID '00 Booth 638

Circle no. 39

KLEIN
 Instruments Corporation

Contact us now at
Klein Instruments
 Portland, OR USA
 ph (503) 245-1012
 fax (503) 245-8166
www.kleininc.com

Circle no. 37

Precision

Westar's FPD Performance Measurement Systems give you something unique -- precision and flexibility. Westar's FPM Systems provide photometric and colorimetric measurements, real-time reporting of test results, increased test and analysis productivity, and performs standard tests as well as your own custom tests.

Westar's FPD Performance Measurement System

- Tests displays up to 54" automatically.
- Tests for luminance, chrominance, contrast & viewing angle performance...and more!
- Uses popular sensors, such as PR, Minolta, and Topcon.

Performs VESA, TCO '99 and ISO 13406-2 tests!

Powerful ViewPoint™ software integrates sensors, motion control, analysis, and reporting functions. It also includes a wide variety of fully integrated display interfaces!



FREE Video and CD

For more information on Westar's revolutionary new systems, call today for our **FREE** video and CD.

Copyright © 2000, Westar Corporation
Trademarks are property of their respective owners. Patents Pending.

See Us at SID '00 Booth 424

Flexibility



Products for better displays.™

USA: Westar Corp., 314-298-8748 ext.286
Japan: Kyokuto Boeki Kaisha, Ltd., 03-3244-3795
Korea: Truco, Inc., 02-3465-2004
Taiwan: Advanced Team Enterprise Co., Ltd., 02-27035466
China: Advanced Team Technology Service, 769-632-6399
Europe: Ginsbury Electronics, Ltd., +44 (0) 1634-298900

www.westar.com

Circle no. 40

DURALAN II™

High Performance
Windows/Lenses/Filters...
Custom Fabricated to Meet
Your Design Requirements

Features Include:

- ▶ EMI/RFI and ESD Protection
- ▶ Excellent Clarity
- ▶ Superior Contrast Enhancement
- ▶ Unique Antiglare Properties
- ▶ Scratch and Chemical Resistance
- ▶ Custom Graphics
- ▶ "Privacy" Windows
- ▶ Custom Fabrication

SILVER CLOUD

MANUFACTURING CO.
GRAPHICS AND ELECTRONICS

For additional information call 856/825-8900,
fax 856/825-8969, or visit our web site at
www.silver-cloud.com

Transforming Design Concepts Into Reality

See Us at SID '00 Booth 358

Circle no. 41

TROUBLESHOOTING MONITORS?

15 Day Evaluation Period



Every video pattern you need
for complete monitor
troubleshooting and alignment.

only
\$995

from
Xtronix®

*The Troubleshooter
Model 3030*

• 200KHz Horizontal Freq.

• DDC Test

• Auto Configuration Setup

Optional Color Measurement



Xtronix Corporation
3150 Clinton Court • Norcross, GA 30071
tel: 770.495.4881
www.xtronix.com

See Us at SID '00 Booth 934

Circle no. 36

Large Area Hard Masks.

Substrate sizes up to 32"x 24"
(800 mm x 600 mm).

Precision and resolution in the
micron range.

Highest Accuracy.

Excellent pattern and contour
definition.

Manufacture with Direct Write Laser
from customer CAD data.

Speedy times of delivery.

Highly skilled CAD staff.

Materials: Iron oxide and Chrome.

Visit us at the SID 2000 – booth 256

IMT Masken und Teillungen AG
Im Langacher, Greifensee
P. O. Box, CH-8606 Nänikon
Switzerland
Phone +41 1 943 19 00
Fax +41 1 943 19 01
E-Mail imtadmin@imtag.ch
www.imtag.ch

IMT
PRECISION ON GLASS

See Us at SID '00 Booth 256

Circle no. 42

SID 2000 HOTEL LOCATOR

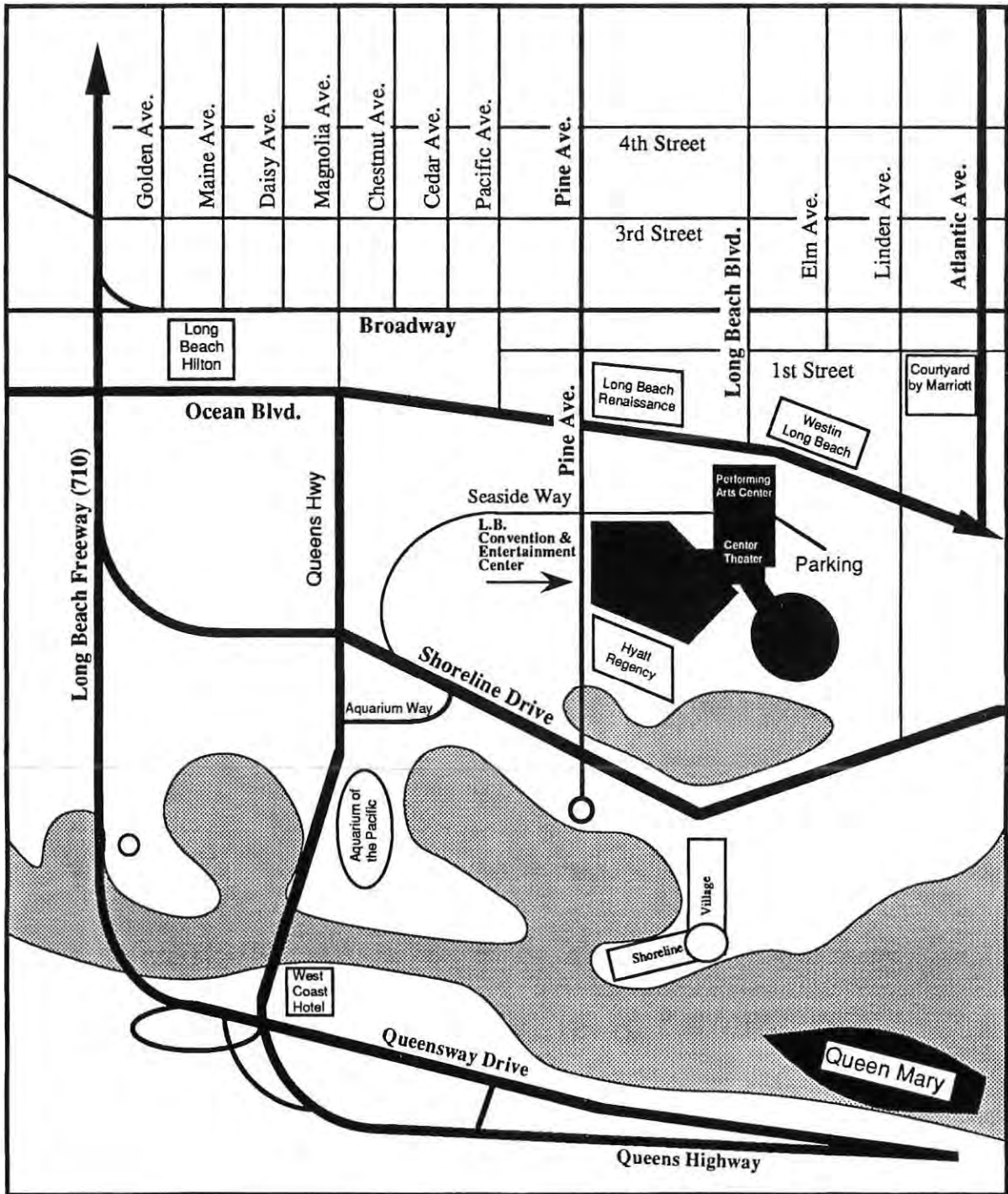

sustaining members

Acer Display Technology
 Ad-Vance Magnetics, Inc.
 Advance Reproduction Corp.
 American Panel Corp.
 Applied Concepts, Inc.
 Arconium
 Artesyn Solutions, Inc.
 ATI Technologies
 autronic - Melchers GmbH
 BPS
 Brewer Science, Inc.
 Brimar Ltd.
 Brown & Sharpe Surface Inspection Systems, Inc.
 Canon, Inc.
 CELCO
 Cherry Electrical Products
 Chunghwa Picture Tubes, Ltd.
 Clinton Electronics Corp.
 Colorado Microdisplay, Inc.
 Compaq Computer Corp.
 Corning Incorporated
 Corning Japan K.K.
 Crystaloid Technologies
 CTX Opto-Electronics Corp.
 DigiLens, Inc.
 Display Laboratories, Inc.
 DisplaySearch
 Displaytech, Inc.
 Dolch Computer Systems, Inc.
 Earth Computer Technologies
 ELDEC Corp.
 Electro-Plasma, Inc.
 Emco Electronics Ltd.
 Endicott Research Group, Inc.
 ERSO/ITRI
 FED Corp.
 F-P Electronics
 Futaba Corp. R&D Center
 General Vacuum, Inc.
 Gerome Manufacturing Co., Inc.
 Hamstar
 Hewlett-Packard Co.
 Hitachi, Ltd.
 Hoya Corporation USA
 IBM
 Imaging & Sensing Technology
 Imaging Systems Technology
 IMT Masken und Teilungen AG
 Incom, Inc.
 Industrial Electronic Engineers, Inc.
 Infinite Graphics, Inc.
 Infodex, Inc.
 Innova Electronics, Inc.
 Instrument Systems
 Interface Display & Controls, Inc.
 Interserv Corp.
 Interstate Electronics Corp.
 Ion Systems
 Ise Electronics Corp.
 Kent Displays
 LCD Lighting
 Lexel Imaging Systems, Inc.
 LinFinity Microelectronics, Inc.
 Lite Array, Inc.
 Lumin-Oz, LLC
 Micron Display Technology, Inc.
 Micronic Laser Systems AB
 Microvision Corp.
 Mitsubishi Electric Corp.
 Mitsubishi Electronics America
 Molex, Inc.
 Motorola FPD Division
 NEC Corp.
 Nippon Seiki Co., Ltd.
 OES/ITRI
 OKI Electric Industry Co., Ltd.
 Optical Coating Lab., Inc.
 Optrex America, Inc.
 Philips Flat Display Systems
 Phosphor Technology Ltd.
 Photon Dynamics
 Photo Research
 Pilkington Microcrystals Ltd.
 Pix Electronics, Inc.
 Planar Standish, Inc.
 Planar Systems
 Plasmaco, Inc.
 Polar Vision, Inc.
 Polytronix, Inc.
 Premium Allied Tool
 Progressive System Technologies
 Q.C. Optics, Inc.
 Quantum Data Inc.
 RF Power Products
 ROLIC Research Ltd.
 Sarnoff Corp.
 Schott Corp.
 Semiconductor Systems, Inc.
 Sharp Corp.
 SI Diamond Technology, Inc.
 Sony Corp. Research Center
 Stanford Resources, Inc.
 Superior MicroPowders
 Supertex, Inc.
 Symbol Technologies, Inc.
 Syntronic Instruments, Inc.
 Tamarack Scientific
 TDK Corp.
 TEAM Systems
 Techneglas, Inc.
 Teledyne Lighting & Display
 Therapixel, Inc.
 Thomas Electronics, Inc.
 Thomson Components & Tubes
 Three-Five Systems, Inc.
 Torrey Pines Research
 Toshiba America Electronic Components, Inc.
 Ultra Electronics Command & Control Systems
 ULVAC Technologies, Inc.
 UNIGRAF
 Unipac Optoelectronics Corp.
 Universal Display Corp.
 Ushio America, Inc.
 Video Electronics Standards Association
 Viratec Thin Films Inc.
 Vishay-Dale Electronics, Inc.
 Westaim Advanced Display Technologies
 Westar Corp.
 White Electronic Designs, Inc.
 WINTEK Corp.
 WinTron Technologies
 XCITEK, Inc.
 XMR, Inc.

index to advertisers

Ad-Vance Magnetics.....	51	Microvision	10,45
CELCO (Constantine Engineering Laboratory Company)	C4	Molex	7
Chroma ATE.....	47	Optrex America	C2
CyberTouch.....	16	Photo Research.....	43
Display Products Technology	49	Physical Optics Corp.....	51
EID	49	Pilkington Libbey-Owens-Ford	19
ELDIM.....	30	Polar Vision.....	29
Ergotron	8	Quantum Data	18
Goldentek Display America.....	42	Silver Cloud Manufacturing.....	53
H. L. Funk Consulting.....	16	Society for Information Display	44
Imaging and Sensing Technology Corp.....	6	Solomon Technology	45
IMT	53	Syntronic Instruments	23
Integral Vision.....	42	Team Systems	3
Ion Systems.....	9	Three Five Systems.....	C3
Kent Displays.....	11	3M Optical Systems.....	37
Klein Instruments.....	48,51	Toshiba.....	17
Kurt J. Lesker	8	Unigraf	46
LMDC.....	48	Vertex LCD.....	30
MicroJoin	31	Westar Corp	52
Micronic Laser Systems.....	36	XtroniX Corp	53
		ZC&R.....	5

Business and Editorial Offices

Palisades Institute for Research Services, Inc.
 411 Lafayette Street, 2nd Floor
 New York, NY 10003
 Jay Morreale, Managing Editor
 212/460-8090 x212 Fax: 212/460-5460

Sales Office

Palisades Institute for Research Services, Inc.
 411 Lafayette Street, 2nd Floor
 New York, NY 10003
 Tracy Leibowitz, Sales Manager
 212/460-8090 x211 Fax: 212/460-5460

SID '00

Long Beach, California

Long Beach

Convention Center

May 14-19, 2000

Mark Your Calendar Now!

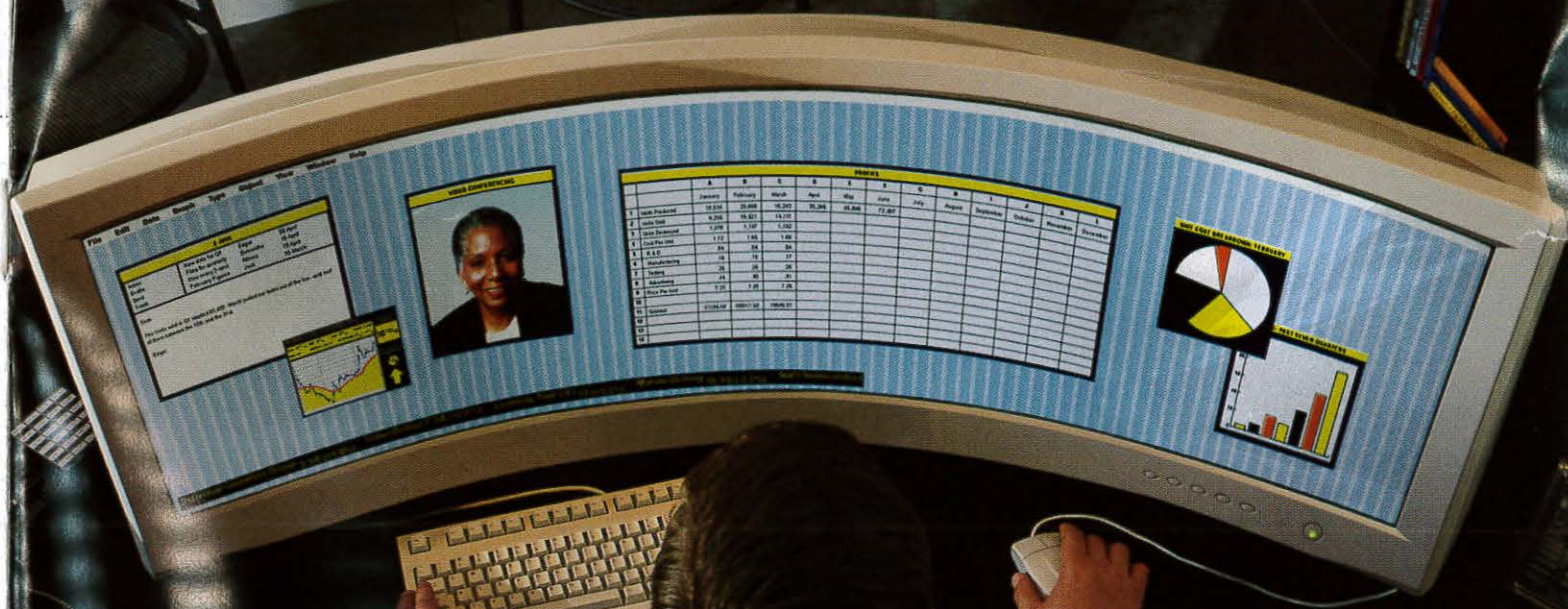

Wrap Your World Around You

Imagine a monitor where you can view your entire project at one time. A monitor with a viewing area so large, you can see multiple applications, a full detailed spreadsheet or an entire design without scrolling. Imagine a monitor that is thinner, lighter and has a large screen so you can see your world, your way. Three-Five Systems'

microdisplay products are ideal for applications that need to have superior image quality and high resolution for full visual impact.

Improving your life, your products, your image, your world - Three-Five Systems' extensive line of microdisplay products is taking display technology to a whole new level.



THREE-FIVE SYSTEMS, INC.®

We Display Excellence

Three-Five Systems, Inc.
U.S.A. • 602-389-8600
Fax: 602-389-8801

Three-Five Systems, Ltd.
Europe • 44-1793-549100
Fax: 44-1793-549135

For additional information:
email: micro@threefive.com
www.threefive.com

See Us at SID '00 Booth 901

Circle no. 43

1950 **CELCO** 2000

OUR VISION OF THE NEW MILLENNIUM

CELEBRATING OUR 50TH ANNIVERSARY



Mahwah, NJ
Yokes & Focus Coils

www.celco.com

Rancho Cucamonga, CA
Digital Motion Picture Recorders

See Us at SID '00 Booth 200

Circle no. 44