

FLAT-PANEL ISSUE

# Information

February 1999  
Vol. 15, No. 2

# DISPLAY

Official Monthly Publication of the Society for Information Display



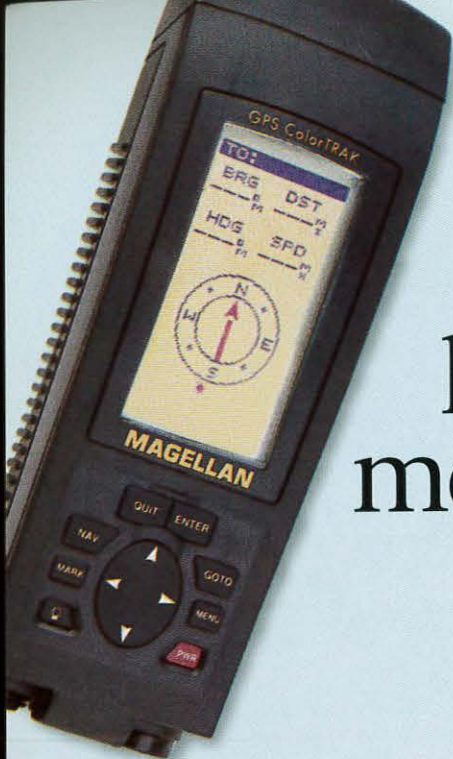

## ***Image Processors Offer Safe Passage Through the Interface Minefield***

- ***FPD Interfacing***
- ***Sharp's New-Generation AMLCDs***
- ***Inventing the PDP***
- ***Cutting PDP Costs***
- ***Madrid LCD Workshop Review***



The world  
plans, navigates,  
measures, monitors,  
plays, fishes,  
communicates,  
computes  
and  
displays with  
**Optrex** LCDs



And that's just the beginning.

The applications for LCDs keep growing and so does Optrex.

Why? Innovative engineering and design support, exceptional quality, and a nationwide distribution network. Our creative design approach allows you to develop new applications and enhance the performance of your existing products.

Most importantly, it allows **you** to create the custom or semi-custom LCDs that **turn your bright ideas into reality.**

Our customers like that. You will, too.

For more information, call (734) 416-8500, or fax (734) 416-8520 today.



**OPTREX**  
AMERICA, INC.

44160 PLYMOUTH OAKS BLVD. • PLYMOUTH, MI 48170  
(734) 416-8500 • FAX: (734) 416-8520  
lcdinfo@optrexusa.com

Circle no. 1

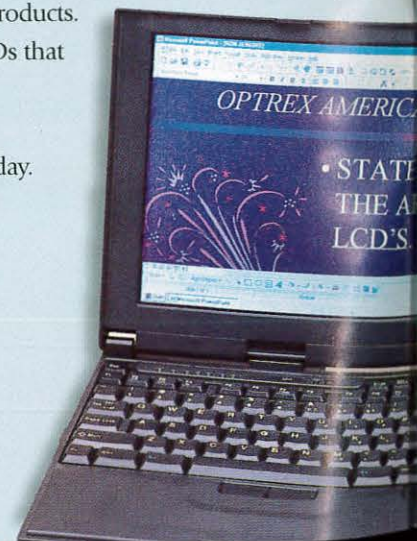



# Information FEBRUARY 1999 VOL. 15, NO. 2 DISPLAY

*COVER: The FPD-monitor market is growing, but interface standards are still in flux. One way to enjoy the action before margins are standardized out of the product, says Pixelworks, is to use an integrated image processor to make your monitor smart enough to handle any signal that's thrown at it.*



Credit: Pixelworks

For more on what's coming in *Information Display*, and for other news on information-display technology, check the SID Web site on the World Wide Web: <http://www.sid.org>.

## Next Month in *Information Display*

### SID '99 Preview Issue

- CRT Design and Marketing
- LCD-Monitor Market
- Self-Scanned a-Si AMLCDs
- SID '99 Preview
- SMAU Review

INFORMATION DISPLAY (ISSN 0362-0972) is published eleven times a year for the Society for Information Display by Palisades Institute for Research Services, Inc., 411 Lafayette Street, 2nd Floor, New York, NY 10003; Leonard H. Klein, President and CEO. EDITORIAL AND BUSINESS OFFICES: Jay Morreale, Managing Editor, Palisades Institute for Research Services, Inc., 411 Lafayette Street, 2nd Floor, New York, NY 10003; telephone 212/460-9700. Send manuscripts to the attention of the Editor, ID, Director of Sales: Michele Klein, Palisades Institute for Research Services, Inc., 411 Lafayette Street, 2nd Floor, New York, NY 10003; 212/460-9700. SID HEADQUARTERS, for correspondence on subscriptions and membership: Society for Information Display, 31 East Julian Street, San Jose, CA 95112; telephone 408/977-1013, fax -1531. SUBSCRIPTIONS: *Information Display* is distributed without charge to those qualified and to SID members as a benefit of membership (annual dues \$55.00). Subscriptions to others: U.S. & Canada: \$36.00 one year, \$7.50 single copy; elsewhere: \$72.00 one year, \$7.50 single copy. PRINTED by Sheridan Printing Company, Alpha, NJ 08865. Third-class postage paid at Easton, PA. PERMISSIONS: Abstracting is permitted with credit to the source. Libraries are permitted to photocopy beyond the limits of the U.S. copyright law for private use of patrons, providing a fee of \$2.00 per article is paid to the Copyright Clearance Center, 21 Congress Street, Salem, MA 01970 (reference serial code 0362-0972/99/\$1.00 + \$0.00). Instructors are permitted to photocopy isolated articles for noncommercial classroom use without fee. This permission does not apply to any special reports or lists published in this magazine. For other copying, reprint or republication permission, write to Society for Information Display, 31 East Julian Street, San Jose, CA 95112. Copyright © 1999 Society for Information Display. All rights reserved.

- 2 Editorial**  
*Sony's CRT Strategy: Flat But Not Thin*  
Ken Werner
- 4 The Display Continuum**  
*The Third Wave – Images and Wires ...*  
Aris Silzars
- 10 Navigating the Flat-Panel Interface Minefield**  
*Competing interface standards could stall the growth of digital imaging and display, but image processors offer a safe passage through the minefield.*  
Brad Zenger
- 14 Calendar of Display-Technology Events**
- 16 Sharp Microelectronics' Approach to New-Generation AMLCDs**  
*Sharp used computer modeling to carefully integrate a combination of optical compensating film, multi-domain cells, and lower-viscosity LC materials for its Super-V and Advanced Super-V (ASV) displays.*  
Joel Pollack
- 22 Inventing the ac Plasma Panel**  
*The ACPDP was invented for a specific application, but the early development uncovered many of the general issues that are still with us today.*  
Donald L. Bitzer
- 28 Advancements in Plasma Panels**  
*PDP sales are on the rise as manufacturers work to improve the picture quality while lowering prices.*  
Shigeo Mikoshiba
- 32 The View from Madrid**  
*The Third Ibero-American Workshop on LCD Technology combined some well-known faces with a distinctive point of view.*  
Ken Werner
- 42 SID '99 Hotel Information**
- 44 Sustaining Members**
- 44 Index to Advertisers**



### Sony's CRT Strategy: Flat But Not Thin

If you're in the CRT or CRT-based monitor business, you have two basic choices. You can slug it out with Chunghwa and Goldstar, producing high-volume units for razor-thin (or negative) margins, or you can add value for which users will, one hopes, pay more.

Sony is aggressively pursuing the value-added route with a line of high-end flat-screen CRT monitors. Sitting on my desk at the moment is an evaluation

unit of the Sony GDM-F500, a 21-in. (19.8-in. viewable) Trinitron™ monitor with a screen that is, for all practical purposes, perfectly flat horizontally and vertically. It has a 0.22-mm aperture-grille pitch that is constant across the entire screen - not variable as in earlier models - and a maximum horizontal scan frequency of 121 kHz that's good for a maximum screen resolution of 1800 × 1440 with a refresh rate of 80 Hz.

The faceplate, by design, deviates slightly from perfect flatness. The center was made 0.7 mm "higher" than the edges for a radius of curvature of 50 m in order to reduce or eliminate the illusion, common with flat monitors, that the flat screen is concave, said Treg Tyler, marketing manager for Sony Electronics' Information Technologies Marketing Division. In my experience with the evaluation unit, an initial impression of slight concavity quickly disappeared as the monitor was used. One problem with flat-screen CRT monitors is that the distance from the gun to the screen varies substantially with deflection angle, which seriously accentuates the problems of larger spot size, spot distortion, defocusing, and convergence in the corners with which all CRT monitors must contend to one degree or another.

Sony addresses these issues with a high-density electron gun, smaller spot, and reshaped beam. The cross section of the electron beam is "pre-shaped," depending on the intended beam-landing location to compensate for deflection-produced distortions. The result, said Tyler, is a net spot shape that is nearly the same everywhere on the screen.

How does this work in practice? In fact, very well. Subjectively, the image was stable and sharp everywhere. I ran the monitor through the advanced test suite generated by DisplayMate Professional (Multimedia Edition) from Sonera Technologies, Rumson, New Jersey, with my aging video card set to 1280 × 1024 × 256 colors. There was no visible geometric distortion, and the monitor delivered on its flat-screen promise: Straight lines were *really* straight.

Lines were so well focused in the corners that I could not detect fuzzing of white or black lines with the naked eye. (Only under ten-times magnification was it possible to see that both white and black lines lost some definition.) Moiré patterns were visible with DisplayMate's "full-resolution" and "two-thirds-resolution" patterns of vertical lines (which is not unusual with fine-pitch monitors), but the monitor's "Moiré Adjust" control allowed the moiré to be eliminated.

Colors were pure and convergence excellent. White-level regulation was faultless, and no ringing or overshoot was detected.

As befits a top-of-the-line monitor (the estimated selling price is about \$1900), Sony has included lots of bells and whistles. Input is switchable between an HD15 (standard computer video) input and five BNC connectors, and the monitor will hunt between the two to find a signal. A well-designed

*continued on page 40*

## Information DISPLAY

**Editor:** Kenneth I. Werner

**Managing Editor:** Jay Morreale

**Administrative Editor:** Ralph Nadell

**Assistant Editor:** Dian Mecca

**Contributing Editors:** Aris Silzars,

Bryan Norris, Chuck McLaughlin,

Joe Hallett, Alfred Poor

**Advertising Manager:** Jay Morreale

**Director of Sales:** Michele Klein

### Regional Associate Editors

Allan Kmetz (**Americas**)

*Lucent Technologies*

*Liberty Corner, New Jersey*

Shigeo Mikoshiba (**Asia**)

*University of Electro-Communications*

*Tokyo, Japan*

Alan Mosley (**Europe**)

*Central Research Laboratories*

*Hayes, Middlesex, U.K.*

### Advisory Editors

Ken Compton

*Clinton Electronics Corp.*

*Rockford, Illinois*

Carl Machover

*Machover Associates*

*White Plains, New York*

Peter Pleshko

*PEMM Services*

*Kingston, New York*

Alan Sobel

*Consultant*

*Evanston, Illinois*

Webster E. Howard

*FED Corp.*

*Hopewell Junction, New York*

The opinions expressed in editorials, columns, and feature articles do not necessarily reflect the opinions of the editor or publisher of *Information Display Magazine*, nor do they necessarily reflect the position of the Society for Information Display.

# Powerful New Video Generators. The Smart Choices.

## STANDALONE

### ASTRO VG-851/854

Dot Clock to 400 MHz  
Horizontal Scan to 300KHz

Extremely easy operation  
from front panel or PC

Highest Available  
Performance

256 Levels at all  
Frequencies

Fully compatible with  
all HDTV-formats-  
even 1080p

Accepts Bitmap-Files

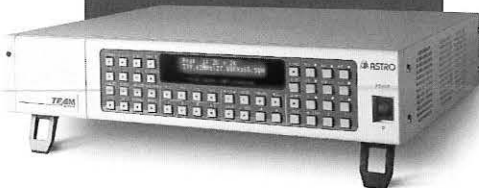

Standalone Units from **\$2950**

400 MHz for true 2K x 2K resolutions; Storage of more than 1000 Timing/Pattern Programs in Flash Memory and EEPROM; Fully PC-compatible with "Bitmap" capability; direct access to any parameter from front panel or through PC-programs. And any of the (E)EPROM you used in earlier units can still be used.

That's what we call High Performance, Flexibility and Ease of Operation!

## PC-BASED

### Team VG-530pc UNI VG-D300pc

PC-based Performance

Dot Clock to 300MHz

Horizontal Scan to 250KHz

Fully Programmable  
Patterns

Fully DDC Compatible

Accepts Bitmap-Files

UNI VG-D300pc Units  
with Win 95 &  
Win NT 4.0

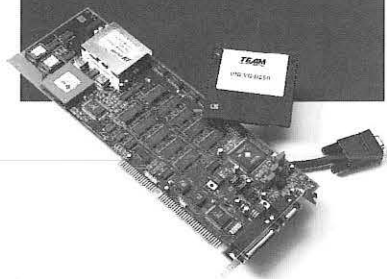

PC-Based Units from **\$2500**

300 MHz gives you ample margin if you work with Display Systems up to a 1600x1280 resolution. Its full "DDC" capability is an increasingly important asset in service and manufacturing applications.

Both PC-based units allow VESA-D.P.M.S. testing and the ability to import preset .pcx data files from other sources as "test patterns".

The user interface is DOS- and Win 95 & Win NT 4.0 respectively.

## DIGITAL

### ASTRO VG-826A

True "Digital" Video  
Generator

Dot Clock to 75MHz /  
150 MHz

Operated directly from  
a PC or with "Remote"  
Frontpanels

Very Compact &  
Lightweight

8 Bits resolution/  
pixel/ color

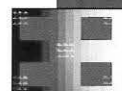

Digital Units from **\$5950**

Service, repair, evaluate or engineer FPDs? The Astro VG-826A is the Digital Generator for you.

It's small and light, yet has the performance to drive any single or multiplexed Flat Panel Device with a resolution of 24 bits per pixel up to a multiplexed frequency of 150MHz.

It can be programmed/operated from a PC, the RB-646A "Remote". Frontpanel or the RB-614C Controller.

Make the *Smart Choice*... Contact Team Systems

Call us: **1-800-338-1981** Visit us: [www.team-systems.com](http://www.team-systems.com)

**TEAM**  
systems

TEAM Systems, Inc. 2934 Corvin Drive, Santa Clara, California 95051  
Tel.: 408-720-8877 Fax: 408-720-9643

"Test And Measurement Technology"

## the display continuum



### The Third Wave – Images and Wires ...

by Aris Silzars

Paperless offices, computer-controlled houses, and video telephones – the dreams of futurists and entrepreneurs – all now relics in the virtual junkyard of technologies-that-never-were.

Have you stopped by a real (non-virtual) junkyard recently? Most likely not. But, if you were to visit one, you might be surprised to observe that they don't call themselves junkyards anymore. They now use higher-class terms such as "recycling center" or "center for rare replacement parts." Also, all of the larger ones have extensive communications networks to search multiple locations for whatever unusual object a customer might be trying to find. And since it's no longer "junk," but hard-to-find "quality replacement parts," the price is about the same as it would have been for a new one, if it were still available.

However, suppose you show up one day with your wonderful, but tired, antique vehicle that is held together by many of these same "rare replacement parts" that you had earlier been told are in such high demand. The response from the "recycling center" proprietor might go something like this. "You want me to give you how much for that piece of junk? Tell you what I'm gonna do. I'll do you a major favor and let you leave it here without charging you.... No, I'm completely serious.... Well, since you look like a nice college kid, I'll give you 50 bucks. Think of it as my donation to your education fund."

As we might expect, our virtual junkyard of technologies-that-never-were has many parallels to a real one. The technologies that wear out or have meager acceptance by the marketplace end up here with little or no value. But sometimes, with some modification – shall we say "recycling" – they can re-emerge looking "better than new."

As so many entrepreneurs have learned, having a seemingly great start-up business idea end up in the junkyard of technologies-that-never-were can be a costly proposition. Unfortunately, for reasons not yet fully understood, most futurists seem to be unaware of this repository of grand but impractical ideas – or maybe they just prefer not to acknowledge it. Thus, they keep on creating their enthusiastic and press-worthy, but unrealistic, visions of the future.

Let's try something just for fun. Let's take some of this technology junk and see if we can create something useful with it. However, we'll have to be somewhat selective since our junkyard of technologies-that-never-were has so much stuff in it from which we can choose. Each and every item stored here has something interesting about it that could turn out to be useful – even the paperless office.

Since we have to start somewhere, how about that big object over there? Yes, that geriatric junkyard resident known as the electronic home. You know, the one where the heating, lighting, dimmable windows, entertainment, and kitchen appliances were all going to be controlled from one central computer. Too bad the inventors didn't think about the "minor detail" that houses last over one hundred years and computers get obsolete about every 3-5 years. Even home appliances outlive computers by an order of magnitude. Is there anything at all that we could recycle from this electronic home that now sits in the corner of our technology junkyard, with its twenty-year-old computer with ferrite-core

*continued on page 38*

#### SID Executive Committee

President: A. C. Lowe  
President Elect: A. Silzars  
Regional VP, Americas: R. Donofrio  
Regional VP, Asia: C. Lee  
Regional VP, Europe: B. Needham  
Treasurer: A. R. Kmetz  
Secretary: R. L. Wisnieff  
Past President: W. E. Howard

#### Directors

Bay Area: H. Sherman  
Beijing: S. Ding  
Belarus: A. Smimov  
Canada: T. Schmidt  
Delaware Valley: J. W. Parker III  
France: F. Maurice  
Greater Dayton: R. Holmes  
Hong Kong: C. C. Chang  
Japan: A. Iwamoto  
Korea: M. Oh  
Los Angeles: P. Baron  
Metropolitan Detroit: V. Cannella  
Mid-Atlantic: D. Ketchum  
Mid-Europe: R. Mauch  
Minneapolis/St. Paul: V. Born  
New England: W. Hamilton  
Pacific Northwest: J. Rupp  
Russia: M. Tomilin  
San Diego: R. Ruff  
Southwest: R. Seery  
Taipei: F. C. Luo  
Texas: Z. Yaniv  
U.K. & Ireland: A. Mosley  
Ukraine: V. Nazarenko

#### Committee Chairs

Academic: C. J. Summers  
Archives/Historian: R. C. Knepper  
Bylaws: C. Infante  
Chapter Formation: H. Uchiike  
Communications: J. Rupp  
Convention: P. M. Heyman  
Definitions & Standards: R. Miller  
Honors & Awards: A. I. Lakatos  
Long-Range Planning: J.-N. Perbet  
Membership: J. W. Parker  
Nominations: W. E. Howard  
Publications: A. Silzars

#### Chapter Chairs

Bay Area: N. Balram  
Beijing: H. C. Hu  
Belarus: E. Kaloshkin  
Canada: A. Kitai  
Delaware Valley: L. Bryner  
France: H. Brettel  
Greater Dayton: J. Byrd  
Hong Kong: H. S. Kwok  
Japan: M. Maeda  
Korea: M. Han  
Los Angeles: M. Kesselman  
Metropolitan Detroit: S. Pala  
Mid-Atlantic: M. Anandan  
Mid-Europe: D. Theis  
Minneapolis/St. Paul: H. Holec  
New England: S. Atwood  
Pacific Northwest: T. Yuzuriha  
Russia: S. Darevsky  
San Diego: R. Ditzik  
Southwest: J. O'Donnell  
Taipei: H.-P. D. Shieh  
Texas: R. Fink  
U.K. & Ireland: C. Williams  
Ukraine: V. Sorokin

#### Office Administration

Executive Director: Dee Dumont  
Executive Assistant: Jenny Needham

#### Society for Information Display

31 East Julian Street  
San Jose, CA 95112  
408/977-1013, fax -1531  
e-mail: office@sid.org  
http://www.sid.org



## BM-SERIES ILLUMINANCE COLORIMETERS

# SEE COLOR AND LUMINANCE IN A WHOLE NEW LIGHT...

### *Work smarter, not harder.*

The Topcon BM-5A/BM-7 are fully integrated photometer/colorimeters that automatically read Luminance and Chromaticity coordinates, Color Temperature, or CIELAB and CIELUV values, in a single measurement. Manual operation of filter wheels, recording data and computing Chromaticity values are things of the past. The fully automatic BM-5A and BM-7 make laboratory work more accurate and efficient. All information is instantly available on a backlit rear panel LCD.

GP-IB or RS-232C interface options allow data to be easily exported to a personal computer. With easy selection of field aperture sizes, advanced design, and available accessory options, the BM-5A/BM-7 are ideal photometric tools capable of handling many diverse industry applications.

- Complete evaluation of color displays
- Reflected light measurements
- Automotive/ Avionics panels
- FPD and LCD testing
- SAE chromaticity measurements with optional software and hardware
- Production testing where high volume data recording is necessary
- Outdoor and remote operation with battery pack

Topcon has been a world-wide leader in electro-optical instrumentation standards for over 65 years. And we're committed to providing you with superior instruments, built to the highest standard of quality.

Call today at **1-800-223-1130**  
and make Topcon your partner in quality  
photometric instrument requirements.



Topcon America Corporation  
37 W. Century Rd., Paramus, NJ 07652  
Tel. 201-261-9450 • Fax 201-262-1504  
Visit us at: <http://www.topcon.com>



From the day we're born,  
we go into the world  
looking for what we  
want with our eyes.



**Almost nothing has a bigger impact** on product preference than the visual performance of a display. OCLI's image enhancement technology delivers **vivid colors, high contrast** and **crisp resolution** on direct view and projection displays. The difference is an immediately visible improvement that will win over even the most discriminating customers, the moment they see it.

Contact us for more information: [www.ocli.com](http://www.ocli.com)

USA (707) 545-6440 (888) 312-0848 EUROPE (49) 6162-93030 JAPAN (81) 3-3225-8974

Circle no. 4



# CM2250 & CM2250-PC

## Computer Monitor Analyzers

The Complete Solution For Troubleshooting, Testing, And Aligning High Resolution Displays.

- 250 MHz RGB Video Generator for complete testing of high bandwidth computer monitors
- Integrated Color Analyzer for critical white balance adjustments
- Service Process Generator simplifies and standardizes testing and alignment procedures
- DDC Capabilities give instant access to the monitor's formats

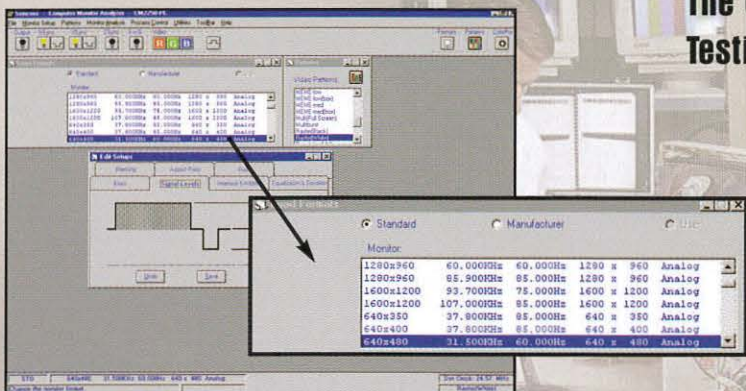

The CM2250 is fully programmable to match the requirements of the monitor under test. The CM2250 stores formats by manufacturer and model number for efficient testing of multi-format monitors.

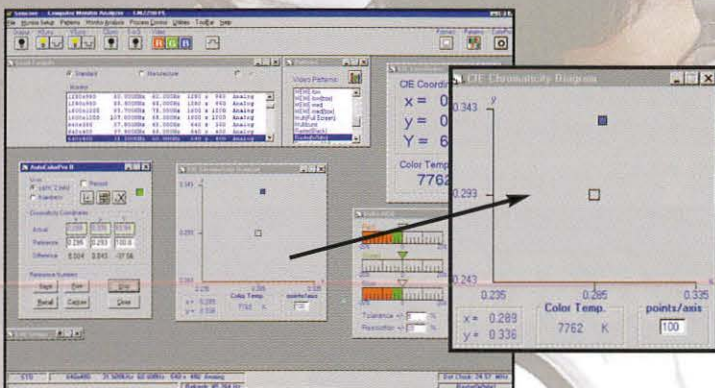

The CM2250's color analyzer delivers performance specifications required by the industry and is NIST traceable, giving you the confidence your monitors are aligned to laboratory precision.

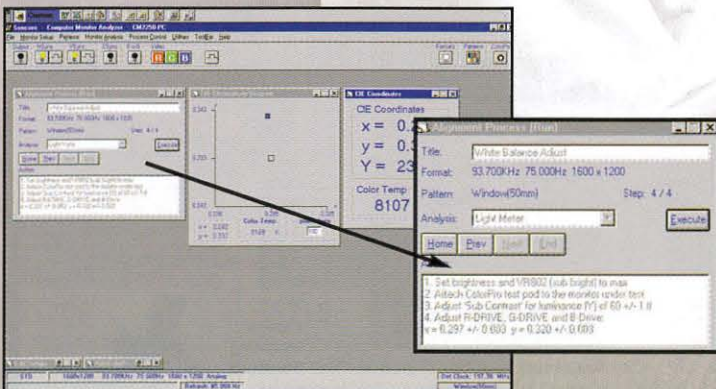

The CM2250's 'Service Process Generator' simplifies the creation of effective testing and alignment procedures and simplifies the use of these procedures.



**\$7995**

**CM2250 250 MHz  
Computer Monitor Analyzer**



**\$6495**

**CM2250-PC "Pro" 250 MHz  
Computer Monitor Analyzer**



Circle no. 5

## Westar's LCDcube™ Drive Electronics

solves the integration challenges in developing AMLCD-based displays

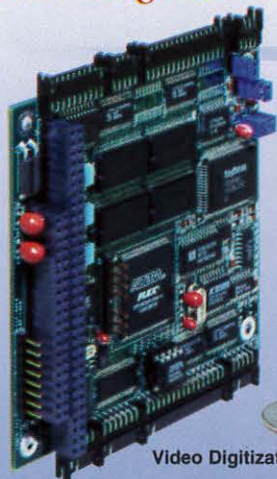

Video Digitization

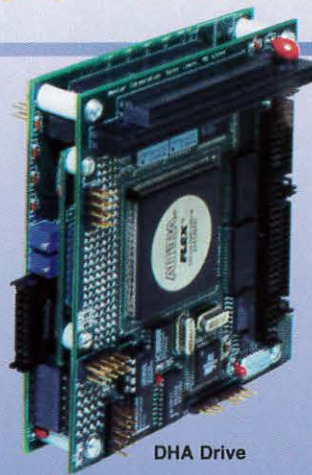

DHA Drive

- ✓ Accepts standard video inputs and drives avionics AMLCDs
- ✓ Reduce development time and cost with standard off-the-shelf solution
- ✓ Shrink overall display outline dimensions with the smallest possible form factor: PC/104
- ✓ Apply to any CRT retrofit application without redesign



Westar is a leading supplier of modular drive electronics and flat panel display test systems to the aerospace, computer, and FPD product industries. Contact us in the US at (314)298-8748, ext.286, or visit our website at [www.westar.com/id](http://www.westar.com/id).

Copyright ©1998, Westar Corporation. Trademarks are property of their respective owners.

Circle no. 6

## Flat Panel Monitor **ARMS™**

Call: 1.800.888.8458

Ergonomically position your flat panel monitors, laptops and keyboards wherever you need them—with Ergotron's **Adjustable Rotating Mounting Solutions**

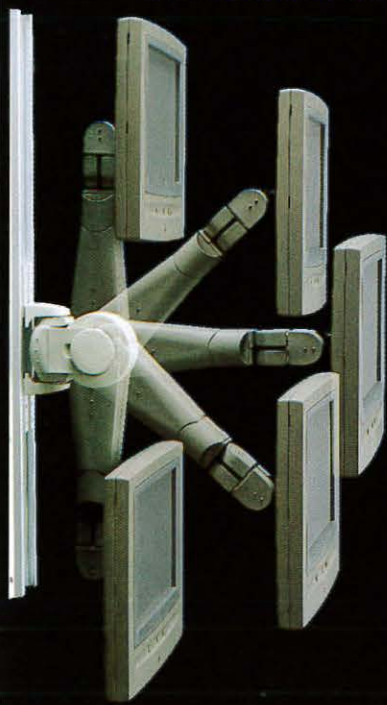

Mobile Solutions



Wall Mount Solutions



Custom Mount Solutions

Laptop Mounting Solutions



**ERGOTRON®**

1.800.888.8458 <http://www.ergotron.com>

Circle no. 7

## Check what you need in your display analysis system:

- ✓ flat panel tests
- ✓ CRT tests
- ✓ easy upgrades (hardware and software)
- ✓ standard for ISO, NIDL, and VESA testing
- ✓ optimized for fast, accurate, and automatic testing with many packaged test suites

## If you checked all of the above, you have chosen the Microvision SS200 Family of Display Analysis Systems

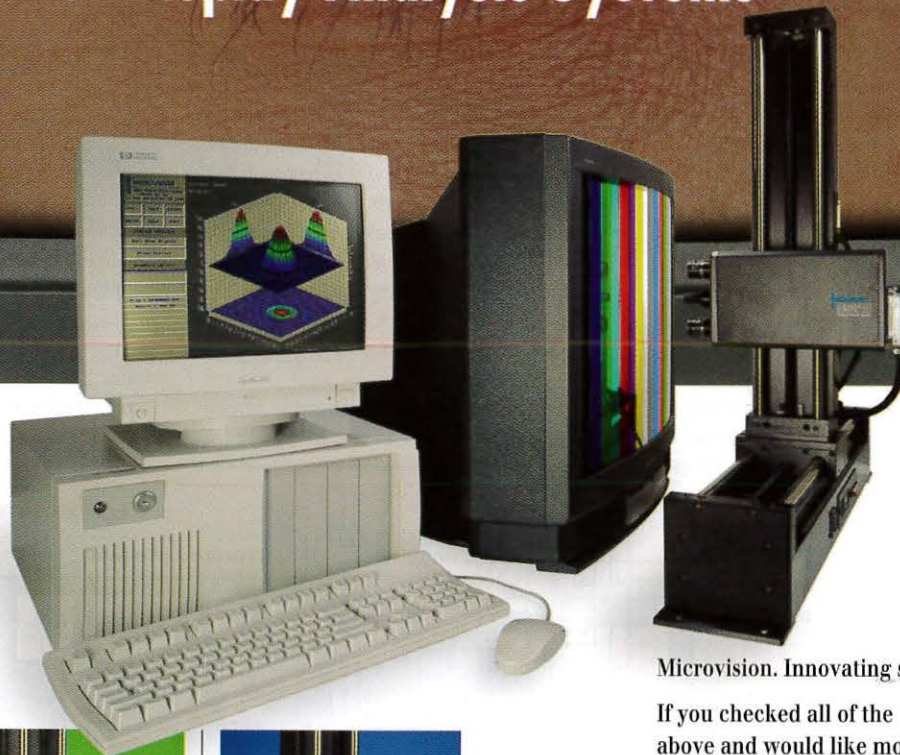

With the SS200 family, you can precisely, automatically, and completely measure display performance—and that includes flat panels.



### SS200

Complete turnkey system with computer, 6-axis positioner, monitor, software, and SS200 camera system. Automatically performs spatial and luminance measurements.



### SS210

You can easily field upgrade to the more powerful SS210 package, which provides all SS200 functions, plus an integrated spectrometer for spectral analysis and color measurements. Includes response time measurement capability.



### SS220

For flat panel testing, a field upgrade to the SS220 is easy. The SS220 provides spectrometer-based off-axis measurement, color analysis, color shift and luminance testing. Coupled with the SS210, this is the most comprehensive test system ever offered—at a fraction of the cost of individual test instruments. All tests are performed at NIST-traceable accuracy.

Microvision. Innovating since 1985.

If you checked all of the above and would like more information, call Microvision at (800) 951-5188.

## MICROVISION

*Dedicated to the Needs of the Display Industry*

550 High St., Suite 108 / Auburn, CA 95603  
Tel: (530) 888-8344 / Fax: (530) 888-8349  
Toll Free: 1 (800) 931-3188  
Email: [microvsn.com](mailto:microvsn.com)  
Web site: <http://www.microvsn.com>

International Reps:  
Japan - ARGO CORP., 06 559 5366  
Taiwan - SUPERLINK TECH., 02 705 7090  
Korea - B & P INT'L, 02 546 1457

## Navigating the Flat-Panel Interface Minefield

*Competing interface standards could stall the growth of digital imaging and display, but image processors offer a safe passage through the minefield.*

by Brad Zenger

**O**VER THE PAST YEAR, there has been a tremendous amount of exciting news that foreshadows a huge market for flat-panel displays (FPDs). Liquid-crystal-display (LCD) desktop monitors alone are forecasted to grow from less than 150,000 units in 1997 to nearly 10,000,000 units in 2002, according to Stanford Resources.

But this exciting market opportunity is at risk. Currently, there is a movement to change from the CRT-centric 15-pin VGA interface available on virtually every PC sold today to a new digital interface. The digital interface should provide the best image quality at the lowest cost for FPDs such as LCD monitors, but may put at risk the broad compatibility that the current standard provides. This standards transition is further complicated by the fact that the industry has not yet defined the digital-interface standard toward which we are moving.

This article will explore the competing interface standards by examining the key features of any potential FPD-interface sub-system that uses either the current or a future standard. Fortunately, a viable solution exists to help OEMs effectively manage their interface strategy in the face of this turmoil.

The basic points of this article are relevant for all FPD products, including LCD and digi-

tal-light-processing (DLP) projectors, plasma displays, and LCD monitors. The LCD monitor will serve as our example because this market is at a critical stage and must address the interface issues first if it is to reach its potential. Future markets include consumer products with a total market size of over 100 million displays, so the stakes are high.

The last year was a key period in the development of the market for desktop LCD monitors. Several significant market milestones were reached in 1998:

- LCD monitors with acceptable screen size emerged (14.1- and 15-in. models).

- The list prices of XGA LCD monitors dropped below \$1000 in the U.S.
- The overall market for LCD monitors approached 1,000,000 units.
- Image quality began to offer real competition for CRT monitors.

Poor image quality was a barrier to acceptance for early LCD monitors, but the display industry is improving performance while focusing on dramatic cost reductions to drive higher volume. To supplement cost reductions in the LCD panel itself, the industry is trying to replace the current 15-pin VGA analog interface with a new digital interface that

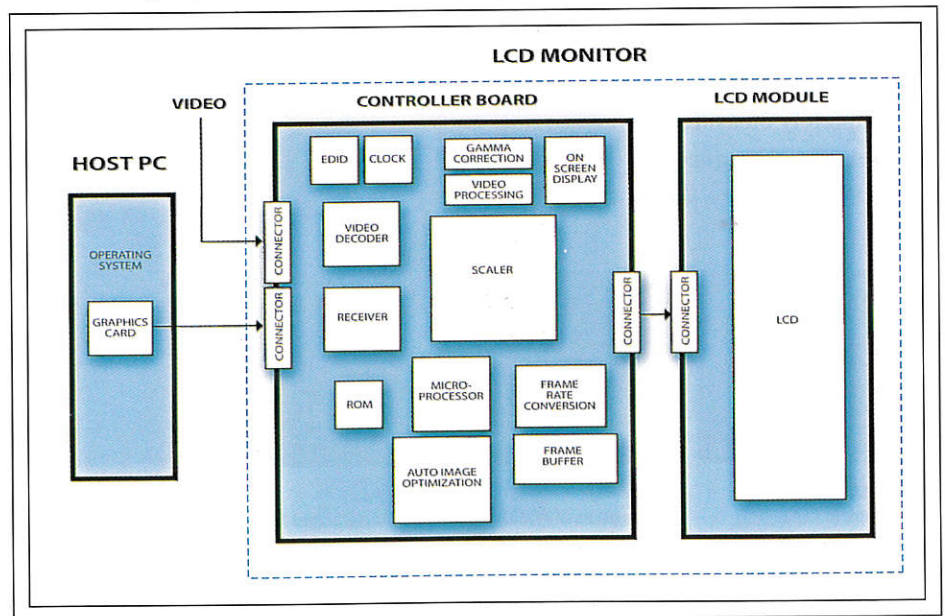

**Fig. 1:** A complete LCD-monitor interface or controller system contains several basic functional elements.

*Brad Zenger is Vice President, Marketing, at Pixelworks, Inc., 8100 S.W. Nyberg Road, Suite 100, Tualatin, OR 97062; telephone 503/612-6700 ext. 240, fax 503/612-6713, e-mail: bradz@pixelworksinc.com, Web site: www.pixelworksinc.com.*

should deliver better image quality and lower overall cost. These benefits are achieved largely by the elimination of the digital-to-analog signal conversion that is required today when using the VGA interface with flat-panel monitors.

The argument for this conversion would be simple if it were just digital vs. analog because that debate has been driven to a digital conclusion in many industries, including audio, HDTV, and cellular telephones. The issue for displays, however, is complicated by the fact that there are multiple digital standards being proposed, all of which are incom-

patible with the existing 15-pin VGA interface. In addition, the 15-pin VGA connector is showing signs of life. OEMs are pursuing high-quality low-cost analog-interface solutions which provide the additional benefit of legacy compatibility with over 300 million installed computers and are designed to help integrate desktop LCD monitors into the workplace.

**No "Standard" Digital Interface – Yet**  
A variety of proposed "standards" for digital-interface solutions for desktop LCD monitors are currently on the table (Table 1). Rather

than describe the technical merits of each of these standards, our purpose is to introduce the reader to key elements of each proposal.

Two elements are central to the debate to establish a digital-interface standard:

- 1) The electrical-interface methodology used to transmit the image data from the host computer to the monitor.
- 2) The connector that electrically connects the monitor to the host computer.

These elements have important compatibility ramifications for the end user.

As shown in Table 1, there are now four proposed digital electrical interfaces:

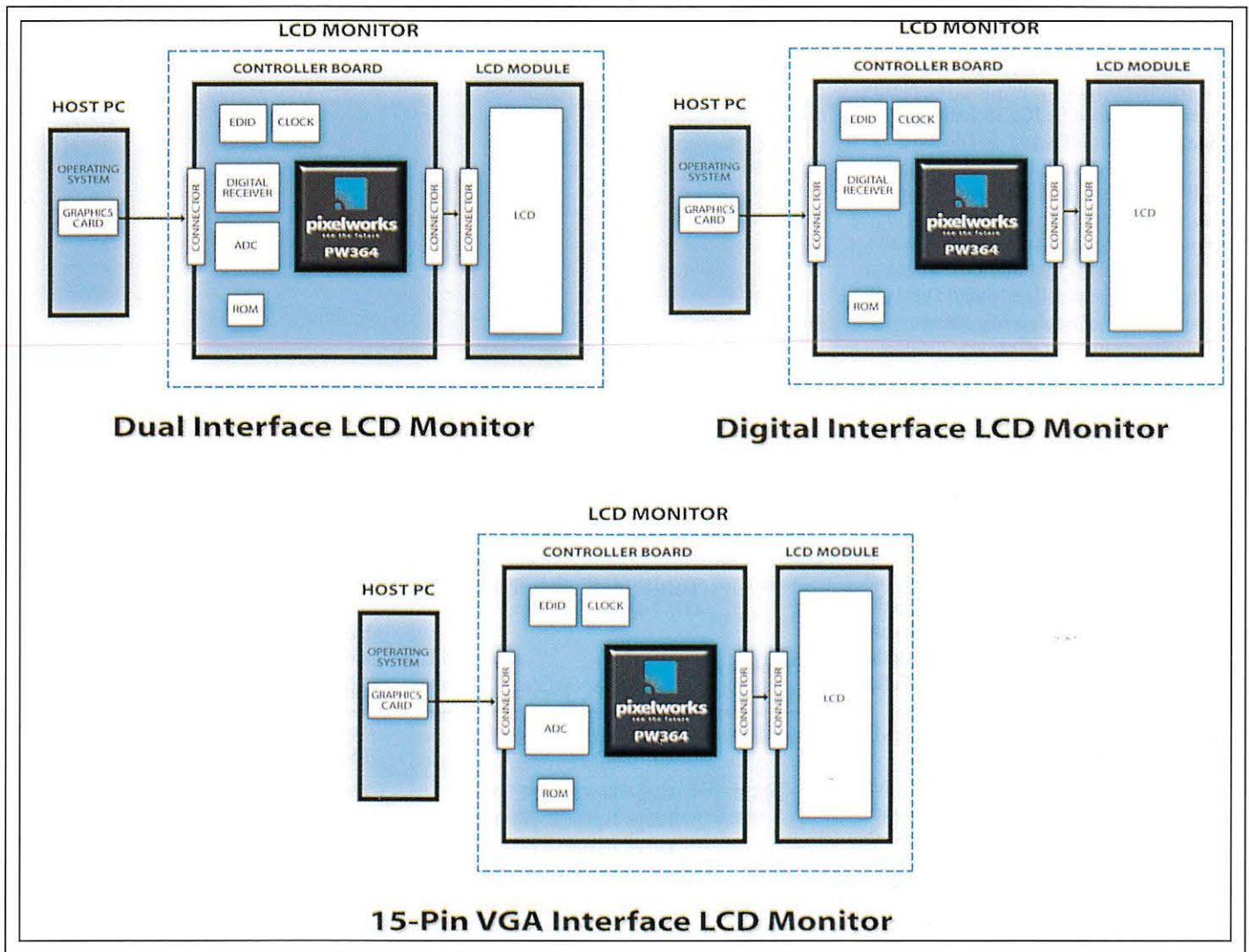

**Fig. 2:** The functional blocks represented in Fig. 1 have been integrated using an image processor in these LCD-monitor interfaces, which feature up-scaling, frame-rate conversion, video de-interlacing, gamma correction, and automatic image optimization. (Although image processors shown in the figure are Pixelworks ImageProcessors, other image-processing chips do exist.)

# FPD interfacing

- Transition-minimized differential signaling (TMDS),
- Low-voltage differential signaling (LVDS),
- Gigabit video interface (GVIF),
- LVDS display interface (LDI),

and no fewer than seven proposed connectors. Each proposed standard serves the same basic function: to transmit in digital format the graphics data from the host to the monitor. The proposing bodies can provide more technical details than we can cover here.

To put all of this in perspective, the digital transmission method is just one element of the desktop LCD-monitor interface subsystem. A complete LCD-monitor interface or controller system contains several basic functional elements (Fig. 1). Each of the blocks in the figure represents functionality that is typically implemented in specific ICs, including ASICs, FPGAs, or standard ICs such as DRAMs.

## Key Features of the FPD Interface

The functional blocks represented in Fig. 1 have been integrated to deliver specific end-user features, and they produce a new type of FPD that Pixelworks calls a "Smart Display" which is capable of intelligently interpreting any data source in order to provide the user with a high-quality image (Fig. 2). Key elements of the Smart Display include up-scaling, frame-rate conversion, video de-interlacing, gamma (color) correction, and automatic image optimization.

## Up-scaling

In up-scaling, a low-resolution image is intelligently processed to add information, so that when the new image is displayed at the native resolution of the display it looks smooth and does not exhibit blocky pixel artifacts. In the LCD-monitor application, this feature is often required to support low-resolution legacy applications such as terminal emulation and certain multimedia applications. Another application of this up-sizing capability is the ability to display normal, low-resolution video signals (NTSC, PAL, and SECAM) in a scalable window on a much-higher-resolution display. The monitor must provide this function because scaling support in graphics cards is inconsistent.

Speaking with OEMs confirms the importance of scaling for more than its critical impact on compatibility. The use of simple pixel-replication techniques for up-scaling

results in compromised image quality that is obvious to end users. Increasingly, OEMs are demanding the higher image quality provided by more advanced digital-signal-processing (DSP) scaling techniques. Editors reviewing these products are also highlighting the scaling quality in the monitors they review.

## Frame-Rate Conversion

Most FPD technologies - and particularly LCDs - have refresh-rate limitations, and material characteristics often dictate that the displays accept data at a certain rate. Most LCDs, for example, can only support a refresh rate of 60 Hz or less. But graphics controllers have video-output modes that are optimized for CRT displays, and provide refresh rates of 85 Hz and higher to minimize CRT flicker. (LCDs do not exhibit flicker, so higher refresh rates are not required.)

The Video Electronics Standards Association (VESA) has been working with operating-system and graphics-card suppliers, as well as PC and display OEMs, to establish a communications system called "Plug and Display" that allows the host's graphics subsystem to optimize its output - including refresh rate - for the target display. This system arranges for key timing information [extended display-identification data (EDID)] to be contained in the display device and transmitted to the graphics controller *via* a communications channel [the display data channel (DDC)]. While this system holds great promise, it has not been universally implemented and it is currently optimized for CRT displays. In

many cases, the operating system provides timing information to the graphics controller, but does not eliminate the need for FPD OEMs to provide frame-rate conversion to assure compatibility.

## Video De-interlacing

Increasingly, users are utilizing their computer monitors to display video data in addition to computer-graphics data. All current video standards are based on an interlaced format, which is incompatible with today's progressive-scan FPDs. Any FPD that is required to display NTSC, PAL, or SECAM video must have circuitry in the interface subsystem that converts the incoming signal from interlaced to progressive format.

## Gamma Correction

The color characteristics of an FPD often do not match those of a CRT. This means that an image displayed on an LCD monitor will not look the same as an image displayed on a CRT. As long as the CRT is the dominant display technology, the LCD must replicate the look of a CRT. This compensation is referred to as gamma correction. Typically, an LCD has an "S"-shaped gamma curve and a CRT has a smoother curve. The LCD must be compensated to look more like the CRT.

## Automatic Image Optimization

All of the proposed digital-interface standards include the direct transmission of the display clock from the host computer to the display. This eliminates the potential artifacts that can

**Table 1: Current and Proposed Interface Standards**

Proposing Organization	Major PC Participants	Electrical Interface	Connector	Monitor Marketshare (%)
VESA	All Major PC OEMs None Yet	Analog TMDS	VG 15-pin P&D	99.9 0
DISM	Large Japanese PC OEMs Large Japanese PC OEMs Large Japanese PC OEMs Large Japanese PC OEMs Large Japanese PC OEMs	TMDS TMDS LVDS LDI GVIF	MDR 26 MDR 20 MDR 26 MDR 40 MDR 14	0 0 0 0 0
DDWG	Intel, Compaq, Dell, Fujitsu, NEC, HP	TMDS	Not defined	0
DFP	Compaq, ATI, HP	TMDS	MDR 20	<0.1
VICI	Silicon Graphics	LVDS/LDI	MDR 36	<0.1

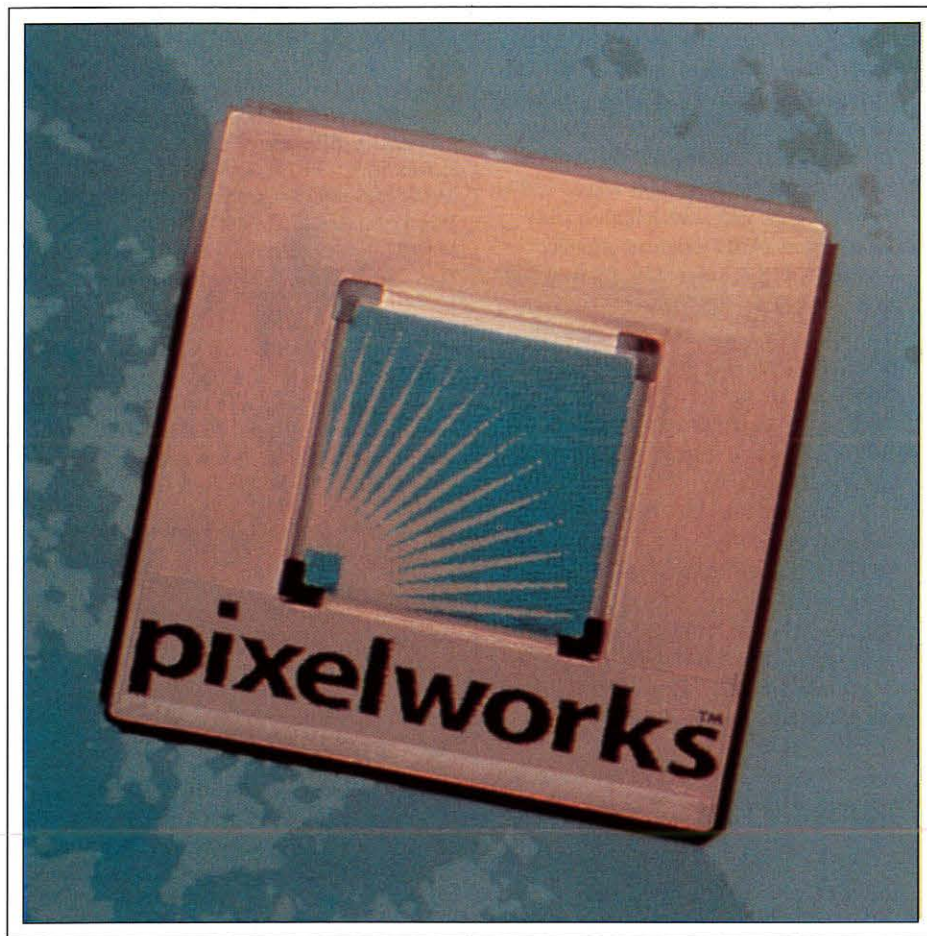

Pixelworks, Inc.

**Fig. 3:** Integrated image processors such as Pixelworks' PW364 combine all of the functions of a flat-panel interface system onto a single chip.

be seen in flat-panel monitors, and can result in a "crisper" image when compared to the current 15-pin VGA interface. The current 15-pin VGA monitor interface is optimized for CRT displays, and requires the FPD interface to determine the proper display-clock frequency and phase from the incoming sync signals. In addition, the image must be properly positioned on the display. In order to do this, the interface must intelligently determine key display parameters such as pixel-clock phase and frequency, as well as image size and position, from the incoming sync signals. Failure to do this correctly requires the user to adjust non-intuitive controls such as sync, phase, clock, and tracking to produce a high-quality image. The ideal solution to this problem would be a technology that allows the display to adapt automatically and continuously to achieve the optimal image quality. If done

properly, the user simply attaches an LCD monitor and it displays perfectly, paralleling the user's experience with CRTs.

#### Low Cost

An FPD's interface subsystem is second in cost only to the display module itself. As a result, the interface electronics are a primary target for cost reductions. There is a significant opportunity for cost reductions in FPD products through the elimination of non-essential functions and through higher levels of integration.

One of the key benefits common to all of the proposed digital-interface standards is the elimination of the conversion of the signal between analog and digital. Analog-to-digital conversion (ADC) is currently expensive, and typically results in loss of image quality. There is also a significant opportunity for cost reduction

through the integration of many of the capabilities shown in Fig. 1 onto a single chip.

#### The Solution

In the face of all the uncertainty in the interface arena, OEMs are looking for solutions that offer optimal image quality, ease of use, low cost, and, most importantly, flexibility. Over the next several years, the industry will certainly see a gradual transition from the CRT-centric 15-pin VGA interface to the flat-panel-optimized digital interface. OEMs should expect a consistent digital-interface standard to emerge. In the meantime, however, successful FPD-product OEMs will have to provide flat-panel monitors compatible with current and future interface standards while providing optimal image quality, ease of use, and the broadcast compatibility at the lowest cost.

New ImageProcessors offer FPD OEMs the features and flexibility they need. Pixelworks introduced the concept with its PW364 Image-Processor, which integrates all of the functions of a flat-panel interface system onto a single chip (Fig. 3). This single-chip display controller is compatible with all of the proposed digital-interface standards, yet provides excellent image quality when using the current analog-interface standard.

Such ImageProcessors provide the following features, assuring the user of excellent, automatically implemented image quality at low cost:

- **Image Resizing.** An effective image processor supports graphics resolutions from VGA to UXGA. Image-resizing technology expands or shrinks the input image to match the resolution of the display. Pixelworks' approach is to use DSP scalars that can implement finite-impulse-response (FIR) filters with programmable coefficients, so many types of filters can be designed. For example, a sharper or softer output image can be produced by changing the cut-off frequency of the filters, a technique that can be used to optimize image quality based on source material. Special effects such as non-linear scaling for aspect-ratio conversion are supported.
- **Video Processing.** An advanced image processor should support multi-standard video - including DTV, HDTV, NTSC, PAL, and SECAM - as well as computer inputs, and should perform all the pro-

# The Smart Choice in Digital Video Generators

## ASTRO VG-826



True "Digital" Video  
Generator



Dot Clock to 60MHz /  
120 MHz



Operated directly from a  
PC or with "Remote"  
Frontpanels

Very Compact &  
Lightweight

8 Bits resolution/  
pixel/ color



If you service, repair, evaluate or engineer modern Flat Panel Devices, the Astro VG-826 is the Digital Generator for you.

It's small and light enough to fit in your briefcase, yet has the performance to drive any single or multiplexed Flat Panel Device with a resolution of 24 bits per pixel up to a multiplexed frequency of 120MHz.

It can be programmed and operated from a PC or with the RB-646 "Remote" frontpanel or operated only with the RB-614C Controller.

Make the *Smart Choice*...

Contact TEAM.

Call 1-800-338-1981 or visit us at  
<http://www.team-systems.com>

**TEAM**  
systems

"Test And Measurement Technology"

Circle no. 9

## FPD interfacing

cessing needed to convert an interlaced digital video signal such as NTSC to a progressive-scan signal suitable for FPDs.

- **Frame-Rate Conversion.** The inclusion of semiconductor memory in an image processor permits compatibility with a range of refresh rates. This allows FPDs to provide the user with a high-quality image from a CRT-oriented graphics controller that is outputting, for instance, at a refresh rate of 85 Hz. The absence of frame-rate conversion in such a case leaves the user with a blank screen and significant frustration. The memory may be on board the integrated image processor, or a separate chip may be required.

At Pixelworks, we have integrated SDRA memory onto the PW364 for frame-rate conversion, and we have implemented programmable gamma correction and an integrated on-screen-display (OSD) controller. In addition, we have integrated a microprocessor, which means that Pixelworks ImageProcessors include complete software that implements full-featured FPD products with the fastest time to market.

ImageProcessors dramatically reduce component count, controller-board size, and cost while delivering improved performance. The higher levels of integration also reduce the amount of effort needed to develop the complete interface solution, dramatically reducing time to market. The flexibility of advanced image controllers allows OEMs to bring FPD monitors to market even in our current environment of fluid interface standards. ■

*Please send new product releases or news items to Information Display, c/o Palisades Institute for Research Services, Inc., 411 Lafayette Street, 2nd Floor, New York, NY 10003.*

# SID '99

Symposium, Seminar,  
and Exhibition

San Jose, California

San Jose Convention Center

May 16-21, 1999

## calendar

### Display Technology

**Asia Region Society for Information Display Symposium & Workshop.** Co-sponsored by SID Asia Region, SID Japan Chapter, IEICE, ITE, SID Korea Chapter, SID Hong Kong Chapter, SID Beijing Chapter, SID Taipei Chapter. Contact: SID Taipei Chapter Office; +886-3-5720409, fax -5737681, e-mail: [hpshieh@cc.nctu.edu.tw](mailto:hpshieh@cc.nctu.edu.tw).  
**Mar. 17-19, 1999 Hsinchu, Taiwan**

**The 1999 SID International Symposium, Seminar & Exhibition (SID '99).** Sponsored by SID. Contact: Mark Goldfarb, Palisades Institute for Research Services, Inc., 411 Lafayette St., New York, NY 10003; 212/460-8090 x202, fax -5460, e-mail: [mgoldfar@newyork.palisades.org](mailto:mgoldfar@newyork.palisades.org).  
**May 16-21, 1999 San Jose, CA**

**The 7th International Conference on Ferroelectric Liquid Crystals (FLC '99).** Contact: Prof. Wolfgang Haase, Condensed Matter Research Group, Institute of Physical Chemistry, Darmstadt University of Technology, Petersenstraße 20, D-64287 Darmstadt, Germany; +49-61-51-16-33-98, fax -49-24, e-mail: [flc99@tu-darmstadt.de](mailto:flc99@tu-darmstadt.de), <http://flc99.tu-darmstadt.de>.  
**Aug. 29-Sept. 3, 1999 Darmstadt, Germany**

**The 19th International Display Research Conference (EuroDisplay '99).** Sponsored by SID and in cooperation with ITG. Contact: Dipl.-Ing. Rupert Rempel, VDE Verband Deutscher Elektrotechniker e.V., Stresemannallee 15, D-60596 Frankfurt am Main; +49-69-6308-381, fax +49-69-9631-5213, e-mail: [100145-67@compuserve.com](mailto:100145-67@compuserve.com).  
**Sept. 6-9, 1999 Berlin, Germany**

**The 6th Annual Flat Panel Strategic and Technical Symposium, "Vehicular Applications of Displays and Microsensors."** Sponsored by The University of Michigan Center for Integrated Microsystems and the Metropolitan Detroit Chapter of SID. Contact: R. Donofrio, Display Device Consultants, 6170 Plymouth Rd., Ann Arbor, MI 48105; 734/665-4266, fax -4211, e-mail: [rldonofrio@aol.com](mailto:rldonofrio@aol.com).  
**Sept. 22-23, 1999 Ypsilanti, MI**

**The Fifth International Conference on the Science and Technology of Display Phosphors.** Sponsored by SID, PTCOE, and DARPA. Contact: Mark Goldfarb, Palisades Institute for Research Services, Inc., 411 Lafayette St., New York, NY 10003; 212/460-8090 x203, fax -5460, e-mail: [mgoldfar@newyork.palisades.org](mailto:mgoldfar@newyork.palisades.org).  
**Nov. 8-10, 1999 San Diego, CA**

**The Seventh International Color Imaging Conference.** Sponsored by IS&T and SID. Contact: IS&T, 7003 Kilworth Lane, Springfield, VA 22151; 703/642-9090, fax -9094, e-mail: [info@imaging.org](mailto:info@imaging.org).  
**Nov. 16-19, 1999 Scottsdale, AZ**



## Introducing the world's most advanced FED technology in a high-volume cluster tool.

The new Temescal® FCE-7000 from BOC Coating Technology is very big news: In fact, if you're looking for high-volume FED flat panel deposition with lowest cost of ownership and incredible flexibility, it just doesn't get much better than this...

To start with, there's BOC's world-class e-beam technology – which gives you the best uniformity, highest rates, longest life and largest source inventory, to cite just a few of its merits.

Then, this is a cluster tool. So you can deposit a single film or a

whole stack, in just about any way you'd like.

Plus, your panel size choices are virtually unlimited. The tool now handles up to 600mm x 720mm, which happens to be the largest in the world. But BOC can also configure it for even larger sizes upon request.

### Highest throughput. Lowest cost of ownership.

The FCE-7000 is a proven production tool that generates throughput speeds of from 10 to 60 panels per hour – and even up to 70 and 75 on certain processes. And when you combine that kind of throughput with high production quality levels, you get a very attractive return on your investment.

*Designed for production, BOC's flexible cluster configuration lets you deposit a single film or an entire stack.*

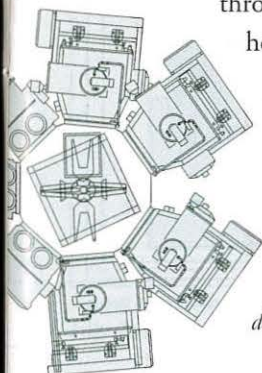

And this system also reduces downtime and requires less maintenance.

Plus, it provides more advanced automation and higher materials utilization. So you can see how it achieves the lowest cost of ownership of any flat panel deposition system in the industry.

*BOC's FCE-7000, the world's largest FED production tool, can process panels up to 600mm x 720mm.*

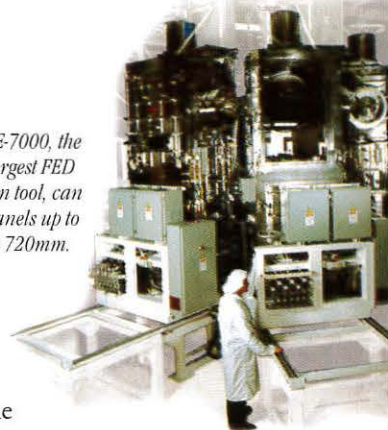

### A full spectrum of solutions.

BOC has been producing coating systems for more than 35 years now.

So they can provide not only high-throughput production systems, but also prototype R&D and intermediate systems, as well.

They can also provide you with an unmatched repertoire of process and system knowledge and managed engineering expertise.

So, even if your process is not yet fully developed, you can depend on BOC to help you answer the questions, negotiate the risks and get where you want to go.

Bottom line, it means smarter solutions – from the big performance guys, BOC. Call them and see for yourself...

Temescal, a part of BOC Coating Technology, 2700 Maxwell Way, Fairfield, CA 94585. (707) 423-2100. Fax: (707) 425-6071.

 **BOC**  
COATING  
TECHNOLOGY

# Sharp Microelectronics' Approach to New-Generation AMLCDs

*In the dizzying world of new LCD technologies and sharply improved LCD performance, Sharp used computer modeling to carefully integrate a combination of optical compensating film, multi-domain cells, and lower-viscosity LC materials for its Super-V and Advanced Super-V (ASV) displays.*

by Joel Pollack

**U**NLESS A DISPLAY APPLICATION calls for a single user sitting directly in front of the display, viewing angle is important. The first active-matrix liquid-crystal displays (AMLCDs) were an improvement over prior LCD technologies, but they still did not come close to the viewing angles offered by a typical cathode-ray-tube (CRT) display. Recent advances at Sharp have increased viewing angles to 160° in both the vertical and horizontal axes, while maintaining good contrast ratio, brightness, power requirements, and operating-temperature range, with response times suitable for the high-speed motion seen in sports and other multimedia applications. The result is a panel that can improve the performance of some prod-

ucts that already use LCD panels and make AMLCDs suitable for applications where CRTs were previously the only viable option (Fig. 1).

#### Viewing Angle Matters

There are many applications where more than one person must look at the same display. In financial arenas such as stock exchanges, sev-

*Joel Pollack is Vice President for Display Product Marketing in the Microelectronics Group of Sharp Electronics Corporation, 5700 N.W. Pacific Rim Blvd., Camas, WA 98607; telephone 360/834-8926, fax 360/834-8992. The author respectfully acknowledges the following sources: "Super-V TFT-LCD Technology" by Mitsuaki Hirata, Noriko Watanabe, Motohiro Yamahara, and Shigeaki Mizushima (Sharp Microelectronics Tenri LCD Development Center); and "Recent Trends of Display Devices" by Fumiaki Funada and Masaya Hijikigawa (Sharp Microelectronics LCD Laboratories and TFT-LCD Group).*



Fig. 1: Sharp's Advanced Super-V (ASV) panels have wide viewing angles in all directions.

Sharp Microelectronics Group

eral people look at changing data from different viewpoints on the floor. When an instructor presents information, students on both sides of the presenter read the display. In a kiosk, groups of short and tall users all scan the same point-of-information displays. Many test-and-measurement instruments are

viewed by engineers who are both sitting and standing, so viewing angle can be important in instrumentation. Sometimes a technician probing a circuit board may have to read an instrument from an awkward off-axis position. Workers moving about industrial process-control equipment must quickly check displays to

verify correct operation. Consequently, easy-to-read wide-angle displays can help spot process problems early.

Medical instruments monitor critical parameters that both a surgeon and an anesthesiologist verify by glancing sideways at a display. In the field, an emergency medical technician might quickly look at an instrument placed away from a motor-vehicle accident. Shifts in color or contrast at oblique viewing angles can make the difference between a correct medical assessment and a serious error.

Not all applications are as technical or sophisticated; people watching television at home also need to see clearly from different locations in a room. At the fall Japan Electronics Show, Sharp stated that "Sharp expects that all Sharp-brand TVs sold in Japan will have an LCD screen by the year 2005," and good viewing angles will be essential for these home-entertainment displays.

#### LCD Viewing Angles

Why do most LCDs have limited viewing angles? LCDs are built with linear polarizers in front of and behind the liquid-crystal (LC) cell. The two polarizers are orthogonally oriented; light would not pass through the display except for the actions of LCs. In the *undriven* state, LCs in normally-on twisted-nematic displays rotate the direction of polarized light by 90°, causing linearly polarized light from the input side to pass through the output polarizer. When pixels are driven, their LCs no longer rotate the polarized light, and light does not pass through the display. Liquid crystals are effectively light valves that operate on polarized light.

Twisted-nematic LC molecules have the property of dielectric anisotropy. In other words, each anisotropic LC molecule has a dielectric constant that is different for its x-axis than for its y-axis. Because of this dielectric anisotropy, an electric field will apply a torque to an LC to align it with the field. So, when a pixel is driven, the LC molecules (as a viscous fluid) will rotate in the applied electric field - much as a magnetically anisotropic compass needle will reorient in an applied magnetic field.

The relationships between molecular rotation, polarized-light rotation, and viewing angles are not simple, but the major factor in the viewing-angle problem involves off-axis light. Polarized light entering an LC from an angle - off-axis light - is treated differently

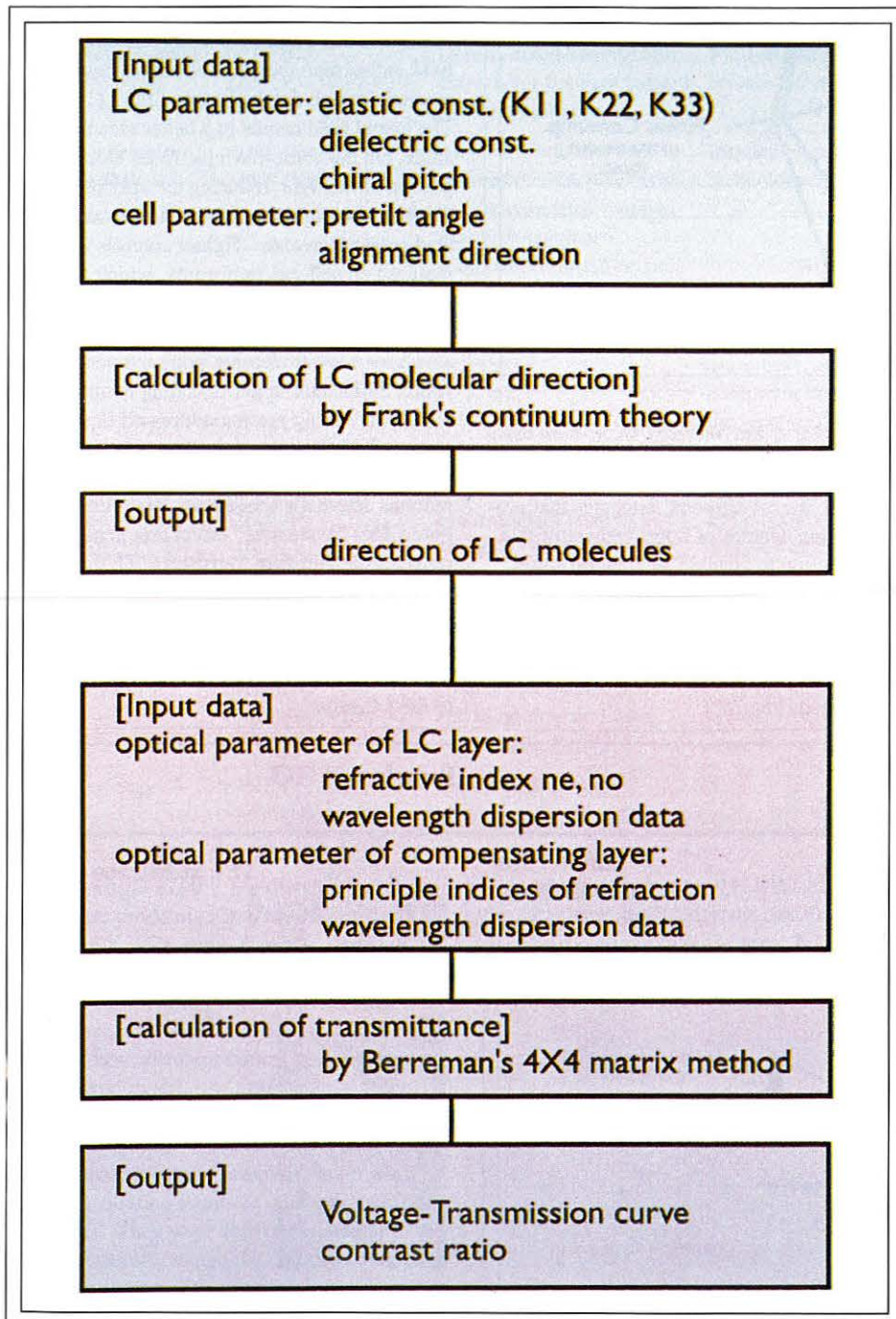

Fig. 2: A comparison of the improvements in wide viewing angles.

# LCD design

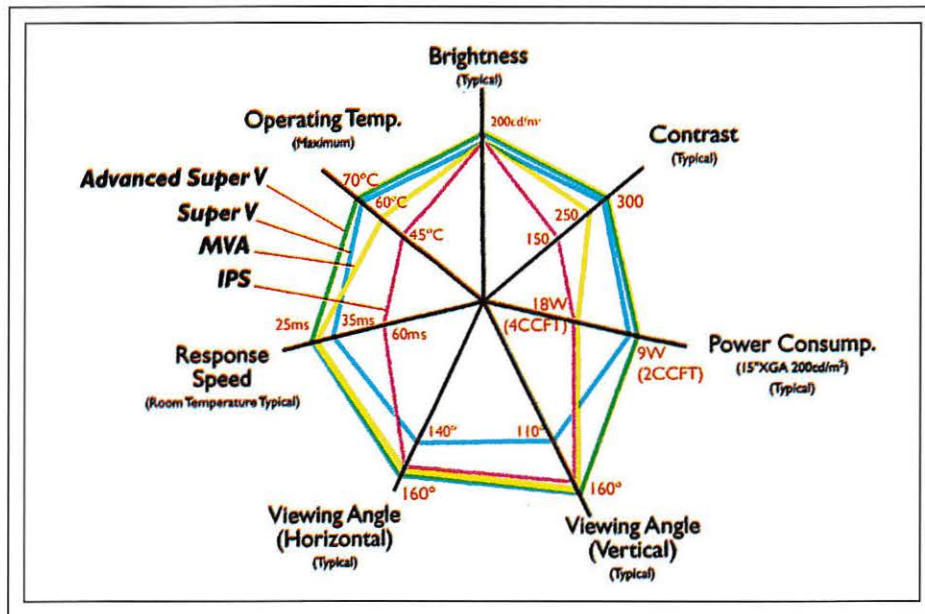

Fig. 3: Mitsuki Hirata, Noriko Watanabe, Motohiro Yamahara, and Shigeaki Mizushima used this process to model LCD and compensating-film performance.

than polarized light entering an LC from directly behind. The angle of incident light affects the contrast of the display. So, when viewers move away from a position directly in front of an LCD, they see more low-contrast off-axis light. When viewers move far enough off-axis, they see polarized light entering the LC at an angle so great that the LC can no longer perform the proper rotation on the polarized light. Contrast is diminished to the point that viewing angle is limited.

Viewing angle is also affected by wavelength dispersion. Liquid crystals operate differently on various wavelengths (colors) of light, especially when responding to off-axis incident light. So, viewers see color shifts as well as lower contrast as they move up and down and from side to side.

### AMLCD Viewing-Angle Improvements

Starting with the early days of LCD technology, researchers have sought ways to increase viewing angle with efforts focused on two major areas. One strategy has been to improve the LC and cell structure; the other has been to apply an optical compensating film to the LCD stack. A compensating film selectively retards the phase of the light wave and corrects viewing-angle limitations.

Many improvements have been made to date that extend the viewing angle of AMLCD

panels, relying on different strategies that produce varying degrees of improvement (Table 1). In addition to changes in viewing angle, these different improvements offer varying performance in other ways, including maximum operating temperature, typical brightness and contrast, response speed, and power consumption (Fig. 2).

In the axially symmetric mode (ASM), the LC cell is modified at each pixel so that it is more cylindrical in configuration. Normally, LC molecules all point in the same direction, but this cylindrical structure causes them to all orient about a center point in each pixel. This alignment results in improved viewing angle.

In-plane switching (IPS) relies on comb-like electrodes that generate a lateral electrical field, rather than the usual electrical field applied through the thickness of the LC cell. The lateral field results in a better viewing angle, but the comb-like electrodes block a portion of the light, reducing the aperture ratio. Brighter backlights are required, with associated power increases. Tighter controls are required on cell-gap uniformity, which decrease yield and increase manufacturing costs. LCDs with higher dielectric anisotropy also have a lower clearing-point temperature, which limits their upper operating temperature.

Displays using plasma-addressed liquid-crystal (PALC) technology rely on a special property of plasma: once a plasma is excited it remains active for a relatively long period of time. This "avalanche" effect functionally replaces the thin-film transistors (TFTs) used in AMLCDs. The fact that the display is plasma-addressed actually has little effect on viewing angle. Most viewing-angle improvements come from applying ASM technology to the LC cells.

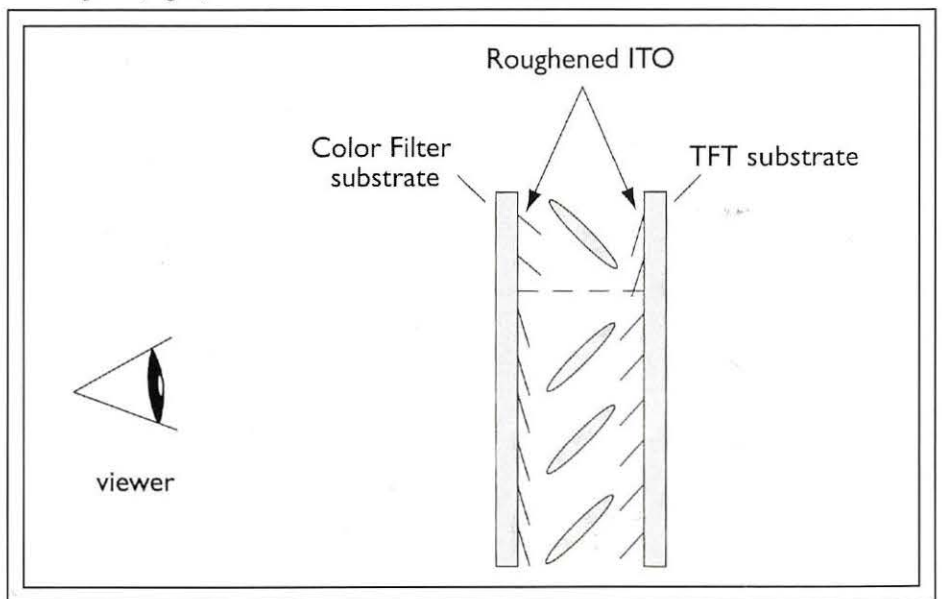

Fig. 4: This single multi-domain sub-pixel is combined with a compensating film (not shown) in Sharp's Advanced Super-V (ASV) technology.

**Table 1: Active-Matrix Viewing-Angle Improvements**

AMLCD Technology	Viewing Angle	Viewing-Angle Improvement Strategy	Remaining Problems
Active-matrix thin-film-transistor LCD (AMLCD)	80° (H) 45° (V) (+30°/-15°)	Original active-matrix design.	Contrast diminishes vertically, gray scale inverts horizontally.
Wide-viewing-angle film (WV Film)	140° (H) 110° (V) (+70°/-40°)	Optical-compensating film corrects for limits of twisted-nematic liquid crystal.	Vertical and horizontal off-axis color reversal.
Axially symmetric mode (ASM)	>160° (H) >160° (V)	Aligns the liquid-crystal material of each pixel in an axially symmetric manner, plus high-polymer compounded liquid crystal.	Limited by production technology.
In-plane switching (IPS)	>140° (H) >140° (V)	Inner (comb-like) electrode structure.	Transmissivity (low aperture ratio), uniformity, and contrast at high temperature, maximum operating temperature.
Multi-domain vertical alignment (MVA)	>160° (H) >160° (V)	Multi-domain vertical alignment of liquid-crystal cells.	Production availability, complex electrodes, sensitive to touch.
Plasma-addressed liquid crystal (PALC)	>140° (H) >160° (V)	Uses axially symmetric mode (ASM).	Low resolution, manufacturing issues.
Super-V (SV)	>140° (H) >110° (V) (+70°/-40°)	Optical compensating film and multi-domain liquid-crystal cells.	Viewing angle for the lower part of the screen.
Advanced Super-V (ASV)	>160° (V) >160° (H)	Improved Super-V.	

**Wide-Angle (160°) Displays**

Computer modeling has been designed to create 160° wide-angle displays. Super-V researchers started by building a computer model that not only predicted the optical performance of the liquid crystal, but also showed how different optical compensating films could modify the performance of the display. This tool allowed the engineers to design a compensating film to improve the off-axis light distribution (contrast) and color shift of the LCD. They were able to dynamically vary the LC optics to match the compensating film. This simulation of the interrelations of the LC design and the compensating-film design proved an important part of their breakthrough.

The block diagram for this simulation shows the parameters involved in the calculation (Fig. 3). The rotation of the LCs depends on the

material's elastic constants, dielectric constants, and the chiral pitch. The LC-cell parameters (pre-tilt angle and alignment direction) also affect the direction of the molecules. Next, the LC's optical parameters are combined with the compensating film's optical parameters, resulting in a voltage-transmission curve and contrast data for the modeled display.

Optical compensating films usually are composed of refractive-index ellipsoids that are parallel to the panel plane. Super-V researchers discovered a method of allowing a certain amount of z-axis bias between the panel and the ellipsoids. The new optical compensating film and LCD modifications corrected the usual horizontal gray-scale inversion, and contrast improved in the upper, left, and right quadrants. Gray-scale inversion also improved in the lower quadrant.

Matching the LCD and compensating film greatly improved the viewing angle from the top, left, and right of the display, but viewing the display from below still remained a problem. To improve viewing angle from below, Super-V researchers modified each sub-pixel so that a portion of the LCs were pre-tilted upwards and some were pre-tilted downwards (Fig. 4). As shown in the figure, one group of LC molecules (represented by a single ellipse) has an upward (12 o'clock) pre-tilt angle. Three ellipses represent groups of LCs with downward (6 o'clock) pre-tilt angles. This is called a "dual-domain alignment."

The team determined that the optimum ratio of the sub-pixel areas is 85% pre-tilted downwards, and 15% pre-tilted upwards. This is the ratio at which viewing angle is maximized, and is also uncompromised by gray-scale inversion. LCD sub-pixels can be fabricated with both 6 and 12 o'clock domains because the alignment direction of the LCs is

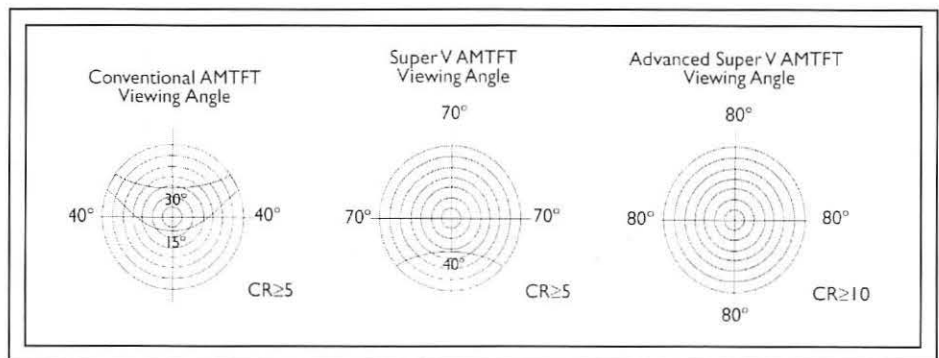

**Fig. 5:** These isocontrast plots show progressive improvements in AMLCD viewing angles.

Let us  
enhance  
**your**  
display!

# The Polar Vision Advantage

- Engineering Excellence
- Versatility
- Customization
- Convenience

Polar Vision is a leading manufacturer of optical filters for contrast enhancement, sunlight readability, viewing angle control, vandal resistance, anti-glare, EMI/RFI shielding, and anti-reflection — for CRT's, ATM's, touch screens, and flat panel displays. In addition we manufacture a full range of custom linear and circular polarized films and retardation films for use in information display products. Our facilities offer class 100 Clean Room optical lamination capabilities for rigid to rigid, flexible to rigid and flexible to flexible materials.

As a full-production facility with a uniquely qualified engineering staff, Polar Vision is your ideal outsource alternative.

**POLAR VISION INC.**

625 Alaska Ave. • Torrance CA 90503  
800.269.8801 • FAX 310.320.9357  
sales@polarvision-com  
www.polarvision.com

## LCD design

**Table 2: Wide-Viewing-Angle AMLCD Performance**

	Standard AMLCD	Super-V AMLCD	Advanced Super-V AMLCD
Viewing angle	80° H, 45° V (+30°/-15°) with contrast ratio > 5:1	140° H, 110° V (+70°/-40°) with contrast ratio > 5:1	160° H, 160° V with contrast ratio > 10:1
Contrast ratio (typical)	100:1 min.	300:1	300:1
Brightness (cd/m <sup>2</sup> )	180	200	200
Response time (ms)	60	45	25
Power (W) (15-in. 200-cd/m <sup>2</sup> XGA display)	10-15	9-12	9

set by the substrate surface with the highest molecular pre-tilt angle.

In order to fabricate such sub-pixels, the researchers needed a method of controlling pre-tilt angle. They focused on the relation between pre-tilt angle and the mean roughness of the alignment-layer surface. They discovered they could modify the roughness of the transparent indium tin oxide (ITO) material on the alignment-layer surface and control the pre-tilt angle of the LC. Finally, they aligned the boundary of the two domains with the TFT gate bus line to hide the disclination artifact, which would otherwise appear as a visible line.

Advanced Super-V (ASV) technology is the result of refinements to Super-V design, with further improvements in viewing angle compared with conventional AMLCD and Super-V displays (Fig. 5). These refinements also result in improvements in other performance characteristics (Table 2).

ASV displays are normally white rather than normally black (though users can select whichever background they wish with their software). Speed, brightness, power requirements, and operating temperature are all improved compared to earlier wide-angle displays. Most significantly, ASV displays have better viewing angles and higher contrast than previous displays.

An ASV AMLCD was shown for the first time ever at the Japan Electronics Show in October 1998. The first public exhibition was at the LCD International Show in Makuhari, Japan. Initially, Sharp will produce 18.1-in. SXGA (1280 × 1024) displays. Other sizes will follow in the future. ■

*Please send new product releases or news items to Information Display, c/o Palisades Institute for Research Services, Inc., 411 Lafayette Street, 2nd Floor, New York, NY 10003.*

## DISPLAYS CONSULTING GROUP

Design  
Development  
Production  
Components  
Measurements  
Applications

**Contact:**  
**H. W. Grossbohlin**

Phone 1-800-653-9857  
Fax: 805/526-1145

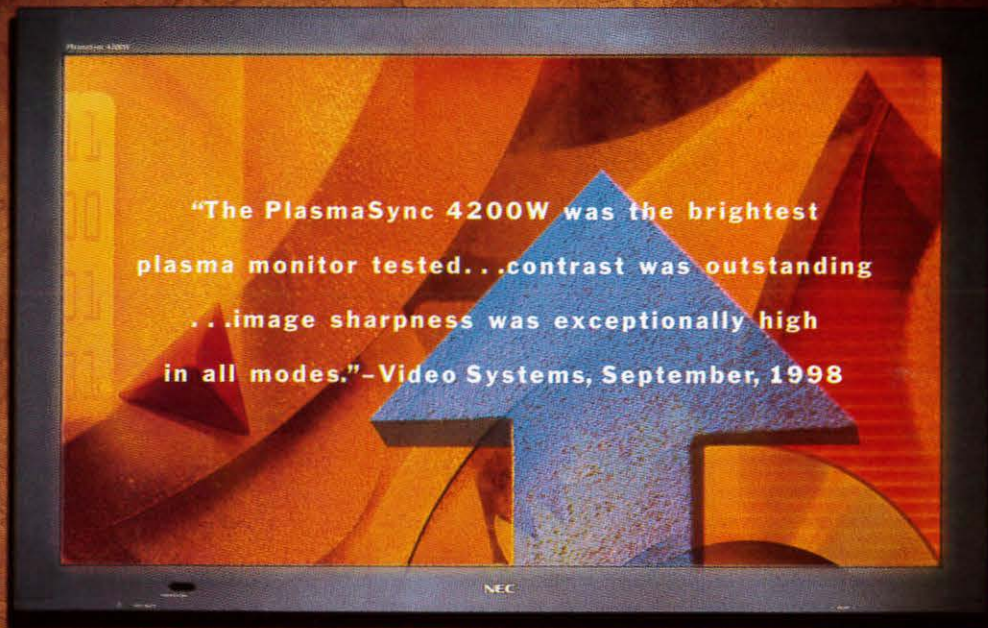

**With praise like this, you'd be glowing too.**  
**Introducing the PlasmaSync 4200W.**



Boardroom visitors, airport travelers, industry experts—there's no telling who the new PlasmaSync™ 4200W will impress next. Thanks to our unique Capsulated Color Filter™ technology, the 42-inch, 16:9 screen produces vibrant, realistic colors, fine detail and excellent contrast. The PlasmaSync 4200W gives you the flexibility you need, too—it's equally at home with computer, conventional video and HD video sources. Finally, we've fit all this performance in a cabinet that's just 3.5-inches deep—40% thinner than its main competitor. Call today to demo the PlasmaSync 4200W, or its equally impressive sibling, the 33-inch PlasmaSync 3300. Because while the PlasmaSync 4200W may look good in print, you haven't seen anything until you've experienced it in living color.

**NEC**

Take the Demo Showdown. For a free product demonstration, call (800) 449-0967.



To learn more, visit [www.nectech.com](http://www.nectech.com). Or call (800) NEC-INFO. Expect more. Experience more.

# Inventing the ac Plasma Panel

*The ACPDP was invented for a specific application, but the early development uncovered many of the general issues that are still with us today.*

by Donald L. Bitzer

**T**HE INVENTION of the plasma-display panel (PDP) was driven by a specific need: to provide a multimedia display for a computer-based education project called PLATO (Programmed Logic for Automatic Teaching Operations). PLATO was invented in 1960 at the Coordinated Science Laboratory (CSL), an interdisciplinary laboratory located at the University of Illinois. CSL's research projects ranged from advanced radar systems to electric vacuum gyroscopes for accurate long-term navigation, and were supported primarily by the Joint Services Electronics Program of the Department of Defense. Because education and training was important to the military, computer-based education was an area of research.

One of the important requirements of the PLATO system was a display that would support graphics with superimposed picture images. Up to that time - the early 1960s - almost all computer displays were alphanumeric (usually teletype machines). The high cost of memory prevented the construction of economical graphics terminals, and storage tubes were developed to meet this need. A storage tube of the scan-converter type was used for the PLATO system. This allowed the computer to digitally write alphanumeric

---

*Donald L. Bitzer is Distinguished University Research Professor, Department of Computer Science, College of Engineering, North Carolina State University, Campus Box 8206, Raleigh, NC 27695-8206; 919/515-3998, fax -6497. Dr. Bitzer is one of the inventors of the ACPDP.*

characters and draw graphics on the storage tube. The tube was then re-scanned in a television format for presentation on a television screen. Slide images were also scanned and the resulting video output added to graphics output, thus presenting the superimposed image on the television screen.

This approach met our research needs in the laboratory, but it was expensive, used wide bandwidth, and required constant maintenance. By 1963 it was clear that we needed a drastically different type of display to expand the PLATO project outside the laboratory environment. This display had to have graph-

ics capability, be low in cost, have inherent memory (but of a sort that did not keep any pixel from being written or erased), and had to be flat and transparent so that selected slide images could be superimposed by rear projection. Such a display did not exist, but the requirements suggested that it be made of gas (for light-generation and memory) and glass (for rear-projection transparency) (Fig. 1).

### Previous Gas Displays

In the early 1950s, researchers at the Burroughs Corporation developed a numeric indicator tube that could be used as a counter. Differ-



*Plasma display co-inventors Donald Bitzer, left, and Gene Slottow, right, circa 1967.*



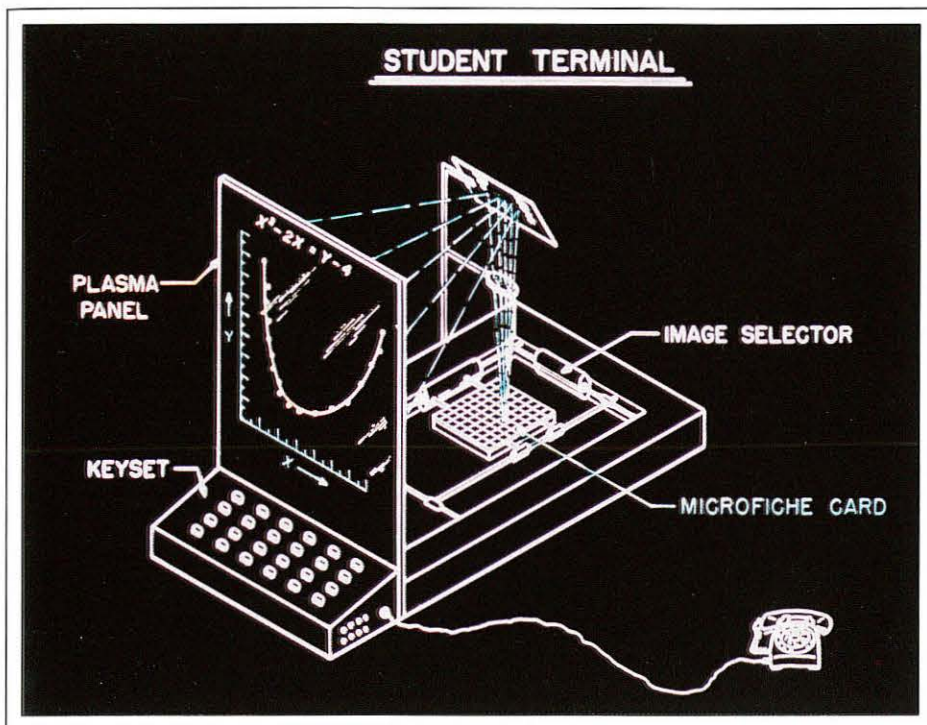

D. L. Bitzer

**Fig. 1:** The invention of the PDP was driven by the need for a multimedia display for a computer-based education project called PLATO.

ently shaped elements in the tube could be selected to glow in a gaseous environment. After several materials problems were solved, this numeric indicator tube – known as the Nixie tube – was mass-produced by Burroughs. As early as 1954 there were attempts to make a dc matrix display, in which a series resistance was required for each cell in order to prevent cross-addressing problems from previously lit cells. In the early '60s, Lear Siegler fabricated a  $10 \times 10$  matrix display with a resistance embedded at each cell. Fabrication of such dc discharge displays was very difficult and larger displays did not seem feasible.

It was in this environment, in 1963, that I began to investigate other methods of driving a gas-discharge matrix display. In particular, I wanted to explore methods that would avoid the need for resistors at each cell. In mid-1963, I assigned one of my graduate students, Robert Willson, the project of using capacitors with high-frequency driving signals and gas discharges as addressing elements – as well as display elements – in the matrix.

Bob used discrete elements of neon tubes for the panel matrix cells and addressing cells, and implemented the rf coupling to the

addressing cells with metal foil on the outside of the neon tubes. Although the memory margin – the difference between the initial firing voltage of the gas in each cell and the voltage needed to sustain the discharge – was small, the method worked and we were able to address a small array of neon bulbs. I left for India in January 1964 for 6 months, keeping in touch with Willson as he continued to improve the margins for this technique.

### Putting the Idea Together

Upon my return in July 1964, I was in my office looking over the results of Bob's work. Later that afternoon Gene Slottow, a colleague, joined me to wait for our wives to drive us home. Both wives were late in arriving, so we began a discussion focused on reducing the early work to as simple a configuration as possible, utilizing the natural capacitance characteristics of a glass panel. We thought that by placing the electrodes on the outside of the panel the gas discharge would be isolated from the electrodes by the capacitance of the gas-glass structure. We theorized that this non-resistive impedance should work if we used an alternating voltage. In the next

15 minutes our discussion led to the basic configuration of today's PDPs. Our wives still think that they and their tardy arrival deserve part of the credit for the invention.

However, memory margin was still in question for this configuration since the memory in a dc discharge in contact with electrodes is caused by the space charge changing the virtual distance between the electrodes. Our design had an ac discharge with no electrodes in contact with the gas discharge.

The next day we asked Willson to construct a one-cell matrix so that we could explore memory-margin mechanisms. Operating with limited resources, we salvaged a used vacuum system and constructed the first one-cell panel from microscope cover slides 1 in. square and 0.006 in. thick (Fig. 2). The panel was a sandwich made of three cover slides. The center glass was used to support the two outer layers and had a 0.015-in.-diameter hole ultrasonically drilled in the center to form the cell.

The outside glass slides had a thin gold electrode 0.01-in. wide deposited on one surface. These glass slides were placed above and below the center glass so that the electrodes were on the outside, orthogonal to each other, and centered over the hole in the center glass. This sandwich was inserted into a slot at the end of a glass tube and all edges sealed with a special epoxy. The glass tube was then connected to our rebuilt vacuum system, pumped down, and backfilled with neon gas.

A high-voltage sinusoidal driving source, constructed with vacuum tubes, had a frequency that could be varied from 200 to 500 kHz. This driving source would be used for over a year to carry out the early experiments. An accidental touching of this high-voltage high-frequency source did not produce an electrical shock, but rather burned a small neat hole in one's skin. (As a result, around the laboratory the source was referred to as the "mole-removing machine.")

Much to our delight, when we applied this driving source to the electrodes on the outer glass plates, the cell lit and exhibited several volts of memory margin. This demonstrated to us that a matrix-array panel of this construction could be made to work. Our expectations were bolstered even more when we discovered that we had a serious leak in the vacuum system. We fixed the leak and repeated the experiment, expecting the memory margin to be improved. Much to our surprise, the margin nearly disappeared. We were

## PDP history

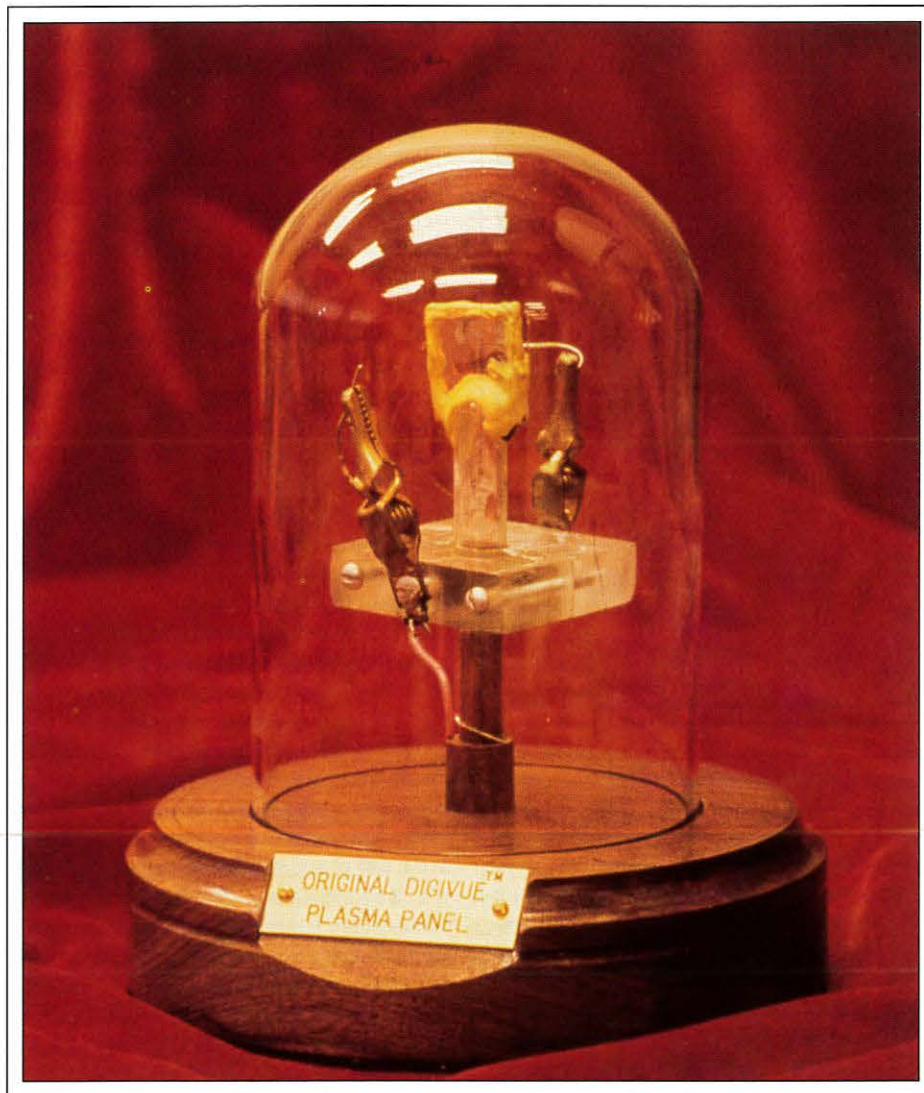

**Fig. 2:** The first 1 × 1 plasma-display panel.

very fortunate to have had the original leak in the vacuum system.

Later we realized that a memory margin could have been obtained in the pure neon if we had had a pulse-driving source available. Speculating that nitrogen was the main component in the leak, we began experimenting with nitrogen and various other gas mixtures. Using the sinusoidal driver, we determined that a gas mixture of 144 mm Hg of neon and 6 mm Hg of nitrogen gave the best percentage of memory margin. The firing voltage for this mixture was 500 V with a memory margin of 125 V - the sustain voltage was 325 V. The nitrogen produced a blue discharge in the cell, so our earliest panels had a distinct blue hue.

sition to the field produced by the external-driver voltage. The discharge stopped when the total field was sufficiently reduced. The short - 0.1  $\mu$ sec - light and current pulses supported this theory.

A second experiment was designed to check this concept. A high-voltage ramp driver was applied to the cell. The cell first fired when the firing voltage was exceeded, but the cell fired again when the external voltage became the sum of the firing voltage and the internal voltage created by charge transfer to the walls during the preceding discharge. This effect - which we dubbed "wall charge" - strengthened our confidence in the memory model.

We were now able to model the stability and memory margin based upon the various parameters affecting the shape and intensity of the gas discharge. Each gas discharge produced a wall voltage that extinguished the discharge, but this same wall voltage increased the voltage across the cell when the external voltage was reversed, which then created the next discharge. Gene Slottow built a mathematical model that allowed us to compute the dynamic changes in the wall voltage as the external voltage changed. In order to demonstrate these basic principles in slow motion, a physical model of a single cell was built using a neon bulb and a capacitor. These one-cell results were first published in the proceedings of the Fall Joint Computer Conference in 1966.

Still to be checked was the elimination of the effects of lit cells on causing address ambiguities. The addressing-ambiguity problem was one of the reasons that resistors were needed at each cell in the panels that had internal electrodes. However, in our design the discharge occurred only for a small fraction of the time in a lit cell, and there existed a natural capacitive impedance at each cell.

We were confident that the matrix cell addressing would work properly. However, our 1 × 1 matrix experiment did not convince many others that the process would work on large matrices. The most common comment was "a lot of things have worked on a 1 × 1 matrix." Thus, our next task was to build a 4 × 4 matrix display to satisfy the skeptics.

We now had many new ideas to investigate, ranging from the design of electronic drivers to panel construction and gas mixtures. The Behavioral Science Branch of ARPA had provided me with a small grant to investigate the principles of computer-based education. I could not think of more important principles

Our next step was to understand the cell factors related to the memory margin. We suspected that the primary cause was a surface effect since the surface-to-volume ratio was comparatively large. The memory appeared to be related to the electrons and ions created in the discharge because measurement of the light output from the cell and current from the resulting discharge appeared as short pulses. In addition, larger current pulses produced more memory.

We speculated that the ions and electrons produced in the discharge moved in the electric field produced by the external driver and collected on the inner glass surfaces. This produced an additional electric field in oppo-

D. L. Bitzer

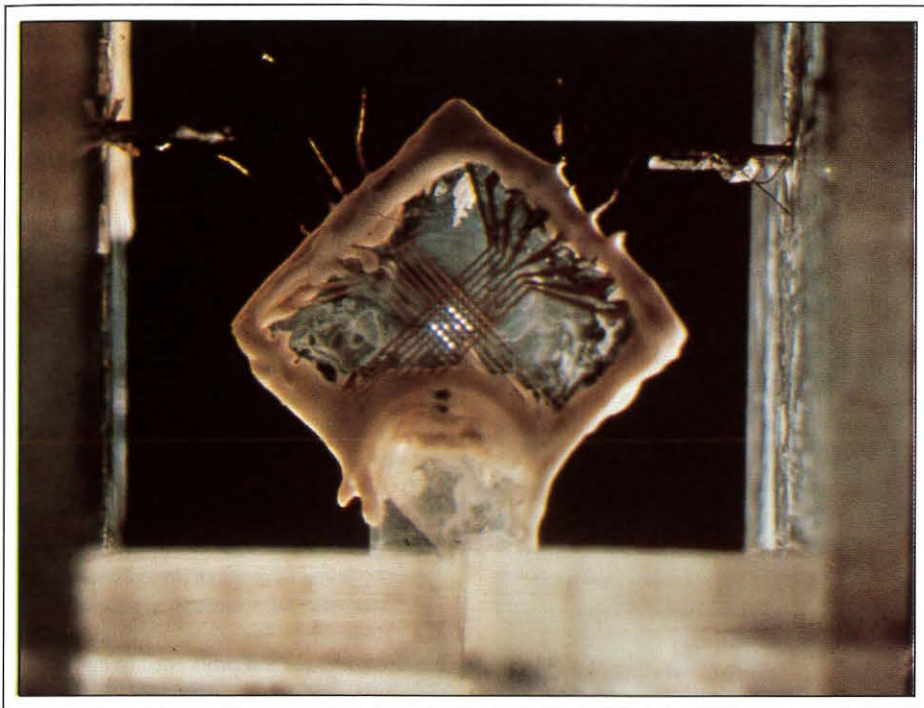

D. L. Bitzer

Fig. 3: "A lot of things have worked on a 1 x 1 matrix." This 4 x 4 panel began to convince the skeptics.

than those embodied in the display panel. Thus, part of these funds were used to expand the plasma-display program. Later, the Computer Division of ARPA provided a much larger grant specifically for further development of the plasma panel and its uses. Rome Air Development Center and the National Science Foundation provided additional support.

### The 4 x 4 Matrix Display

To drill multiple holes in the center support glass, we had to make a special drilling tool shaped like the array of cells to be made. To make the tool, our laboratory machine shop used an electrode-eroding machine to cut orthogonal slots on the tip of the drilling tool, which produced square-shaped exposed material for drilling. Thus, for the next few years all of our fabricated panels had square holes defining the array. The discharge was confined to the center of the square cell, but we had no way of constructing an open panel to study the isolation of the discharges without the center glass.

Although the first tool was made to drill an array of 8 x 8 holes, only a 4 x 4 array was used for the display. To produce this display, four gold electrodes were deposited on the

outside of the bottom and top glass plates. These glass plates were arranged so that the electrodes were orthogonal to each other, with their intersection appearing over the center 16 holes. With this panel we could now check the electrical isolation of its cells for prevention of addressing-ambiguity problems.

In order to drive the panel and sustain the selected discharges, our 500-kHz sinusoidal driver was connected to each electrode with a 100-pF capacitor. A 330-kΩ resistor was also attached to each electrode for the x-y addressing. When a bias (addressing) signal was applied to the selected x and y resistors, the bias voltage was slowly (33-μsec rise time) added to the sustainer voltage across the selected cell. That cell would fire and the addressing signal was then removed.

The addressing voltage on the selected line changed slowly compared to the sustainer frequency, allowing the cell to continue to discharge as the addressing voltage was returned to zero since the wall voltage made small adjustments at each discharge. A cell already lit along the x or y selected line remained lit for the same reason. This addressing process worked well, and we were able to demonstrate selective firing of cells which did not disturb

the state of any of the other cells. In a room filled with our electronic equipment, we were able to demonstrate this small panel writing several different characters (Fig. 3).

By this time, interest in our PDP by other researchers at the University of Illinois had begun to grow (Fig. 4). I was asked to present our results at a weekly physics seminar. At the conclusion of my talk, I was asked if I thought selective erase was possible. While answering this question, I suddenly realized the possibility of charging the wall voltage to zero by providing a fast decay of the addressing voltage at the appropriate time, causing the cell to remain off. Immediately following the seminar, Gene Slottow and I went back to our laboratory and worked all weekend building equipment and testing the idea until we had proved that selective erase would work this way.

Our original method of addressing the display was slow - 50 μsec per selection - but the high-impedance connection fit into our plans for using gas cells on the display border as selection switches.

The Plasma Display Group had expanded from three to seven researchers. In early 1967, we built a new pulse sustainer using

68 THE MINNEAPOLIS STAR Tues., Jan. 31, 1967

## 'Vision Plate' May Replace Television

By RICHARD LEWIS  
Chicago Daily News Service

URBANA, Ill.—A real-life version of the "vision plate" or "visiplate" of science fiction 30 years ago has made its debut as science fact at the co-ordinated science laboratory of the University of Illinois.

It is a flat glass panel, no thicker than window glass, which displays electronic images in black and white or in full color.

The inventors of the visiplate are Associate Prof. Donald L. Bitzer and H. Gene Slottow, a senior researcher, both electrical engineers.

They call the invention a plasma display panel. It represents a revolutionary way of producing an illuminated image by means of an electrified gas, which physicists call a "plasma."

In the plasma panel, the image can be made 30 times brighter than the conventional cathode-ray (TV) picture tube, the inventors say.

**Device for TV**

They suggest that one day glass panels using this prin-

panel exists in the co-ordinated science laboratory as a wafer-like plate about one inch square, with a tiny grid or screen only two-tenths of an inch square. Yet, the inventors can flash brilliant letters on the tiny screen.

**First Test**

At this stage of its development, the panel might not impress the layman with its potential for revolutionizing video communications. But engineers from American electronic firms are watching its development.

The first application of plasma display is the construction of 14-inch-by-14-inch-square vision panels for the university's pioneer teaching machine system, called PLATO.

PLATO (programmed logic for automatic teaching operations) consists of a high-speed, digital computer, which is the teacher, and 32 student stations. It gives credit courses in engineering, library science and nursing.

The students talk to the

Minneapolis Star

Fig. 4: By early 1967, the general press was fueling the PDP excitement.

## PDP history

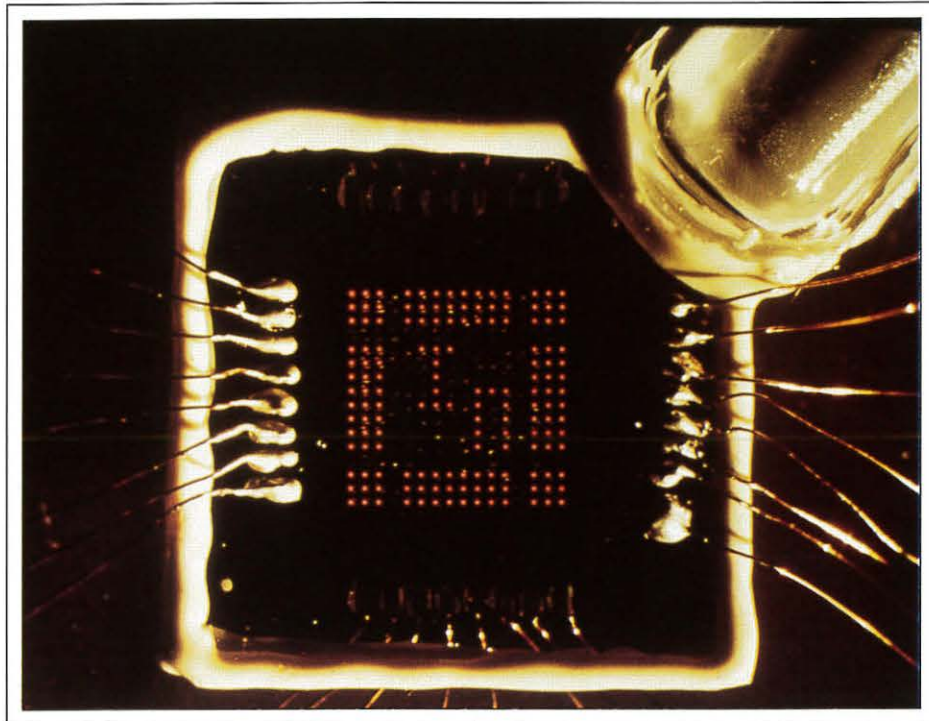

D. L. Bitzer

*Fig. 5: Improvements in sustainer designs and address-selecting electronics in 1967 permitted the construction of a 16 × 16 panel with our 1 × 1-in. microscope cover slides.*

transistors and a pulse transformer. This sustainer generated signals as large as 1500 V with rise and fall times of 1  $\mu$ sec. We were now able to use neon-argon mixtures for our display panels that exhibited good memory margins with a much lower firing voltage.

The group was investigating two other important research areas at this time. The first was related to studying reliability problems that occurred when selectively writing a cell on a completely dark panel. This problem was thought to be caused by the lack of a free electron in the cell gas at the time the write pulse was applied. This suspicion was verified when the problem disappeared if a flash strobe was synchronized to flash at the write time, providing initial electrons for the discharge.

Various schemes were developed to provide the electrons. One successful method consisted of providing border cells that lit during the write cycle. Lighting these border cells proved sufficient to supply starting electrons across 12 × 12-in. panels. Another successful technique consisted of providing a sustainer waveform that supported two ON states. One ON state was excited every sustained pulse and the other state excited every

tenth pulse. The OFF state was the dim state and the cells could be addressed to change between the states. With a view toward generating a panel with a gray scale, further research was conducted to determine how many different stable states could be supported by utilizing special sustainer signals. Generating more than a few states turned out to be difficult.

The second area of research consisted of exploring the use of phosphors for producing color displays. In early 1967, we built a panel with three cells, two of which had phosphors of two different colors deposited on the inside of the top glass plate. The third cell was left without a phosphor coating in order to observe the color of the discharge. The panels were filled with krypton or xenon to test the excitation of the phosphors, memory margin, and visibility of the gas discharge. Both gases exhibited satisfactory memory margin, but xenon appeared to produce the maximum light output from the phosphors.

The improvements in sustainer designs and address-selecting electronics in 1967 allowed us to construct a 16 × 16-cell panel with our 1 × 1-in. microscope cover slides (Fig. 5).

The equipment was small – about the size of a suitcase – compared to the 10 × 10-ft. room of equipment first used to drive the 4 × 4 panel. This small package allowed us to demonstrate the panel away from the laboratory. The 16 × 16 panel received the Industrial Research 100 award in 1968. Word soon spread through the display industry that a working flat-panel gas-discharge display that exhibited memory had been built, and interest from the display industry began to increase.

### Other Important Contributions

After 1967 many important developments took place both within CSL and in laboratories outside the University of Illinois. The CSL Quarterly Progress Reports from 1963 to 1967 list the people within the University of Illinois who contributed to the panel's development. Some of my and Gene Slottow's Ph.D. students, who worked on the plasma panel, later supervised their own students in this area, and several proceeded to develop their own companies for constructing and marketing plasma displays. Among the best known of these students are Larry Weber, now President of Plasmaco, a subsidiary of Matsushita, and Roger Johnson, CEO of Information Technology Limited.

Industrial laboratories became involved in PDP development after 1967. These included Owens Illinois Glass and IBM in the U.S.A.,



Owens Illinois Glass

*Fig. 6: Owens Illinois Glass was one of the first commercial companies to extend the development of plasma displays.*

and Fujitsu in Japan, thanks to the cooperation of Professor Heiju Uchiike at Hiroshima University, who spent a year at our laboratory, as did Dr. Kunio Ando of Hitachi (Fig. 6).

Hundreds of researchers from industry visited us at CSL, and a few stayed for a year or more to participate in our research program. Even though the panel is of simple construction, manufacturing the panel and its electronics is a high-technology operation that requires great skill. Open-matrix construction, dielectric coatings to increase life expectancy, variations in electrode configurations, new driving circuitry, color, and improvements in the manufacturing process are some of the many contributions made by these laboratories. It is the creativity and dedication of these researchers, combined with the equally important support of their corporations, that has brought the ACPDP and its brilliant display characteristics to the marketplace today. ■

### Internet Consulting and Database Research

Get on the "Net." Training, lectures, Web sites, and consulting by the former Executive Director of the Internet Society. Visit the SID homepage at

<http://www.sid.org>

Database research. Patent Searches, Technical Literature, Competitive Analysis, Market Research, Demographics

**H.L. Funk Consulting**  
7 Diane Court  
Katonah, NY 10536  
Telephone/Fax: 914-232-3530  
E-mail:  
[consult@hlfunk.com](mailto:consult@hlfunk.com)

Circle no. 14

## 300MHz Video Test Generator



### Unigraf VTG-1300

High-performance Video Test Generator on a board

As the other Unigraf video test generators, VTG-1300 comes loaded with features and backed by extensive software support

- Pixel frequency up to 300 MHz
- Fully programmable
- Fast bitmap patterns
- 255 colours, 16.7 million shades
- 2k x 2k x 8 VRAM
- DDC1 and DDC2 support
- Very fast software response
- Full ATE support

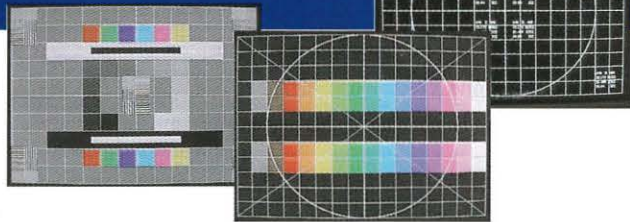

VTG-1300 is the latest addition to the family of High-performance Video Test Generators from Unigraf. The 300 MHz pixel frequency enables 1800 x 1440 display resolution at 85 Hz and above. Fast software response makes the VTG-1300 an ideal choice for ATE systems. It is full of features like DDC1/DDC2, fast bitmap patterns, 255 simultaneous colours and a powerful software support for both DOS and Windows including drivers for Windows 95 & NT 4.0.

 **UNIGRAF**  
ISO 9001 CERTIFICATED FIRM

UNIGRAF Oy, Ruukintie 18  
FIN-02320 Espoo  
Finland  
Tel. +358 9 802 7641  
Fax + 358 9 802 6699  
<http://www.unigraf.fi>

Circle no. 15

# Advancements in Plasma Panels

*PDP sales are on the rise as manufacturers work to improve the picture quality while lowering prices.*

by Shigeo Mikoshiba

**L**ARGE (42–50-in. diagonal) plasma-display panels (PDPs) are already competing effectively against cathode-ray-tube (CRT) and liquid-crystal (LC) projectors for presentation and entertainment applications, in spite of their \$10,000–15,000 price range. Seven different manufacturers have such panels in wide-VGA format (16:9 aspect ratio), which are primarily used in business settings such as airports, shopping malls, and conference rooms. Larger panels with higher resolutions are under development (Table 1).

PDP technology still needs improvement to compete more widely. While the problem of motion artifacts has already been addressed with a number of techniques, additional improvement is needed for brighter images, greater contrast, and, crucially, lower cost.

There are three major strategies for reducing the cost of PDP drivers: lower operating voltage, lower peak current, and a reduced number of high-voltage drivers (and connections).

### Address-Display Separation Scheme

A PDP emits light when a discharge occurs between two electrodes within a display cell. There are two essential types of charges involved in this process. Wall charges build up on the interior walls of the cells, and

space charges build up in the space within the cell. The space charge facilitates the discharge across the gap between the electrodes.

Most of the three-electrode surface-discharge ACPDPs rely on the address-display-period separation (ADS) driving scheme in which an addressing period is followed by the display period of each cell (Fig. 1). In Step 1 of the address period, a positive pulse is applied to horizontally running sustain electrodes (X electrodes) to erase the image of the previous field, if any. Step 2 turns on all the discharge cells in order to obtain an identical initial condition of wall charges for

all the cells, which are then turned off in Step 3.

At this time, positive and negative wall charges are accumulated on the address and Y electrodes, respectively. These charges reduce the voltage required to initiate the address discharges in Step 4. A typical address voltage is 50 V. The reduction of the address voltage is especially important because the number of columns is large. The address discharges again accumulate positive and negative wall charges on Y and X electrodes. In the following display period, sustain pulses maintain the display discharges.

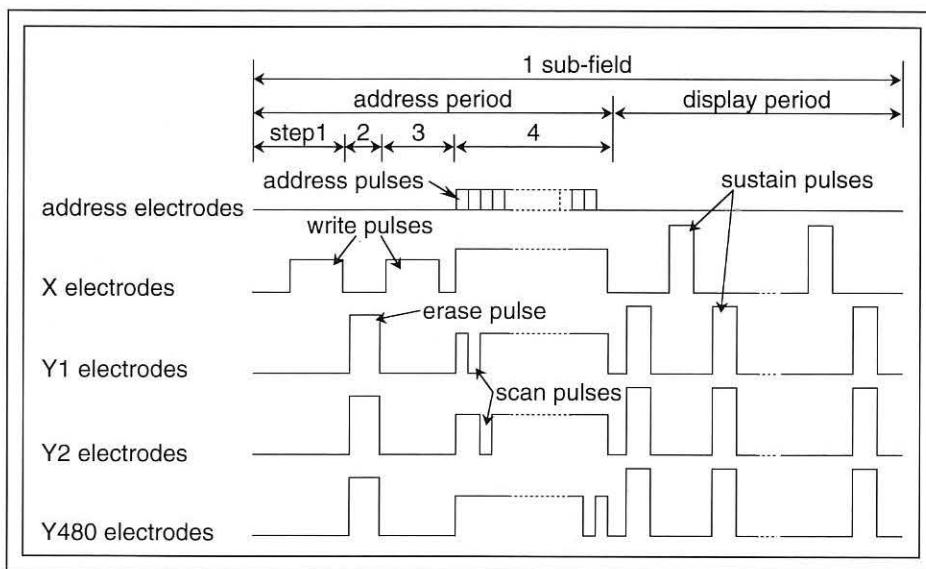

**Fig. 1:** The address–display separation (ADS) scheme uses drive-voltage waveforms with an address period followed by a display period. [Figure from K. Yoshikawa et al., Proc. of the 12th Intl. Display Research Conf. (Japan Display '92) Digest of Technical Papers, 605 (1992).]

*Shigeo Mikoshiba is a noted PDP designer and professor in the Department of Electronic Engineering, The University of Electro-Communications, 1-5-1 Chofu-ga-oka; Chofu, Tokyo 182, Japan; telephone/fax +81-424-83-3294. He is the Regional Associate Editor for Asia for Information Display.*

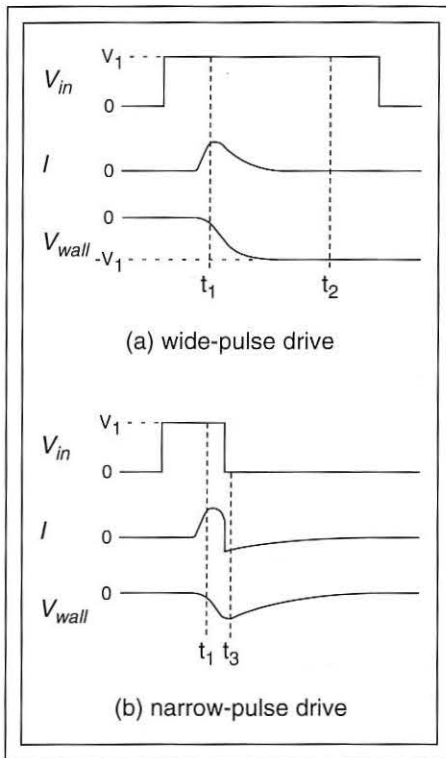

Fig. 2: The accumulated wall charge differs with wide and narrow pulse drives.

### Reduction of Drive Voltage and Current

The magnitude of the wall charges can be controlled by the length of the charging time (Fig. 2). If the cell is driven with a wide pulse - one of relatively long duration - then these charges accumulate during the discharge until they equal the input voltage. If driven with a narrow pulse - one of relatively short duration - then space charges persist after the discharge and neutralize the wall charges.

Space charges also have a priming effect. This means that as space charges accumulate, the voltage required to initiate a discharge is reduced, and a shorter discharge build-up time is required (Fig. 3).

Through the effective use of the wall and space charges, the voltage required to create and sustain a discharge can be reduced.

### Lower Peak Current

The peak current from the high-voltage driver for a PDP cell is often affected by the displacement current that flows into the stray capacitance of the panel. One way to address this is to reduce the stray capacitance through

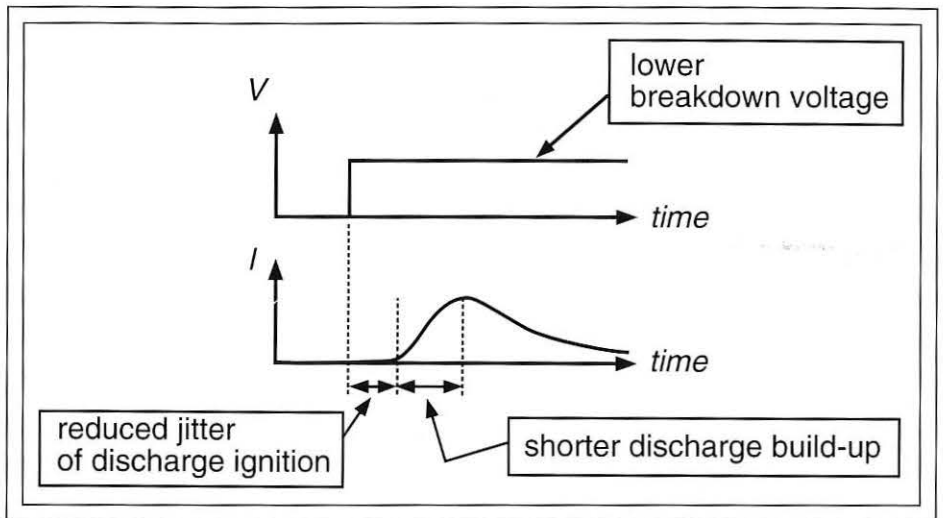

Fig. 3: The priming effect of space charges can reduce the voltage required to initiate a discharge.

the use of modified panel structures and materials. There is an alternative approach, however, that can work with existing designs. By slowing the rise and fall of the voltage pulses, the peak-current requirements are also lowered because the peak current is proportional to the derivative of the pulse voltage with respect to time. This approach requires a

panel-addressing scheme that does not require fast pulses.

### Reduced Driver and Connection Counts

Traditional PDP design calls for a circuit driver for each electrode. The number of required drivers - and the number of electrical

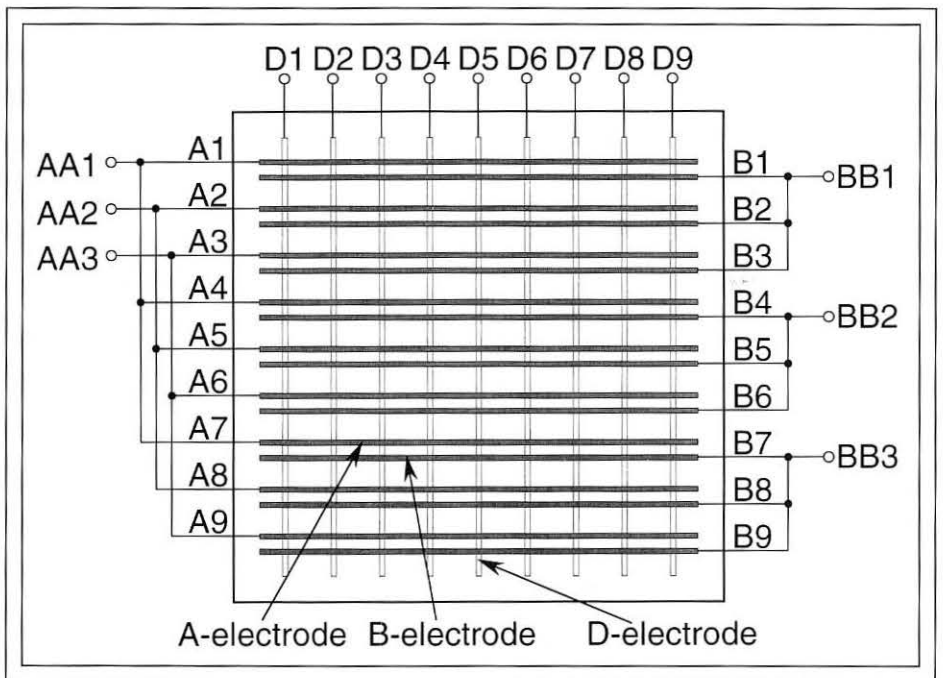

Fig. 4: The AND logic of PDP cells allows the connection of A and B electrodes to common terminals, reducing the number of high-voltage scan drivers required by the panel.

# PDP design

**Table 1: Specifications and Performance of Various PDPs**

AC/DC	Screen Size diagonal (in.)	hor. × vert. (mm)	Aspect Ratio hor.:vert. format	No. of Pixels hor. × vert.	Pixel Pitch hor. × vert. (mm)	No. of Discharge Cells hor. × vert.	Cell Pitch hor. × vert. (mm)	Luminance (white peak) (cd/m <sup>2</sup> )	Contrast (dark room) (bright)	Power		Viewing Angle (°)	Weight		Set Thickness (mm)	Comment	
										No. of Gray Levels	Consumption (W) overall panel		overall panel	overall panel			
NEC	AC	50	16:9	1106	0.81	4095	0.27	200	300:1	256	700	—	160	63	29	97	HDTV with color filter
				× 622	× 768	× 768	× 0.81										
Mitsubishi	AC	46	16:9	1012	1.189	2556	0.396	500	500:1	256	450	300	160	—	29	75	Soda-lime glass
				× 570	× 480	× 480	× 1.189										
Pioneer	AC	50	16:9	1098	0.858	3840	0.286	350	—	256	495	—	160	42	—	98	HDTV
				× 620	× 768	× 768	× 0.808										
Fujitsu	AC	42	16:9	922	0.90	3072	0.30	500	250:1	256	—	250	—	—	—	—	ALiS HDTV 1024i (interlaced)
				× 522	× 1024	× 1024	× 0.51										
Matsushita	AC	42	16:9	922	0.48	5760	0.16	450	300:1	256	—	—	—	—	—	—	Full-spec HDTV 1080p (progressive)
				× 518	× 1080	× 1080	× 0.48										
LG	AC	60	16:9	1330	0.978	4080	0.325	280	100:1	256	—	700	160	—	40	—	HDTV
				× 753	× 768	× 768	× 0.978										
Samsung	AC	50	16:9	1100	0.858	3840	0.286	350	300:1	256	550	—	160	45	—	99	HDTV
				× 620	× 768	× 768	× 0.808										
Sony	PALC	42	16:9	932.6	1.092	2562	0.364	500	—	256	—	—	140	—	—	—	ASM-mode TN-mode
				× 524.2	× 480	× 480	× 1.092										

connections they demand - can be greatly reduced using AND logic in addressing the cells, which in turn can result in a significant reduction in component costs. This effect relies on the strong non-linearity of discharge current with respect to the voltage.

Using the AND logic, every *n*th A electrode is connected to a common terminal, while all *n* B electrodes in sequence are connected to a common terminal. Drivers are only required at these terminals, reducing the number of drivers required.

In a 9 × 9-pixel array, nine A electrodes (A1-A9) and nine pairing B electrodes (B1-B9) run parallel to one another horizontally in the panel, and connect to AA1-AA3 and BB1-BB3 terminals. The nine data electrodes (D1-D9) run vertically (Fig. 4).

When operating the panel, five kinds of discharges are produced in three periods (Fig. 5). A reset discharge is established between the A and B electrodes during the reset period to initialize the wall-charge condition. In the following scan/address period, a scan discharge is established between one of the A-B electrode pairs. This discharge produces space

and wall charges in the discharge cell. The wall charges are then neutralized with a narrow wall-charge-erase pulse.

Immediately after the wall-charge-erase pulse, a data pulse is applied to the D electrode, provided that the discharge cell is to be selected for an image expression. The data pulse is adjusted so that the address discharge takes place only when the space charges exist. The address discharge accumulates new wall charges to control a display discharge that takes place between the A-B electrode pairs during the display period.

Using this technique, the number of the scan drivers can be reduced from 481 to 44 for a display of NTSC resolution - a 91% reduction - and from 1081 to just 66 for HDTV formats - a 94% reduction.

### Improved Image Contrast

Although the performance of today's PDPs is acceptable for home TV, there still remain issues to be solved. The most serious of these is insufficient contrast ratio under ambient light. Increase in the contrast can be attained by (1) increasing emission intensity from the

display discharges, (2) minimizing background light by reducing light from the control discharges, and (3) reducing reflected ambient light by the use of color filters, polarizing filters, or neutral-density filters. When using the filters, associated luminance reduction has to be compensated for by increasing the lumi-

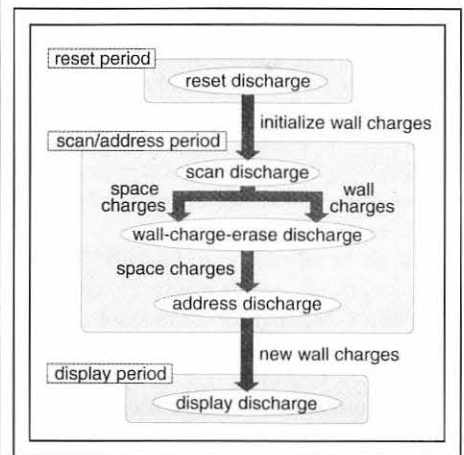

**Fig. 5: Five types of discharges in three periods are required to display a TV sub-field.**



nance of the display discharges further.

One key to improving contrast is to increase the amount of light emitted by the panel. Using the standard ADS scheme, the light-emission duty factor is only about 30%, limiting the peak luminance. The duty factor can be increased to more than 90% - resulting in three times the luminance - through the use of an address-while-display scheme. This approach allows for longer display periods because the cells can be set to display at the same time that the address scans occur. After a predetermined period, the display discharge is terminated by applying an erase pulse.

Our goal is to enhance PDP performance while bringing the price of a large-screen PDP TV receiver down to \$2000. That goal can and will be achieved over the next several years. ■

# 16

**99**

## MAY

*SID '99*

*SAN JOSE, CALIFORNIA  
MAY 16-21, 1999*

- SID's MAJOR ANNUAL EVENT
- An International Symposium, Seminar, and Exhibition - Featuring:
  - Technical Sessions - Poster Session
  - Author Interviews - Evening Panels
  - Short Courses - Applications Seminars
  - Technical Seminars - Applications Sessions
  - Product Exhibits - Display Technology Showcase

# SID '99

**Symposium, Seminar,  
and Exhibition**

**San Jose, California  
San Jose Convention Center  
May 16-21, 1999**

# 6

**99**

## SEPTEMBER

*19th International Display  
Research Conference  
(Euro Display '99)*

*BERLIN, GERMANY  
SEPTEMBER 6-9, 1999*

- An international conference on display research and development aspects of:
  - Display Fundamentals, Display Devices,
  - Hard Copy & Storage, Input Systems,
  - Integrated Devices and Applications,
  - Image and Signal Processing,
  - Color Perception, Human Factors

# 8

**99**

## NOVEMBER

*Fifth International  
Conference on the Science  
and Technology of  
Display Phosphors*

*SAN DIEGO, CALIFORNIA  
NOVEMBER 8-10, 1999*

- An international conference on the future prospects of phosphors for:
  - OLEDs - ELDs - FEDs
  - CRTs - Plasma Displays
  - PL Devices - LC Backlights

*Please send new product releases or news items to Information Display, c/o Palisades Institute for Research Services, Inc., 411 Lafayette Street, 2nd Floor, New York, NY 10003.*



### Touch Screens

The most powerful man-machine interface since advent of the keyboard and the mouse. Harness this power to your advantage; improve your products by making them easier to use.

It's that simple!

Get in touch with CyberTouch.



## CyberTouch

Touch Screens • Touch Monitors • Touch Systems

805.499.5000 • Fax 805.499.5888

sales@cybertouchusa.com  
www.cybertouchusa.com

# The View from Madrid

*The Third Ibero-American Workshop on LCD Technology combined some well-known faces with a distinctive point of view.*

by Ken Werner

**T**HE Ibero-American Workshops on LCD Technology combine short courses intended primarily for students and engineers from companies interested in using displays with a research-oriented conference that usually incorporates some non-display-related liquid-crystal (LC) research. The workshops are sponsored by CYTED (The Ibero-American Program for Science and Technology for Development) and are intended to stimulate display development and applications in Ibero-America - virtually everything in the Western Hemisphere south of Texas - as well as encourage continuing dialogue between the Ibero-American countries, Spain, and Portugal.

The third of these workshops was held at the Polytechnic University of Madrid in Madrid, Spain, September 26-28, 1998, with the short courses held September 22-24.

## Short-Course Highlights

The short courses were organized primarily by Alaide Pellegrini Mammana (Centro Tecnológico para Informática, Campinas, Brazil) and Cristina da Mata Quintella (Universidade Federal da Bahia (Bahia, Brazil)). The contingent of non-academic engineers expected from Ibero-America did not materialize at the short course, victims of the economic crisis that was rapidly developing in Brazil at the time, but 22 students (mostly from Brazil) somehow managed to come.

One of the half-dozen short-course presenters, Valentin A. Tsvetkov (formerly of the

Moscow State Academy of Instrument Engineering and Informatics), described a 300 × 300-mm panel that uses liquid crystal in dynamic scattering mode (DSM) to simulate fog for the training of aircraft pilots. The panel is placed in the pilot's line of sight and is transparent in its undriven state. An instructor can energize the panel at any time, simulating sudden fog or haze. DSM was chosen, said Tsvetkov, because for safety reasons the panel must become clear in the event of a power interruption. The device replaces a textured polymer sheet that was inserted in the pilot's line of sight mechanically. Fifty units are in use at Ilyushin Aircraft, and pilot feedback is favorable.

Tsvetkov is now working for a private company and developing very inexpensive LC displays (LCDs) to be used in computers for children. He also mentioned the poster paper he delivered at Asia Display in Seoul, in which, when energized, two comb-like electrodes create diffraction gratings of two different pitches in an LC layer, creating an efficient two-color-plus-black display that does not require polarizers or color matrix filters.

Maria del Carmen Pina Luis of the University of Havana (Havana, Cuba) presented a tutorial introduction to the characteristics and compounding of LC materials. Along the way, she presented a detailed history of LC research and development, and concluded with a discussion of LCs in biological structure and function. Included in her history was a quote from F. C. Frank to the effect that all the important questions concerning liquid crystals had been answered. The year was 1958.

The spirit at the short course was lively, friendly, and informal. With the help of Prof. Carmen Pina Luis, who speaks both Spanish and Russian, it was found that by using the linguistic talents of the presenters and the audience members, questions and answers could be translated between any two of the languages spoken.

## The Workshop

The workshop was organized primarily by the local organizing committee - José Antonio Martín-Pereda (Workshop Coordinator) and José M. Otón (Program Coordinator) and their colleagues at the Polytechnic University of Madrid.

On the technical program's first day, a series of invited papers began with a talk by Eugenio Cortés (SPECOS, Madrid), who was described by session chair Manuel Lopez-Amo y Sáinz as arguably Spain's leading LC researcher. (Cortés was one of the founders of the Spanish LCD company Dicryl.) His paper, "The Art of Manufacturing Liquid Crystal Displays," outlined the LCD-manufacturing sequence based on Dicryl operations, and went on to describe the various LCD technologies being used today. One of his interesting observations: 50% of the cost of small TN and STN displays is in the polarizers. In answer to a question from Alaide Mammana, Cortés said, "A small company like Dicryl can make a good business working in niche markets, but marketing is difficult."

In "Charge Injection-Driven Nematic Bistable Pixel with Gray Scale," Michèle Giocondo (Istituto Nazionale di Fisica della

---

Ken Werner is the editor of Information Display Magazine.

Materia, Cosenza, Italy) described and demonstrated an enhancement to the fast-responding bistable nematic pixels that have been developed over the last few years. The new pixel switches between a uniform hybrid texture and a non-uniform one in which the creation of a surface-wall defect network is governed by a polar electrohydrodynamic instability. The uniform hybrid texture is restored by breaking the surface anchoring with a short electric pulse with amplitude slightly larger than  $8 \text{ V}/\mu\text{m}$ . The anchoring surface is created with an oblique application of  $\text{SiO}_2$ ; the write time is about 100 ms and the erase time is about 1 ms. Gray scale is possible through modulation of the defect density.

Wolfgang Haase (Darmstadt University of Technology) asked how long the described pixels have been functioning, to which Giocondo answered, "Three years, on and off."

Ernst Lueder (University of Stuttgart) gave an invited talk, "Liquid Crystal Displays with Plastic Substrates." The benefits of plastic substrates are clear. They are one-sixth the weight of glass, unbreakable, and can be bent and twisted - desirable for styling purposes in applications such as automobile dashboards.

But there are challenges. Plastic substrates must be inexpensive and stable up to  $150^\circ\text{C}$ , and must have low permeation to  $\text{H}_2\text{O}$  and  $\text{O}_2$ . To keep the permeation down, barrier layers are needed. Two  $50\text{-}\mu\text{m}$  barrier layers of  $\text{TaO}_5$  on a PES substrate is a very effective solution. Another problem is that appropriate plastic substrates undergo compaction - they shrink - during display processing, but compaction can be reduced dramatically by annealing the substrate at  $100\text{-}150^\circ\text{C}$  before use.

An excellent application for plastic-display technology is building a display into a Smart Card so the balance on the card, for example, can be checked at any time. Such cards have been made and work well.

Plastic substrates have also been used with low-temperature PECVD procedures to make amorphous-silicon (a-Si) TFT arrays that serve as light-sensing arrays when an a-Si light sensor replaces each LCD pixel in the array. The team at Stuttgart has built a  $96 \times 128$  imager. (Since the substrate bends, the imager can look to the sides as well as ahead.)

Lueder said his dream was to use plastic-substrate technology to make a surface-stabilized FLC A4-size e-book display that is sunlight-readable at the beach.

In "Universal Computer Modeling System of LCDs: MOUSE-LCD," Vladimir Chigrinov (Shubnikov Institute of Crystallography, Moscow) described and demonstrated a new LC electro-optics simulation module that is based on two programs. The first calculates any LC director distribution with arbitrary director twist and any director tilts on the boundaries. The second program calculates the optics of anisotropic media with variable axis of the optical tensor. The calculations are based on basic physical principles and the module is powerful. It can, for instance, calculate transmission-voltage characteristics and isocontrast curves. It "predicts" the formation of parasitic stripes in STN-LCDs and also "predicts" that increased tilt angle fixes the problem. ("Predicts" is in quotes because this is one of the classic results of STN-LCD design.) The module works at acceptable speed on a 133-MHz PC, and a demo copy is available.

In "Polymer Dispersed Liquid Crystals for Electro-Optical Devices," Alfredo Strigassi (Politecnico di Torino) reviewed the operation and design parameters of PDLCs, discussed the effects that various dopants can have on device characteristics, and previewed possible research directions.

Giancarlo Abbate (Università di Napoli Federico II, Napoli) discussed non-linear optical phenomena in LCs, with emphasis on second-harmonic generation (SHG). The field of non-linear optics (NLO) of LCs started in the early '80s. Fundamental work can be done in small labs with small budgets, and interesting applications are likely in the future.

In a special invited address, Norbert Chien of InfoCast LLC demonstrated his eTEAM software for collaborative communications. An eTEAM user can easily take a "snapshot" of anything on his monitor screen, which brings the object into eTEAM. The user can then use pens and other drawing tools to mark portions of the image and verbally comment on what he is designating. A click on the mail icon automatically sends the communication as an e-mail attachment using the user's normal e-mail client. When the recipient opens the attachment, he or she sees the image selected by the sender, and then hears the sender's voice comments synchronized with the markings on the image. The recipient can then make further comments and markings (in a different pen color, if desired) and send it back or on to another party.

The sorts of "images" that can be annotated are text documents, photographs, design layouts, schematic drawings, spreadsheets, and architect's renderings. Most of eTEAM's clients are corporations, but members of the mostly academic audience at the workshop saw substantial applications in collaborative research and computer-mediated education.

The day's program finished off with a Global Cooperation Roundtable. Carlos Mammana (CTI, Campinas, Brazil), reporting on a recent Latin American conference on the problems of globalization, concluded that "Globalization tends to concentrate resources, not distribute them." Mammana reported that the conference also addressed the difficulties of cooperation within a competitive framework.

Ken Werner (*Information Display Magazine*) responded by describing the model of the United States Display Consortium (USDC) as an example of cooperation within a competitive framework, and praised USDC's practice of having the user community define the research goals that are incorporated into RFPs. Then, the ensuing research proposals are reasonably well assured of addressing problems that the user community wants to have solved. This coupling of research and applications is not included in many research-funding mechanisms, with the result that money is spent to find answers to questions that do not have wide application.

On the second day, Alan Mosley (CRL, U.K.) delivered an invited paper entitled "Miniature Liquid Crystal Displays." Microdisplays are of two kinds: polysilicon TFT-LCD and chip-based, which includes liquid-crystal-on-silicon (LCOS) displays. Polysilicon displays are now quite widely used in projectors, while the only chip-based display in wide use is TI's DMD. But LCOS is going to grow rapidly. If the estimate of Three Five Systems that 20% of mobile telephones will have a built-in viewer by 2005 is correct, that means the viewer market alone will grow from zero in 1997 to \$1 billion in 2005. LCOS displays will also be used in business projectors, rear-projection monitors and TV receivers, and binocular headsets.

Mosley reviewed the various kinds of microdisplays, recent developments, and the current state of the art. He reviewed in detail the different LC modes that can be used in LCOS displays, and concluded that the *only* microdisplay technology that can be success-

## ANNOUNCING A BREAKTHROUGH IN VIDEO TEST GENERATORS...



### LOW PRICE! HIGH PERFORMANCE!

#### Announcing the new 360 MHz Quantum Data 801GG Video Test Generator.

Powerful! Over 150 standard test images. Over 130 popular formats. 14 for HDTV. All pre-programmed. Plus, create your own tests easily with our included VGM™ [Video Generator Manager] software. Available as a PC plug-in for \$5,700. Or, as a standalone unit (shown) for only \$7,700. Contact Quantum Data now.



The Art of Technology

**QUANTUMDATA**

2111 Big Timber Road, Elgin, IL 60123  
Phone: (847) 888-0450 Fax: (847) 888-2802  
Website: <http://www.quantumdata.com>



Circle no. 16

# SID '99

San Jose Convention Center  
San Jose, California  
May 16–21, 1999

## conference report

fully used in a one-channel projector – a projector in which a single imager is used for all three primary colors – uses antiferroelectric LC-on-silicon with an SRAM backplane.

Ken Werner presented an invited paper describing the large-area flat-panel displays that are available today, and the technological developments that will be required to bring the price of plasma-display panels down to mass-market levels. In the following Q&A session, Yoshiharu Nakajima [Association of Super-Advanced Electronics Technologies (ASET)] commented that the Sony/Sharp/Philips plasma-addressed liquid-crystal (PALC) display shown at the recent Japan Electronics Show looked very much better than the one shown at SID in May. “PDP has a sparkling look for some people,” he said, “while the PALC had a softer look that permitted better viewing of detail.”

In “From Ferroelectric Liquid Crystals to Thresholdless Antiferroelectrics – and Back,” Sven T. Lagerwall (Chalmers University of Technology, Göteborg, Sweden) described the switching mechanisms in various ferroelectric and antiferroelectric phases and provided a (somewhat controversial) explanation of how phases are selected and spontaneously convert to other phases. Among his observations is that the so-called “thresholdless” antiferroelectric phase is actually twisted smectic.

Gennady Fiksmen (Polytechnic University of Madrid) presented the final oral paper, on LC waveguide-based fiber-optic devices. The idea is to make a simple LC cell that receives an optical fiber that terminates in the cell. Electrodes define a continuation of the fiber. Energizing the cell changes the index of refraction of the LC, which allows it to maintain the collimation of the light. If the cell is not energized, the light disperses. The next stage of device development is to make a Y-shaped channel and switch the incoming light to one of two outputs. Compared to existing optical switches, the LC switch will be slow and very inexpensive, and that combination should be a good one for many communications applications, said Fiksmen.

The oral presentations were followed by poster sessions and, on the following day, a session to plan how the organizers of the LCD workshops and the SID might cooperate more fully in the future. The next Ibero-American LCD Workshop will be held in the Western Hemisphere. There was discussion of possible sites in Brazil or Cuba. ■



**“Reports of our death have  
been greatly exaggerated!”**

**WINTRON**

WinTron Technologies delivers the next generation in deflection technology.

## **WinTron, Inc. is now WinTron Technologies, a division of Video Display Corporation.**

WinTron Technologies, providers of yokes, coils, power supplies, and flyback transformers to the display industry, is proud to announce its new association with Video Display Corporation. We will serve the industry with the same quality, reliability, and responsiveness you've come to know us for. And now we have the power of Video Display Corporation behind us!

*WinTron Technologies  
has moved to a new location!!  
614 Spearing Street  
Howard, PA 16841*

Phone: 814-625-2720  
Fax: 814-625-2725

E-mail [wintron@wintrontech.com](mailto:wintron@wintrontech.com)  
Circle no. 17



See us on the web  
[www.wintrontech.com](http://www.wintrontech.com)

# SID Conference Calendar

Next Show!

## International Symposium, Seminar & Exhibition (SID '99)

JOIN US IN SAN JOSE TO SEE AND HEAR WHAT'S NEW IN DISPLAY TECHNOLOGY.

- The Technical Program will consist of over 180 original and invited papers with 60 more in a Poster Session, all organized in six parallel tracks:
  - AMLCDs and Display Manufacturing
  - Applications and LC Technology
  - CRTs and Emissive Displays
  - Applied Vision, Human Factors, Display Measurement, and Display Electronics
  - Large-Area Displays and Display Systems
- The Seminar Program will once again draw on industry leaders for three days dedicated to short courses, technology overviews, and display applications.
- Over 250 vendors will demonstrate the latest in displays, components, and equipment.
- Evening Panel Discussions, an Exhibitor Reception, a Conference Luncheon, and an evening Social Event will complement the technical program.

**16** **99**  
MAY  
SID '99  
SAN JOSE, CALIFORNIA  
MAY 16-21, 1999

- SID's MAJOR ANNUAL EVENT
- An International Symposium, Seminar, and Exhibition - Featuring:
  - Technical Sessions - Poster Session
  - Author Interviews - Evening Panels
  - Short Courses - Applications Seminars
  - Technical Seminars - Applications Sessions
  - Product Exhibits - Display Technology Showcase

**6** **99**  
SEPTEMBER  
19th International Display Research Conference (Euro Display '99)  
BERLIN, GERMANY  
SEPTEMBER 6-9, 1999

- An international conference on display research and development aspects of:
  - Display Fundamentals, Display Devices,
  - Hard Copy & Storage, Input Systems,
  - Integrated Devices and Applications,
  - Image and Signal Processing,
  - Color Perception, Human Factors

**8** **99**  
NOVEMBER  
Fifth International Conference on the Science and Technology of Display Phosphors  
SAN DIEGO, CALIFORNIA  
NOVEMBER 8-10, 1999

- An international conference on the future prospects of phosphors for:
  - OLEDs - ELDs - FEDs
  - CRTs - Plasma Displays
  - PL Devices - LC Backlights

**16** **99**  
NOVEMBER  
7th Color Imaging Conference: Color Science, Engineering, Systems & Applications  
SCOTTSDALE, ARIZONA  
NOVEMBER 16-19, 1999

- An international multidisciplinary forum for dialogue on:
  - Creation and capture of Color Images
  - Color Image reproduction and interchange
- Co-sponsored with IS&T

For additional information:

Dee Dumont  
Society for Information Display  
31 East Julian Street  
San Jose, CA 95112  
408/977-1013, fax - 1531  
www.sid.org



Since 1962, a professional worldwide interdisciplinary society committed to the advancement of information display.

# Flat Panel Testing... FAST & SIMPLE!

The SS220 is the easiest and quickest way to test your flat panels! The system is portable and compact, fitting easily into your test area. No integration or mechanical fixturing is required. A simple click of the mouse and your test suite is on its way to completion, providing accurate display measurements AUTOMATICALLY!

## The SS220 Flat Panel Test System:

- Fully Automatic Off Axis Measurements
- Spectrometer Based - Luminance & Chromaticity Measurements
- Automatic Measurements to VESA, ISO 13406 & TCO 95 Standards
- Complete Turnkey System
- Panel Drive Electronics

## Measurements:

- Chromaticity vs. Viewing Angle
- Contrast vs. Viewing Angle
- Luminance & Color Uniformity
- Spectral Plots
- Contrast Ratio Plots
- Back Light Characterization
- Reflectance (BRDF)



## MICROVISION

550 High St., Auburn, CA 95603  
Tel: (530) 888-8344 Fax: (530) 888-8349  
Email: sales@microvsn.com



Visit our Website at:  
[www.microvsn.com](http://www.microvsn.com)

SOMEWHERE ON THE SPECTRUM BETWEEN EXCELLENCE AND PERFECTION...

Circle no. 18

## We See FPD Controllers From Your Point Of View

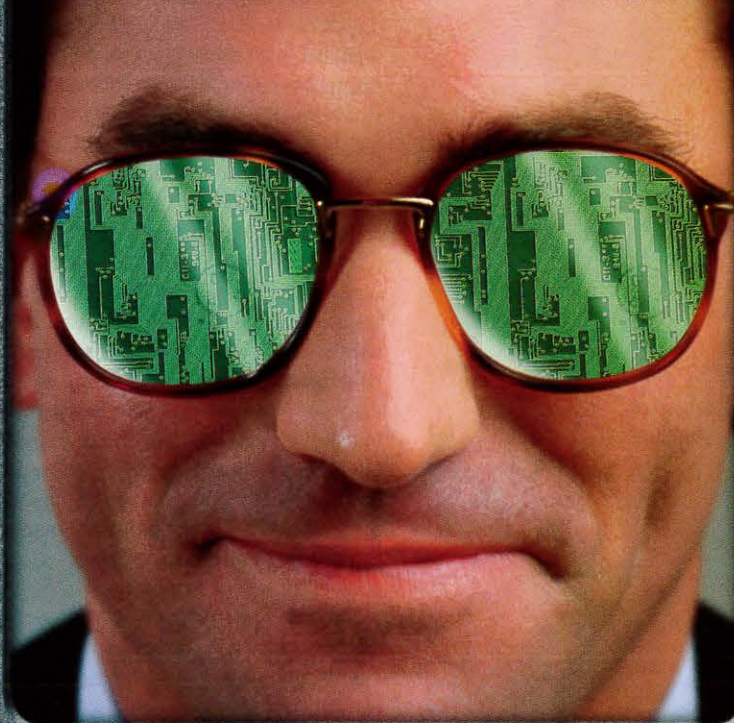

### High Quality Video, Compact Interface Solutions For VGA, SVGA, XGA LCDs

#### The LCD80xXCV Series

- 16.7M (24-bit) RGB Color Sampling
- Power Supply Sequencing
- On-Screen Display Menus Standard
- Video: NTSC, PAL, SECAM Composite & Y/C (S-Video) Support
- Supports 4-, 6-, 8-bit Displays
- Enclosures: Complete Industrial Line From 6.4-in. up

Additional High Performance Controllers Available.

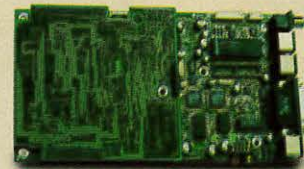

## ViewTEK

Advanced Solutions for Display Technology

**1-888-FLAT-PANEL**

<http://www.view-tek.com>

Circle no. 19

## display continuum

continued from page 4

memory? Well, maybe at least we can find some useful parts or ideas to work with. How about the idea of using the home's electrical wires to pass information? Maybe that could come in handy.

What else do we have? How about the cable-TV wires and the phone lines? Could we do something with those? With so many rooms having phone jacks and cable outlets, we have quite a network already in place.

What's that over there? Oh, you mean the Web TV? Wasn't that a strange curiosity? Who ever thought that people would want to watch their TVs from two feet away so they could surf the net?

Could we perhaps use some of that picture-phone technology sitting up there on that dusty shelf for something? It looks like once upon a time it had the capability of at least sending nice still images over phone lines.

And that audio-system control center over there. Couldn't we adapt that component-control idea in some interesting way? It always seemed pretty easy to interconnect and switch between audio components.

You know, I think all of this is beginning to jell into an interesting concept that may just be worthy of a recycling effort. Suppose we thought about a completely new way to create an electronic home? No, no, I'm not thinking of putting a display on the refrigerator or computer-controlling the toaster! Suppose we confined our electronic-home ambitions to information management only. Here's what I'm thinking. Remember that "Display Continuum" column from last December, the one in which I wrote about the "third wave" of information technology being imaging? Remember the description of a family in which everyone is doing image capture with digital cameras, or conventional cameras and scanners, then doing computer-based image manipulation, storage, and Internet transmission? Well, it seems to me that what is beginning to happen is that an increasing number of homes are ending up with several computers, two or more printers, several telephones plus a cell phone, several pagers, a fax machine, a scanner or two, and will soon have multiple digital cameras. Voice and data information are already moving back and forth on one or more of the telephone lines and will soon be coming and going on high-speed cable - today's TV cable. Within a few years, so much more data and images will be moving on these lines, compared to voice messages, that conventional telephone calls to anywhere in the world will be included in the monthly fees for data communications. In effect, voice messaging will become free.

What do you think would happen if we took all these pieces and created an information control center that is as simple to interconnect and use as an audio system? For example, let's take the telephone lines and cable lines

- ◆ ELECTRO-OPTICAL MEASUREMENTS OF DISPLAY TO CARRY OUT ?
- ◆ LIMITED BUDGET ?

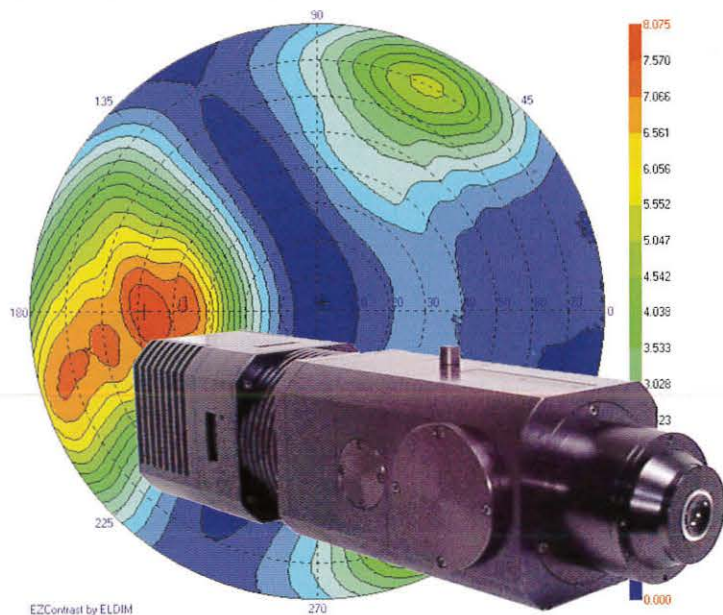

## Think About EZLITE from EZContrast Family

- > Realizes a +/- 60° Incident angle, 0-360° azimuth angle luminance measurement in **less than 5s**
- > Compatibility with main display characteristics measurement standards (ISO, VESA...).
- > Ask for detailed specifications, hardware and software options for completely automated systems !

ELECTRONICS FOR DISPLAYS AND IMAGING DEVICES

1185 rue d'Epron 14200 HEROUVILLE SAINT CLAIR - France  
Phone : + 33 2 31 94 76 00 - Fax : + 33 2 31 94 09 50  
EMail : eldim@eldim.fr - Internet address : <http://www.eldim.fr>



**ELDIM**

© ELDIM SA - 1998 / Aug0103 - V1.0

Circle no. 20



and make these the ports that access the outside world. Then, let's provide a number of connections for all the other devices, such as printers, fax machines, scanners, digital cameras and, of course, several computers. Each computer can access one or more of these devices and its companion computers. Whatever is too far away for direct connection we can access by just plugging into any wall socket and transmitting the data over the house wiring. But please, don't make me do software - make it plug and play, just like an audio system.

Haven't we just re-invented a server? Sure, if you want to call it that. But it's not like any server available today. This one is a consumer product priced at under \$1000 and is user friendly. Everything can be set with front-panel switches and knobs. The LED display panel tells me everything I need to know about how my network is configured. I don't need to do any programming or software upgrades, and the way it is designed to accept communications protocols should keep it from going obsolete for at least 10 years. And most important, it won't require the user to learn complicated software diagnostics.

Best of all, with this evolution of an in-home network, the use of displays is going to increase dramatically. It will now become practical to have interconnected displays in every room of the house. Switching between entertainment, digital image display, and Internet functions will be simple, and since the computer(s) can be placed anywhere, the concept of a dumb terminal with a high-resolution flat-panel display will finally be realized.

And so it came to pass that the third wave of information technology, based on image capture, storage, manipulation, and transmission, was facilitated by this new invention that found its first spark of life in the modest environs of the junkyard of rejected technologies. The electronic home finally became a reality, but a very different reality from that predicted for so many years by the technology futurists. And as is so typical with new ideas, this one was missed by the well-established software and hardware suppliers. It took new companies with new approaches to give it birth. Only then did the formerly dominant players scramble to catch up with belated acquisitions and mergers - and multiple changes in management.

However, true to form, the business version of the dumb terminal never successfully re-emerged from the junkyard of rejected technologies.

If you would like to join me in doing some futuristic visioning of your own in our virtual-technology junkyard, you may make inquiries regarding the sale or acquisition of whatever

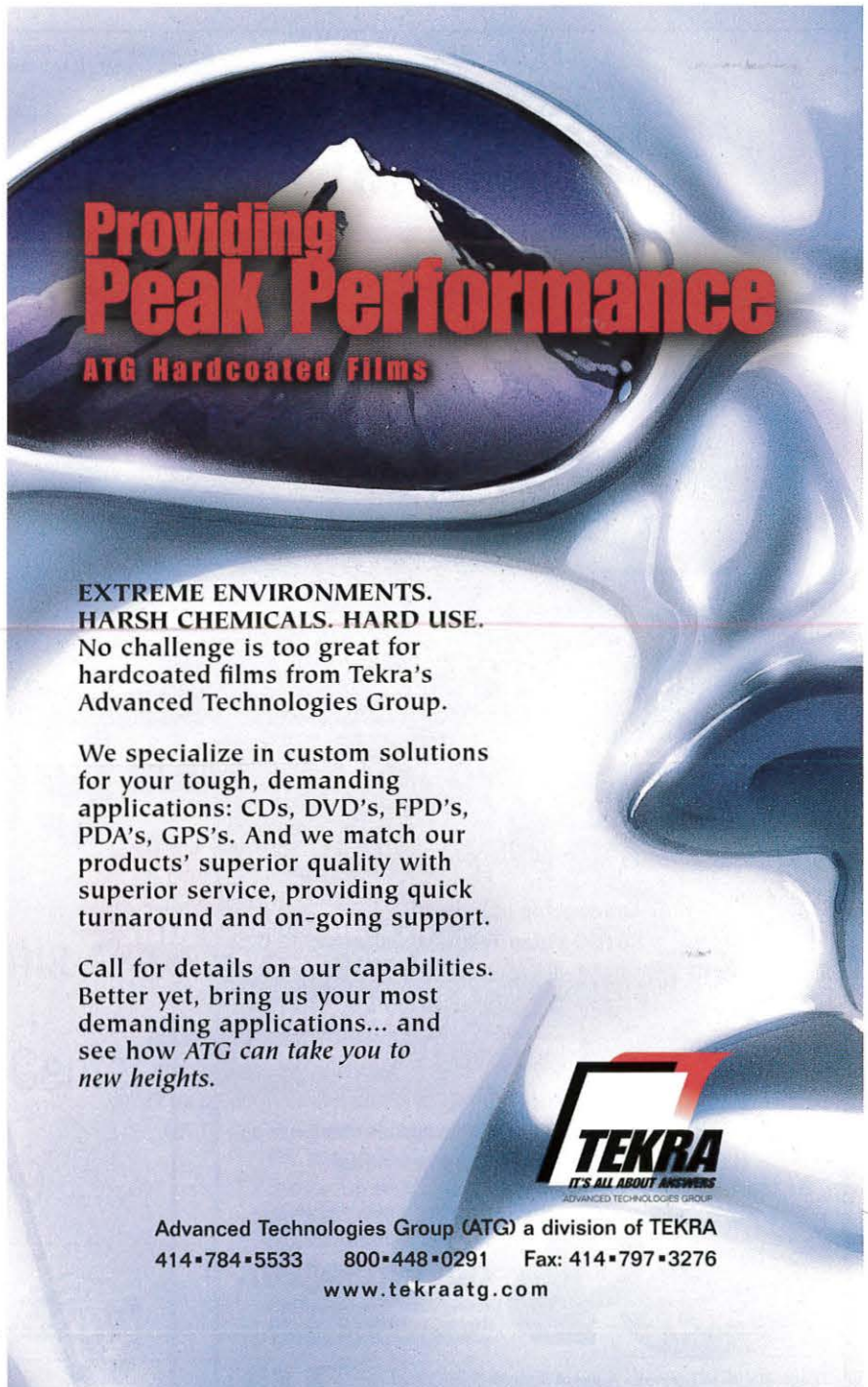

**Providing  
Peak Performance**  
ATG Hardcoated Films

**EXTREME ENVIRONMENTS.  
HARSH CHEMICALS. HARD USE.**  
No challenge is too great for  
hardcoated films from Tekra's  
Advanced Technologies Group.

We specialize in custom solutions  
for your tough, demanding  
applications: CDs, DVD's, FPD's,  
PDA's, GPS's. And we match our  
products' superior quality with  
superior service, providing quick  
turnaround and on-going support.

Call for details on our capabilities.  
Better yet, bring us your most  
demanding applications... and  
see how ATG can take you to  
new heights.



Advanced Technologies Group (ATG) a division of TEKRA  
414•784•5533 800•448•0291 Fax: 414•797•3276  
[www.tekraatg.com](http://www.tekraatg.com)

Circle no. 21

## display continuum

technology pieces interest you by contacting me via e-mail at silzars@ibm.net, by fax at 425/557-8983, by telephone at 425/557-8850, or by the never-to-go-obsolete regular mail

at 22513 S.E. 47th Place, Issaquah, WA 98029. But remember, there is a BIG differential between the selling price and the buying price. ■

## editorial

*continued from page 2*

little joystick mounted next to the on-off button provides access to the OSD and a wide range of monitor adjustments, including the moiré correction, corner-convergence adjustments, and degaussing. The user can choose from three color temperatures (5000 K, 6500 K, and 9300 K) or can individually adjust the RGB gains and biases.

Although this is not a USB monitor, Sony has built a USB hub into the base. A USB cable connects the hub to the USB port on the system unit, and USB peripherals can conveniently be plugged into the available USB ports in the base. Since one of the target markets for the GDM-F500 is graphic arts professionals, it is likely that the USB ports will be appreciated (for things like scanners and digital cameras) earlier than would be the case for general business users.

Sony wants to differentiate itself by incorporating the flat-display (FD) technology through its product line as widely as possible. A 19-in. version of the monitor being reported here was introduced at fall COMDEX for an estimated selling price of \$999, and Sony's Treg Tyler told *Information Display* that FD technology will migrate into the corporate monitor line by the end of 1999 (although perhaps not with the 0.22-mm grille pitch). And Sony will not be OEMing the FD technology. (Sony has certainly made conventional Trinitron™ monitors for the likes of Gateway and IBM, but all FD monitors will carry the Sony brand.)

FD technology is also available in the consumer market. Sony's WEGA FD TV receivers have been available in Japan for some time, and they are now available in the U.S. in several sizes.

Currently, all FD production is in Japan, but Sony San Diego will get its chance in the future, said Tyler.

It is good to see a major CRT manufacturer differentiating itself on the basis of technological expertise that is used to make an extremely attractive product. But Sony is not alone in recognizing that a CRT maker must innovate if it is to raise at least part of its product line out of the sucking ooze of the commodity swamp. CRT-based products are getting interesting again – and not only Sony's.

– Ken Werner

### WHICHEVER VIDEO TEST ENVIRONMENT YOU CHOOSE TO WORK IN...



STANDALONE

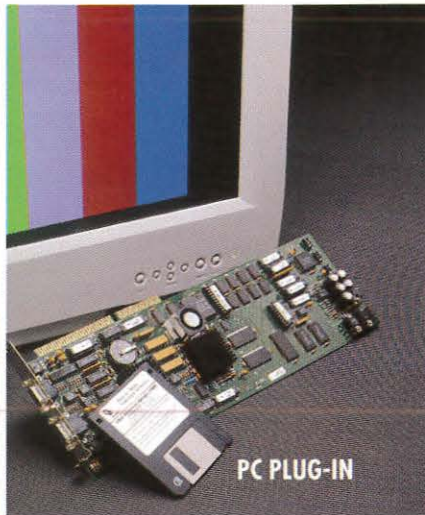

PC PLUG-IN

### ONE VIDEO TEST GENERATOR STANDS OUT FOR PRICE AND PERFORMANCE

Announcing the 360 MHz 801GG Video Test Generator.



Powerful! Over 150 standard test images. Over 130 popular formats. 14 for HDTV. All pre-programmed. Plus, create your own tests easily with our VGM [Video Generator Manager] software. The 801GG-ISA is available as a PC plug-in for \$5,700. Or the 801GG, a standalone unit, is only \$7,700. Contact Quantum Data now.



The Art of Technology

**QUANTUMDATA**

2111 Big Timber Road, Elgin, IL 60123  
Phone: (847) 888-0450 Fax: (847) 888-2802  
Website: <http://www.quantumdata.com>



Circle no. 22

# The World Leader in LCD Backlighting...

LCD Lighting, Inc. is your best source to design and manufacture miniature and sub-miniature fluorescent lamps used as replacements or original equipment for backlighting all types of LCD information displays.

Cold cathode lamps are available in standard lengths and diameters of 2.0mm to 10mm; hot cathode lamps in 8mm to 20mm.

Our ability to manufacture special multiple-bend complex lamp shapes offers unique advantages to our customers.

Most importantly, we will meet your requirements and deliver the solution. LCDL's phosphor

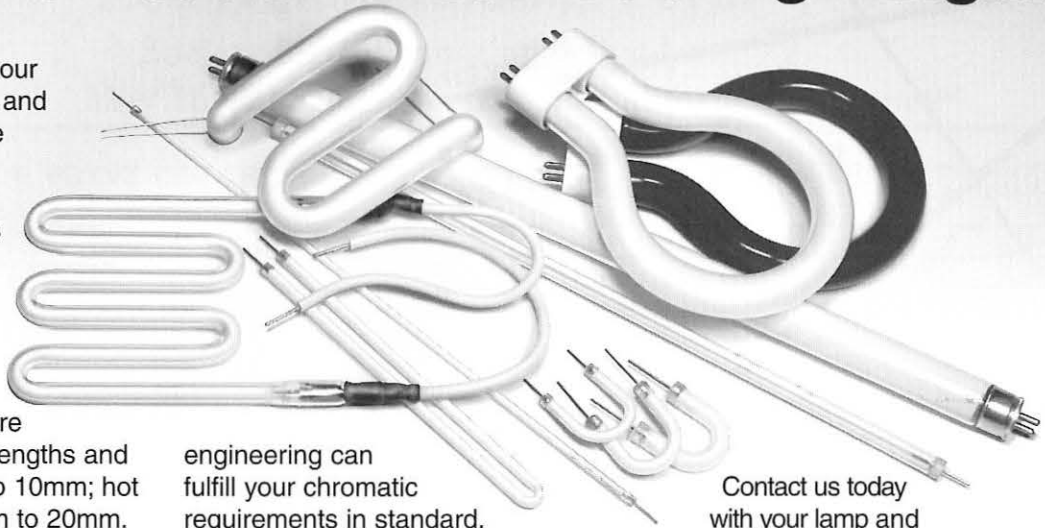

engineering can fulfill your chromatic requirements in standard, tri-band, or custom blend. Lamp design can incorporate any environmental, electrical, and dimming requirements.

We can also provide the wiring harnesses, connectors, or heater assemblies that accompany many of our lamps.

Contact us today with your lamp and lamp sub-assembly needs.

## LCD Lighting, Inc.

37 Robinson Blvd. • Orange, CT 06477  
Ph: 203 795-1520 • Fax: 203 795-2874  
[www.LCDL.com](http://www.LCDL.com)

Circle no. 23

# SID '99

San Jose, California

San Jose Convention Center

May 16-21, 1999

**Mark Your Calendar Now!**

## VIDEO REFERENCE IMAGE GENERATOR

*The V.I. Model 875A gives you the picture!*

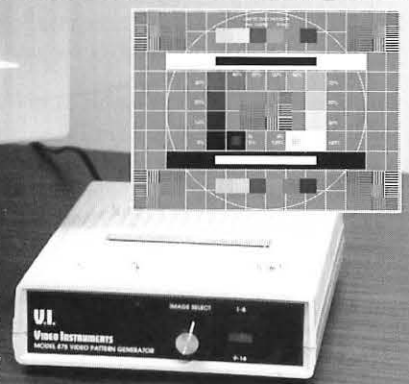

- Programmed as **you** need from your p.c. using the V.I. Image Master library.
- Stores up to 16 reference images - one pattern at 16 different rates, or 16 patterns at one rate, or any combination in between.
- Monochrome and RGB color video.
- External synchronizing pulses.
- Small, light, portable.

**Affordable \$1,695.00**

**V.I.**  
VIDEO INSTRUMENTS

2155 Bellbrook Avenue • Xenia, OH 45385-4043  
Ph.: 800-962-8905 • 937-376-4361 • Fax: 937-376-2802  
E-mail: [sales@videoinstruments.com](mailto:sales@videoinstruments.com)  
Visit our Web Site: [www.videoinstruments.com](http://www.videoinstruments.com)  
Visa • Mastercard • American Express

Circle no. 24

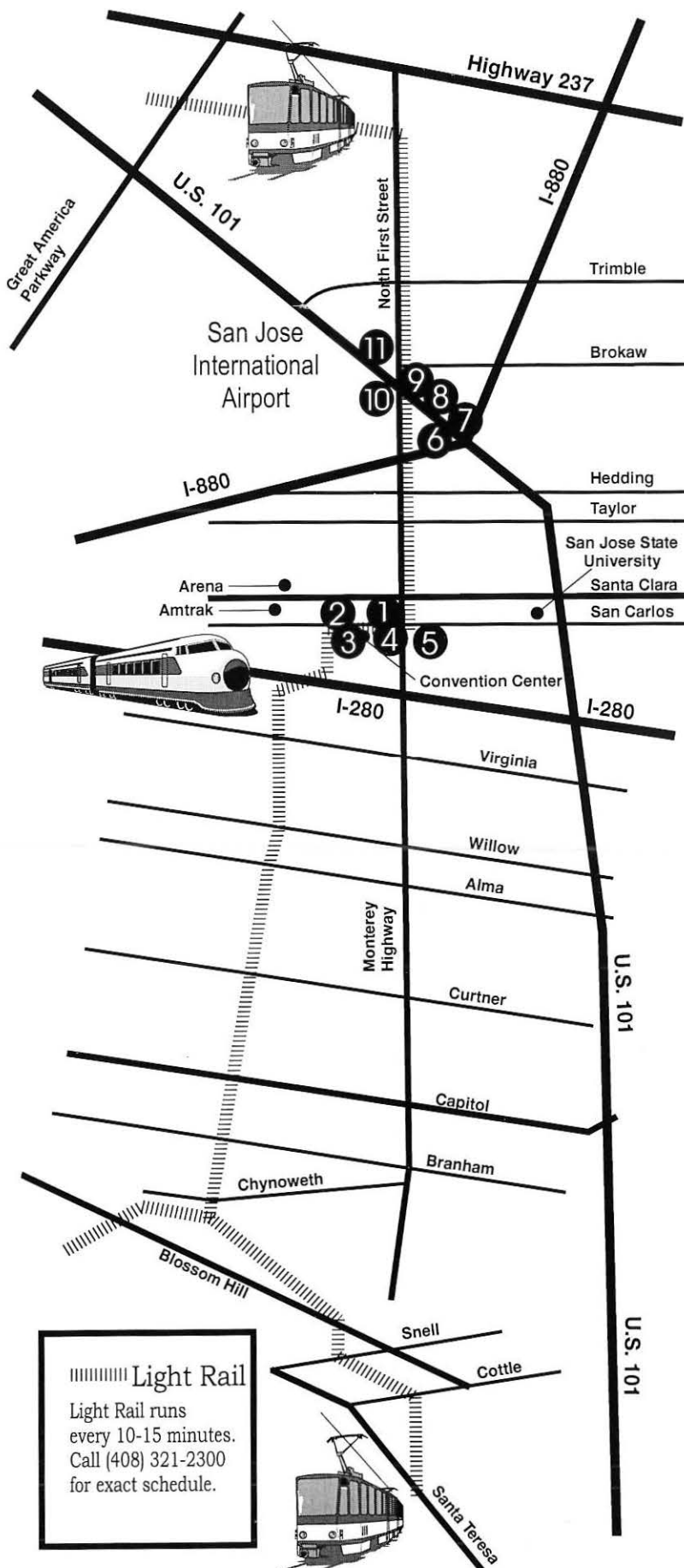

## Society for Informational Display

May 16 - 21, 1999

## Hotel Accommodations

- 1 Fairmont Hotel, Hdq. Hotel**
- 2 Crowne Plaza
- 3 Hilton & Towers
- 4 Hyatt Sainte Claire
- 5 Best Western
- 6 Wyndham Hotel
- 7 Airport Inn International
- 8 Radisson Hotel
- 9 Hyatt San Jose
- 10 Doubletree
- 11 Hanford

*San Jose*

Convention & Visitors Bureau

## sustaining members

Acer Display Technology  
 Ad-Vance Magnetics, Inc.  
 Arconium  
 Artesyn Solutions, Inc.  
 ATI Technologies  
 autronic - Melchers GmbH  
 BPS  
 Brewer Science, Inc.  
 Brimar Ltd.  
 Canon, Inc.  
 CELCO  
 Cherry Electrical Products  
 Chungwa Picture Tubes, Ltd.  
 Clinton Electronics Corp.  
 Colorado MicroDisplay, Inc.  
 Corning Japan K.K.  
 Crystaloid LCDs  
 Display Inspection Systems  
 Display Laboratories  
 DisplaySearch  
 Displaytech, Inc.  
 DNP Denmark  
 Dolch Computer Systems  
 Earth Computer Technologies  
 ELDEC Corp.  
 Electronic Designs, Inc.  
 Electro-Plasma, Inc.  
 Emco Electronics Ltd.  
 Endicott Research Group, Inc.  
 ERSO/ITRI  
 FED Corp.  
 F-P Electronics  
 Futaba Corp. R&D Center  
 General Vacuum, Inc.  
 Hewlett-Packard Co.  
 Hitachi, Ltd.  
 Hoya Corporation USA  
 IBM  
 Imaging & Sensing Technology  
 Incom, Inc.  
 Industrial Electronic Engineers, Inc.  
 Infinite Graphics, Inc.  
 Infodex, Inc.  
 Instrument Systems  
 Interface Products, Inc.  
 Interserv Corp.  
 Interstate Electronics Corp.  
 ISE Electronics Corp.  
 Kent Display Systems  
 Lexel Imaging Systems, Inc.  
 LinFinity Microelectronics, Inc.  
 Lite Array, Inc.  
 Micon Display Technology, Inc.  
 Microvision Corp.  
 Mitsubishi Electric Corp.  
 Mitsubishi Electronics America

Motorola FPD Division  
 NEC Corp.  
 Nippon Seiki Co., Ltd.  
 OIS Optical Imaging Systems, Inc.  
 OKI Electric Industry Co., Ltd.  
 Optical Coating Lab., Inc.  
 Optrex America, Inc.  
 Philips Flat Display Systems  
 Phosphor Technology Ltd.  
 Photon Dynamics  
 Photo Research  
 Pilkington Micronics Ltd.  
 Pix Electronics, Inc.  
 Planar America  
 Planar Standish, Inc.  
 Plasmaco, Inc.  
 Polar Vision, Inc.  
 Polytronix, Inc.  
 Q.C. Optics, Inc.  
 Quantum Data Inc.  
 RF Power Products  
 ROLIC Research Ltd.  
 Sarnoff Corp.  
 Schott Corp.  
 Semiconductor Systems, Inc.  
 Sharp Corp. - Japan  
 SI Diamond Technology, Inc.  
 Sony Corp. Research Center  
 Stanford Resources, Inc.  
 Supertex, Inc.  
 Symbol Technologies, Inc.  
 Syntronic Instruments, Inc.  
 Tamarack Scientific  
 TDK Corp.  
 TEAM Systems  
 Techneglas, Inc.  
 Teledyne Lighting & Display  
 Terapixel, Inc.  
 Thomas Electronics, Inc.  
 Three-Five Systems, Inc.  
 Toshiba America Electronic Corp.  
 Ultra Electronics Command &  
 Control Systems  
 ULVAC Technologies, Inc.  
 Unipac Optoelectronics Corp.  
 Universal Display Corp.  
 Ushio America, Inc.  
 Viratec Thin Films Inc.  
 Vishay-Dale Electronics, Inc.  
 Westaim Advanced Display  
 Technology  
 Westar Corp.  
 WinTron Technologies  
 XCITEK, Inc.  
 XMR, Inc.

## index to advertisers

BOC Coating Technology.....	15	Quantum Data .....	34,40
CyberTouch.....	31	Sencore.....	7
ELDIM.....	38	Society for Information Display .....	36
Ergotron .....	8	Team Systems .....	3,14
H. L. Funk Consulting.....	27	TEKRA .....	39
H. W. Grossbohlin .....	20	Three Five Systems .....	C3
LCD Lighting.....	41	Topcon .....	5
Microvision .....	9,37	Unigraf .....	27
NEC Technologies .....	21	Video Instruments.....	41
OCLI .....	6	ViewTEK .....	37
Optrex America.....	C2	Westar .....	8,C4
Polar Vision.....	20	WinTron.....	35

### Business and Editorial Offices

Palisades Institute for Research  
 Services, Inc.  
 411 Lafayette Street, 2nd Floor  
 New York, NY 10003  
 Jay Morreale, Managing Editor  
 212/460-8090 x212 Fax: 212/460-5460

### Sales Office

Palisades Institute for Research  
 Services, Inc.  
 411 Lafayette Street, 2nd Floor  
 New York, NY 10003  
 Michele Klein, Director of Sales  
 212/460-8090 x211 Fax: 212/460-5460

# Get Active

Three-Five Systems, Inc. is proud to introduce an off-the-shelf display solution - the LCaD™ 1/4 VGA display. LCaD™, Liquid Crystal Active Drive, is a passive matrix display which uses customized drive circuitry to scan multiple lines of the display simultaneously. The result is a display with a higher contrast ratio, wider viewing angle, and a lower power requirement than a display using conventional LCD drive techniques.

LCaD™ 1/4 VGA displays bring enhanced viewing capability usually reserved for active matrix displays at a fraction of the cost. The LCaD™ 1/4 VGA generates up to 16 shades of gray and is also easy to interface. With serial and parallel capability

for command/data and all LCD rastering self-contained within the LCaD™ display, developing exciting content of both text and graphics is just a few short programming steps away.

Is the information content of your design increasing? Is your instrumentation or appliance design in need of a facelift? Does your point of sale terminal need an enhanced capability to make a more user-friendly product? Then, get active with LCaD™ displays from Three-Five Systems. For more information or to learn more about how Three-Five's display solutions can revolutionize your products and your business, please contact us.



Display is actual size. LCD image has not been retouched.



**THREE-FIVE SYSTEMS, INC.™**

*We Display Excellence*

Three-Five Systems, Inc.  
Tempe • 602-389-8600 Fax: 602-389-8801

Three-Five Systems Ltd.  
Europe • 44-1793-549100 Fax: 44-1793-549135

Three-Five Systems, Inc.  
www.threefive.com email: Display@threefive.com

Circle no. 25

# When you want precision and flexibility...

## Westar's FPD Performance Measurement Systems

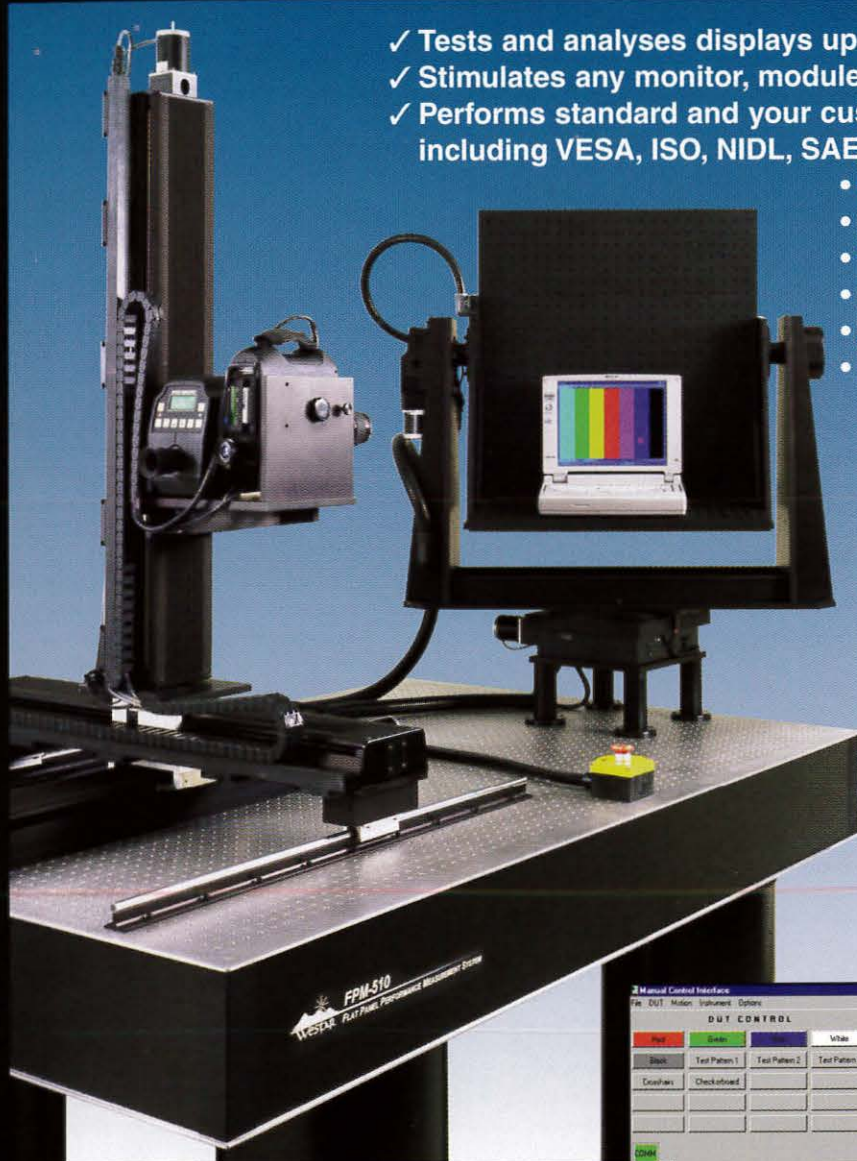

- ✓ Tests and analyses displays up to 54" automatically!
- ✓ Stimulates any monitor, module, or cell assembly
- ✓ Performs standard and your custom tests, including VESA, ISO, NIDL, SAE, and others!

- Luminance and Chromaticity
- Uniformity and Viewing Angle
- Shadowing (Crosstalk)
- Flicker and Response Time
- Power Consumption and L-P Ratio
- Ambient Contrast Ratio

✓ Uses all popular sensors!

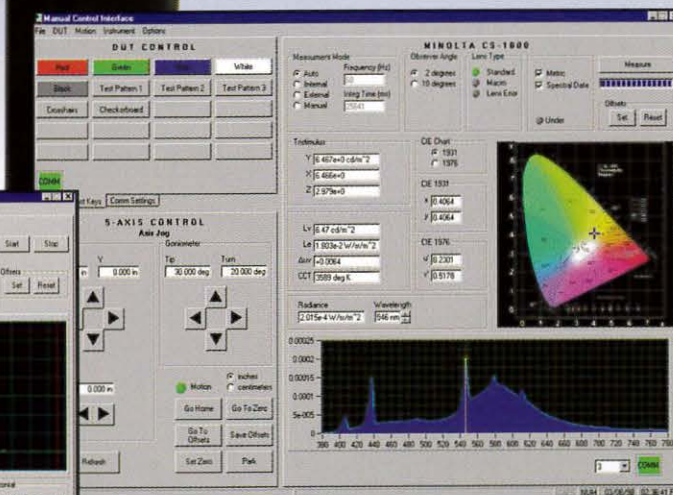
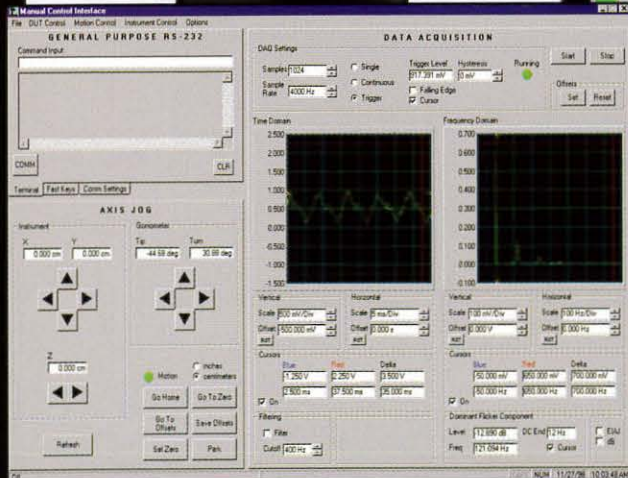

✓ Powerful ViewPoint™ software integrates all sensors, motion control, analysis, and reporting functions, including new e-mail and voice features! It also includes the widest variety of fully integrated display interfaces!

Call us for a demo CD and video or visit our website at <http://www.westar.com/id>.

Circle no. 26

USHQ: 1-314-298-8748 ext.286  
 Japan: KBK, Ltd. 03-3244-3795  
 Korea: Truco, Inc. 82-2-3487-1070-2

