

Official Monthly Publication of the Society for Information Display

INFORMATION SID DISPLAY

November 1997 – Vol. 13, No. 11

DISPLAY-MANUFACTURING ISSUE



New Neck-Down CRTs Open New Markets

LCD Backlighting
Neck-Down CRTs
New LCDs with Wider
Viewing Angles
In-Process Test Structures
and Strategies
Large PDP Manufacturing

we've got a secret.



LCiD™, a newly developed and patented liquid crystal technology offering sunlight readability and LED intensity at LCD prices.

For years we've become known as one of the world's premiere passive-matrix LCD companies. What the world doesn't know yet, is that we're also a leader in display technology research and development. Our U.S.-based R&D group is supported by the highest volume LCD glass manufacturing line in North America. From technology concept to process design, through initial prototypes and full production, the process is seamless. And that means quicker time to market for our customers. Whether a product requires a new display, or a new technology, we have the resources and the expertise. And that's no secret.



THREE-FIVE SYSTEMS, INC.

1600 N. Desert Drive
Tempe, Arizona 85281-1230
Phone 602-389-8600 Fax: 602-389-8989
Circle no. 1

Official Monthly Publication of the Society for Information Display

INFORMATION DISPLAY

NOVEMBER 1997
VOL. 13, NO. 11

COVER: A responsive yoke supplier has reduced manufacturing costs for the maker of this military thermal-imaging sight, which uses a neck-down CRT. As a result, the yoke manufacturer is helping the system maker to open civilian markets.

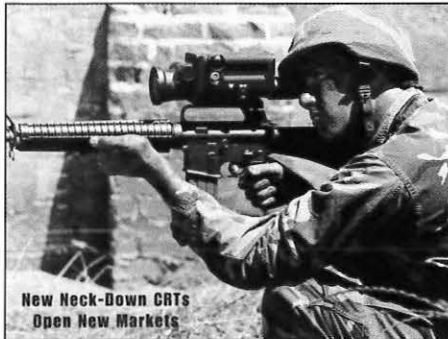

New Neck-Down CRTs
Open New Markets

Credit: Raytheon TI Systems

For more on what's coming in *Information Display*, and for other news on information-display technology, check the SID Web site on the World Wide Web: <http://www.sid.org>.

Next Month in *Information Display*

Display of the Year Awards Issue

- The perils of Plasmaco
- New LCD alignment techniques
- Making a projector lighter
- LC-modulated PL displays
- Display of the Year Awards

INFORMATION DISPLAY (ISSN 0362-0972) is published eleven times a year for the Society for Information Display by Palisades Institute for Research Services, Inc., 201 Varick Street, New York, NY 10014; David Slater, Chief Executive Officer; Leonard H. Klein, President; Laura Manganiello, Secretary/Treasurer. EDITORIAL AND BUSINESS OFFICES: Jay Morreale, Managing Editor, Palisades Institute for Research Services, Inc., 201 Varick Street, New York, NY 10014; telephone 212/620-3371. Send manuscripts to the attention of the Editor, ID. Director of Sales: Erika Targum, Palisades Institute for Research Services, Inc., 201 Varick Street, Suite 1006, New York, NY 10014; 212/620-3375. SID HEADQUARTERS, for correspondence on subscriptions and membership: Society for Information Display, 1526 Brookhollow Drive, Suite 82, Santa Ana, CA 92705-5421; telephone 714/545-1526; fax 714/545-1547. SUBSCRIPTIONS: *Information Display* is distributed without charge to those qualified and to SID members as a benefit of membership (annual dues \$55.00). Subscriptions to others: U.S. & Canada: \$36.00 one year, \$5.00 single copy; elsewhere: \$72.00 one year, \$6.50 single copy. PRINTED by Sheridan Printing Company, Alpha, NJ 08865. Third-class postage paid at Easton, PA. PERMISSIONS: Abstracting is permitted with credit to the source. Libraries are permitted to photocopy beyond the limits of the U.S. copyright law for private use of patrons, providing a fee of \$2.00 per article is paid to the Copyright Clearance Center, 21 Congress Street, Salem, MA 01970 (reference serial code 0362-0972/97/\$1.00 + \$0.00). Instructors are permitted to photocopy isolated articles for noncommercial classroom use without fee. This permission does not apply to any special reports or lists published in this magazine. For other copying, reprint or republication permission, write to Society for Information Display, 1526 Brookhollow Drive, Suite 82, Santa Ana, CA 92705-5421. Copyright © 1997 Society for Information Display. All rights reserved.

2 Editorial

Manufacturing for Design

Ken Werner

4 The Display Continuum

Let's Suppose ...

Aris Silzars

12 Noritake's New Equipment for Manufacturing Large PDPs

A new generation of manufacturing equipment has fabricated SXGA panels with 0.11-mm pixel pitch and rib widths of 0.03 mm.

*Masayuki Hiroshima, Susumu Sakamoto,
and Kazuo Kato*

16 Small Necks, Big Guns, and Snap-On Yokes

Neck-down CRTs combine the benefits of large electron guns and small tube necks, but customers wanted a yoke they could apply to these tubes themselves, rather than send tubes off-site.

Bradley A. Stump and Norman A. Lewis

20 Inspection and Test Techniques for FPD Manufacturing

Testing techniques are becoming highly accurate, and some are fast enough to be incorporated in high-volume production lines.

Tim Knuth and Jeff Hawthorne

26 Viewing-Angle Improvements for LCDs

Several techniques have dramatically increased the viewing angles of LCDs, but there's more to come – and soon.

Philip J. Bos and Ken Werner

32 Backlighting for Direct-View LCDs

There's a lot to think about when selecting an LCD backlight, but many solutions are available.

Ian Lewin

48 Sustaining Members

48 Index to Advertisers



Manufacturing for Design

I know. I have it backwards. It's design for manufacturing. Isn't it?

We have finally gotten to the point where it is considered very bad engineering manners for the design department to throw a product design over the partition to manufacturing and say, "Here it is. Make it." (The fact that it's bad manners and bad business doesn't mean that it isn't done, and done often. But

at least we've come far enough so that we are occasionally embarrassed by this kind of behavior.) At our best, though, we assemble integrated product design, manufacturing, and marketing teams who treat taking a concept to the consumer as a nearly seamless process.

This approach is much more sophisticated than "design for manufacturing." It acknowledges that there are multiple feedback loops in the process, and seeks to find competitive advantages in exploiting these loops - as some of the articles in this *ID* Manufacturing Issue point out.

In the wide-ranging "Viewing-Angle Improvements for LCDs," Phil Bos points out that using negative-birefringence films for improving the viewing angle of the black state is attractive not only for the striking performance enhancement they provide, but also because, as far as the manufacturer is concerned, this is only a simple film application.

In "Small Necks, Big Guns, and Snap-On Yokes," Bradley Stump and Norman Lewis relate how a customer's request led to the design of a molded, high-performance yoke for neck-down CRTs that permitted the customer to assemble the yoke and CRT in-house. Here, a component maker was able to use its design capability to modify its manufacturing practices and make its customer's manufacturing process more efficient.

We also tell you how testing techniques are becoming highly accurate, and how some are fast enough to be incorporated in high-volume production lines; how powerful VESA standards are now available to replace the now-obsolete VGA interface; and what you need to know to select a backlight for your display - or at least how to read the spec sheet.

So is this issue dedicated to manufacturing for design - which might mean manufacturing for the customer's design needs - or to design for manufacturing? Or is it dedicated to the need for mobilizing the entire product definition/design/manufacturing/marketing team to provide the customer with ever-increasing value?

In the spirit of participatory management, the decision is yours.

- Ken Werner

Information Display Magazine invites other opinions on this editorial or other subjects from members of the international display community. We welcome your comments and suggestions. You can reach me by e-mail at kwerner@netaxis.com, by fax at 203/855-9769, or by phone at 203/853-7069. The contents of upcoming issues of *ID* are available on the *ID* page at the SID Web site (<http://www.sid.org>).

Editor: Kenneth I. Werner
Managing Editor: Jay Morreale
Administrative Editor: Ralph Nadell
Assistant Editor: Dian Mecca
Contributing Editors: Aris Silzars, Bryan Norris, Chuck McLaughlin, Joe Hallett
Advertising Manager: Jay Morreale
Director of Sales: Erika Targum

Regional Associate Editors

Allan Kmetz (**Americas**)

*Lucent Technologies
 Murray Hill, New Jersey*

Shigeo Mikoshiba (**Asia**)

*University of Electro-Communications
 Tokyo, Japan*

Alan Mosley (**Europe**)

*Central Research Laboratories
 Hayes, Middlesex, U.K.*

Advisory Editors

Ken Compton

*Clinton Electronics Corp.
 Rockford, Illinois*

Carl Machover

*Machover Associates
 White Plains, New York*

Peter Pleshko

*PEMM Services
 Kingston, New York*

Alan Sobel

*Consultant
 Evanston, Illinois*

Webster E. Howard

*FED Corp.
 Hopewell Junction, New York*

The opinions expressed in editorials, columns, and feature articles do not necessarily reflect the opinions of the editor or publisher of *Information Display Magazine*, nor do they necessarily reflect the position of the Society for Information Display.

Powerful Video Generators. The Smart Choices.

STANDALONE

ASTRO VG-823

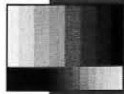

Dot Clock to 250 MHz
Horizontal Scan to
255KHz



Operated directly from
a PC or with "Remote"
Frontpanels



Compact/High
Performance

256 Levels at all
Frequencies



Standalone Units from **\$2950**

If you want a very flexible Video Generator, the Astro VG-823 is a high performance, lightweight and compact unit that offers the capability to test any high resolution display system up to 1600x1280 at high refresh rates.

With a RB-649 controller it's a bench top video generator. With the RB-614C Remote Box it's perfect for the manufacturing area and it can easily be programmed and operated from a PC via RS-232C—that's true multi functionality.

DIGITAL

ASTRO VG-826

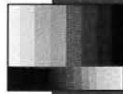

True "Digital" Video
Generator



Dot Clock to 60MHz /
120 MHz

Operated directly from
a PC or with "Remote"
Frontpanels



Very Compact &
Lightweight

8 Bits resolution/
pixel/ color



If you service, repair, evaluate or engineer modern Flat Panel Devices, the Astro VG-826 is the Digital Generator for you.

It's small and light enough to fit in your briefcase, yet has the performance to drive any single or multiplexed Flat Panel Device with a resolution of 24 bits per pixel up to a multiplexed frequency of 120MHz.

It can be programmed and operated from a PC or with the RB-646 "Remote" frontpanel or operated only with the RB-614C Controller.

PC-BASED

UNI VG-D250_{pc}

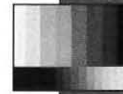

PC-based Performance

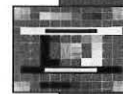

Dot Clock to 250MHz
Horizontal Scan to
250KHz



Fully Programmable
Patterns

Fully DDC Compatible
Accepts Bitmap-Files

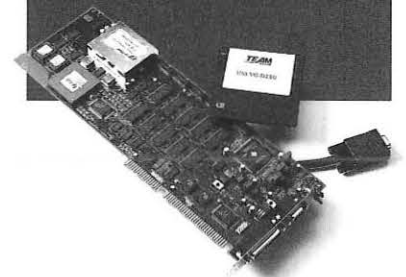

PC-Based Units from **\$2500**

This is the best PC-Based Video Generator if you work with Display Systems up to a 1600x1280 resolution. Its "DDC" capability is an increasingly important asset in service & manufacturing applications.

The UNI-VG-D250pc allows VESA-D.P.M.S. testing and the ability to import preset data files from other sources as "test patterns".

The user interface is DOS- and Windows 3.1 and very easy to operate.

Call **1-800-338-1981** Visit **www.team-systems.com**

TEAM
systems

TEAM Systems, Inc. 2934 Corvin Drive, Santa Clara, California 95051

"Test And Measurement Technology"



Let's Suppose ...

by Aris Silzars

Let's suppose that your bosses want to recruit you to manage the transfer of a new flat-panel-display technology from the laboratory-demonstration stage into manufacturable products. Your bosses, who have proudly and with considerable publicity acquired this new technology, expect these products to compete in a mainstream large-volume display application - let's say the laptop-computer market.

Wait! Wait! Come back! I know what you're thinking. I know that this already sounds like a "Mission Impossible" plot. So, OK. Just play along with me for at least a few minutes. Let's just see where this takes us.

"All right then, Dr. Phelps, your mission, should you choose to accept it, is to work with a small but highly skilled team to take a new display technology, the functioning of which has been fully demonstrated in *one* working laboratory model. This laboratory model met virtually all the performance specifications that customers will wish to have.

"The display model worked perfectly for exactly four minutes in the laboratory test set-up, at which time it emitted a mysterious flash, followed by a quick fade into non-functioning darkness - right before an eager potential-investor's eyes.

"The technology upon which this flat-panel display is based involves the well-known row and column addressing but has a new emission mechanism for direct-view laptop-computer and medium-size high-resolution full-video applications. Most of the materials are well understood and available, such as the glass plates for the back plane and the front viewing surface. There is, however, one set of difficult processing steps which can not be fully explained by the scientists who created the working laboratory model. These processing steps require some rather fine tolerances and careful handling of a unique deposition in a clean-room environment.

"But, Dr. Phelps, we know how capable you and your team are, and we have the highest confidence that this minor detail will not deter you from accomplishing your mission.

"Oh, and by the way, Dr. Phelps, there is just one unfortunate complicating factor. In order to raise the funds for your mission and for the manufacturing facilities, to which we have already committed, we had to promise the investors that you would have a manufacturable prototype to demonstrate at an investors' conference exactly 120 days from today. We are, of course, prepared to do whatever it takes to support your efforts in getting this mission accomplished. We have, in fact, set aside considerable funds as a further incentive to your team, for distribution upon the successful demonstration of the new display product.

"Finally, Dr. Phelps - by the way, may I call you James? - enclosed you will find a detailed description of the process that was used to fabricate the one demonstration model described earlier in this communication. The blank spaces you see are a few missing settings on the deposition equipment where the technicians neglected to write them down. But, since your team will be given full access to the equipment, we are sure that you won't have any difficulty finding

continued on page 42

SID Executive Committee

President: W. E. Howard
President Elect: A. C. Lowe
Regional VP, Americas: E. Stupp
Regional VP, Asia: H. Uchiike
Regional VP, Europe: E. Lueder
Treasurer: A. Silzars
Secretary: A. Kmetz
Past President: A. I. Lakatos

Directors

Bay Area: H. Sherman
Beijing: S. Ding
Belarus: A. Smirnov
Canada: V. Angelo
Delaware Valley: J. W. Parker III
France: F. Maurice
Greater Dayton: R. Holmes
Hong Kong: C. C. Chang
Japan: A. Iwamoto
Korea: C. Lee
Los Angeles: P. Baron
Metropolitan Detroit: R. Donofrio
Mid-Atlantic: D. Ketchum
Mid-Europe: R. Mauch
Minneapolis/St. Paul: V. Born
New England: W. Hamilton
Pacific Northwest: J. Rupp
Russia: M. Tomilin
San Diego: R. Ruff
Taipei: F. C. Luo
Texas: Z. Yaniv
U.K. & Ireland: R. Johnson
Ukraine: V. Nazarenko

Committee Chairs

Academic: C. J. Summers
Archives/Historian: R. C. Knepper
Bylaws: C. Infante
Chapter Formation: J.-N. Perbet
Convention: P. M. Heyman
Definitions & Standards: R. Miller
Honors & Awards: A. I. Lakatos
IDRC: F. J. Kahn
Intersociety: Z. Yaniv
Long-Range Planning: W. F. Goede
B. J. Lechner

Membership: J. W. Parker
Nominations: A. I. Lakatos
Office Liaison: D. Pinsky
Publications: A. Silzars
Journal Editor: A. Sobel
Information Display Editor: K. I. Werner
Communications: R. K. Ellis

Chapter Chairs

Bay Area: J. Larimer
Beijing: H. C. Hu
Belarus: E. Kaloshkin
Canada: A. Kitai
Delaware Valley: S. Kalatucka, Jr.
France: H. Brettel
Greater Dayton: J. Byrd
Hong Kong: H. S. Kwok
Japan: S. Mikoshiba
Korea: M. Oh
Los Angeles: M. Kesselman
Metropolitan Detroit: J. Erskine (Acting)
Mid-Atlantic: T. Nelson
Mid-Europe: M. E. Becker
Minneapolis/St. Paul: H. Holec
New England: P. Breen
Pacific Northwest: TBD
Russia: TBD
San Diego: R. Ditzik
Taipei: H.-P. D. Shieh
Texas: D. McFarland
U.K. & Ireland: B. Needham
Ukraine: V. Sorokin

Office Administration

Executive Administrator: Lauren Kinsey
Membership Coordinator: Nancy Stafford

Society for Information Display

1526 Brookhollow Drive, Suite 82
Santa Ana, CA 92705-5421
714/545-1526, fax -1547
e-mail: socforinfodisplay@mcimail.com
<http://www.sid.org>

Flat Panel Monitor **ARMS™**

Call: 1.800.888.8458

Ergonomically position your flat panel monitors, laptops and keyboards wherever you need them—with Ergotron's **Adjustable Rotating Mounting Solutions**

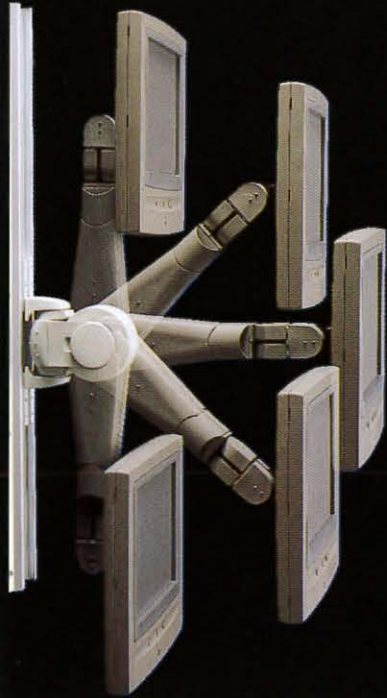

Mobile Solutions



Wall Mount Solutions

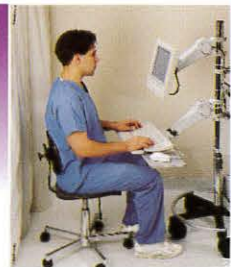

Custom Mount Solutions



Laptop Mounting Solutions



ERGOTRON®

1.800.888.8458 <http://www.ergotron.com>

Circle no. 3

We See FPD Controllers From Your Point Of View

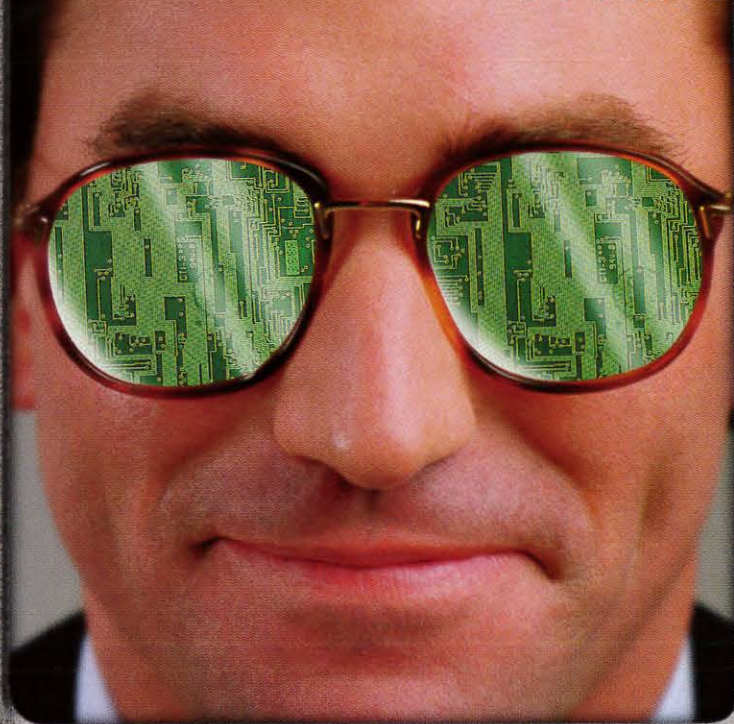

**Compact, Low Profile Solution
For VGA, SVGA Displays**

The LCD80xXCV

- 16.7M (24-bit) RGB Color Sampling
- Power Supply Sequencing
- On-Screen Display Menus Standard
- NTSC, PAL Composite & Y/C (S-Video) Support.
- Supports 4-, 6-, 8-bit Displays.

Additional High Performance Controllers Available.

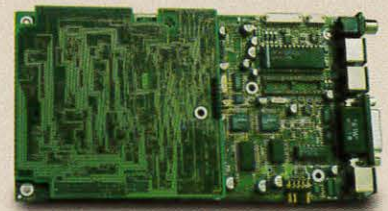

ViewTEK

Advanced Solutions for Display Technology

I-888-FLAT-PANEL

<http://www.view-tek.com>

Circle no. 4

MultiSync is a registered trademark and LCD2000, LCD400, XtraView, "Expect more. Experience more." and the NEC Technologies icon are trademarks of NEC Technologies, Inc. All other trademarks or registered trademarks are the property of their respective holders. ©1997 NEC Technologies, Inc.

BEHIND EVERY GREAT MONITOR THERE'S, UM, WELL NOTHING ACTUALLY.

MultiSync LCD Series	LCD2000™	LCD400™
Viewable Size	20.1"	14.1"
Max Resolution	1280 x 1024	1024 x 768
Weight	22.0 lbs.	11.5 lbs.
Dimensions (W, H, D)	19.7 x 19 x 8.7"	14.1 x 14.3 x 8.7"
Brightness	151 cd/m ²	180 cd/m ²
Viewing Angle	160° central XtraView technology	160°
LCD Type	Active Matrix	

There is, however, plenty inside. For starters, both of our space-saving MultiSync® LCD monitors feature XtraView™ technology, which opens up the viewing angle to a panoramic 160°. The screen itself is flat, and presents a brighter, flicker-free image. While they consume less space than regular monitors, our LCDs also weigh in about 70% lighter. Which makes wall mounting the LCD2000 a breeze. Plus, they both boast

reduced emissions and energy consumption. So really, what's behind our MultiSync LCD monitors is, as always, a continued commitment to creating

outstanding products. To learn more, call 1-800-NEC-INFO. Or, if you prefer, please visit us at www.nec.com. Expect more. Experience more.



A big thumbs up to our R&D department for creating the MultiSync LCD2000, the first ever 20.1" viewable LCD monitor to be made for commercial use.

NEC
NEC Technologies

Both models are compatible with PC, Mac, Workstation or any VESA compliant analog RGB signal, no special card required.

Circle no. 5

GET UNPLUGGED FROM OLD DISPLAY IDEAS

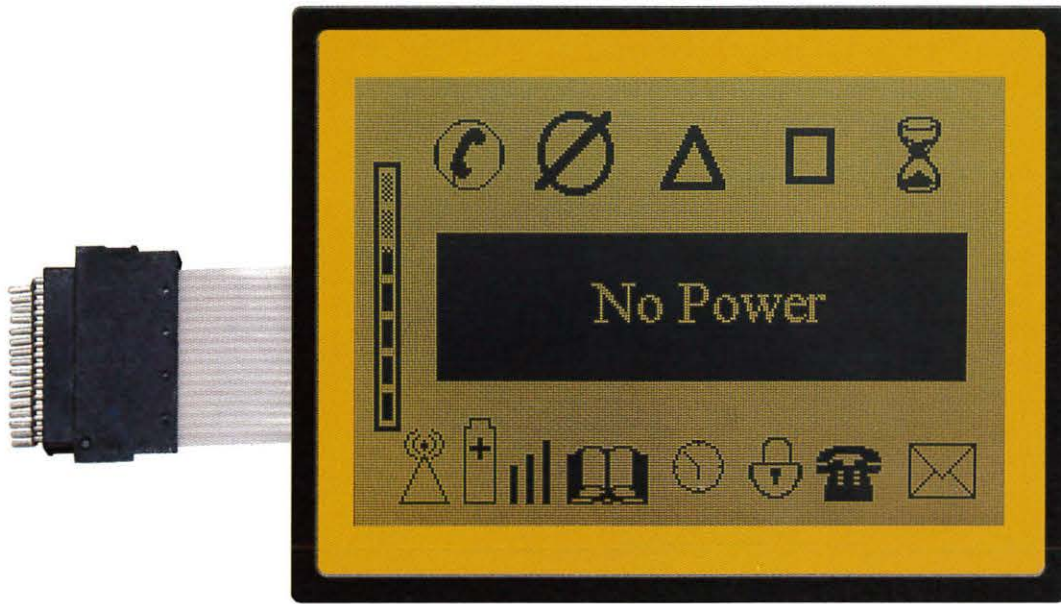

KENT ChLCD™ No Power Displays

Ready to get unplugged from the energy-robbing LCD displays you're now using? KENT Displays' ChLCD (Cholesteric Liquid Crystal Display) technology offers a solution for your electronic products.

BREAK THE BATTERY-DRAIN BARRIER

Since ChLCD reflective and transparent textures are both stable states, an image can be displayed indefinitely without consuming battery energy – for seconds, hours, weeks, months or even years.

EASIEST TO READ REFLECTIVE TECHNOLOGY

Compared to conventional LCD technologies, ChLCD displays offer better reflectiveness, 360 degree viewing cone and exceptional daylight contrast, even in direct sunlight, all without backlighting.

STANDARD OR CUSTOM DISPLAYS AVAILABLE

Standard ChLCD displays and modules are available in 1/8 and 1/2 VGA sizes in colors to meet your needs. Have a special application? Kent Displays offers ChLCD displays and modules custom designed to your requirements.

ASK FOR THE FACTS

To learn more about this technology that enables you to do more, ask for this information package today. — — — — —

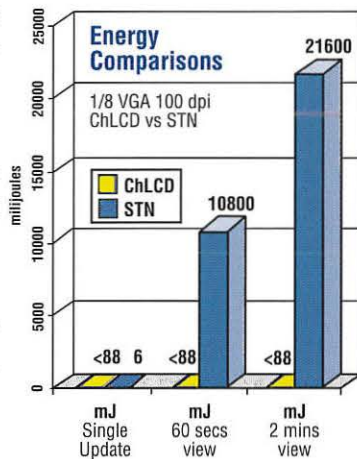

Unlike STN displays which use power to continuously refresh images, ChLCDs do not require refreshing to keep energy usage to a minimum.



KENT DISPLAYS
INCORPORATED
A MANNING VENTURES BUSINESS UNIT

Kent Displays, Inc. • 343 Portage Boulevard • Kent, OH 44240 • Phone: 330.673.8784 • Fax: 330.673.4408 • E-mail: 73360.2157@compuserve.com

Products and technologies of Kent Displays, Inc. are protected by the following patents: Unites States: 5,463,863; 5,437,811; 5,384,067; 5,251,048. People's Republic of China; 92103952.2. Israel; 101,766. Taiwan; 801-405631. PCT (EP, Canada, Korea, Japan and Norway); 92/03504; 9209367. Other Patents Pending.

Circle no. 6

**IMPORTANT NEWS FOR
FLAT PANEL PRODUCERS.
FROM THE WORLD LEADER
IN ION IMPLANTATION.**

Since 1978, Eaton has been the number one producer of ion implanters for semiconductor production. Now, we have applied this expertise in implantation to the specific needs of the flat panel industry. We are proud to introduce the revolutionary Eaton ORion NV6072, a simple and cost-effective implant solution designed to improve process yields while reducing the cost of ownership. You owe it to yourself, your customers, and your bottom line to find out more.

EATON

Semiconductor Equipment Operations
Flat Panel Equipment

Eaton Corporation
Semiconductor Equipment Operations
Flat Panel Equipment
108 Cherry Hill Drive
Beverly, MA 01915
Tel: 508-524-9233
Fax: 508-524-9224

Circle no. 7

Japan
SEN
Sumitomo Eaton Nova Corporation
Mita 43 Mori Bldg., 13-16, Mita 3-Chome
Minato-Ku, Tokyo, 108, Japan
Tel: (03) 3452-9021
Fax: (03) 3452-9025

A Great VIEW From Any Angle.

Anyway you look at them, Mitsubishi's ANGLEVIEW™ TFT-LCDs give you a great view. And with a 4.3µm cell gap design, they give you a high contrast ratio without off-axis image reversal, plus rich, saturated color for breathtaking front-of-screen viewing.

As a leader in display technology for over 20 years, Mitsubishi continues to develop advanced color TFT-LCD technologies:

- Wide Viewing Angle (120°+)
- High Luminance (200+ Nits)
- EMI Compliant (CISPR B)
- Low Power Consumption (<2.0 Watts)

The Mitsubishi TFT-LCD product line includes displays designed specifically for key markets, including: portable computing, flat panel monitor,

**ANGLE
VIEW**

workstation, instrumentation and industrial control. Interface support includes CMOS/TTL, FPD Link™ and Flat Link™

(LVDS), and Panellink™.

Worldwide Service and Support

For a great competitive advantage, Mitsubishi provides service and support on three continents: Europe, North America and Asia. Enjoy the view. Call 408-774-3189, or get a great view from our web site at www.angleview.com.

ANGLEVIEW is a trademark of Mitsubishi Electronics America, Inc. All other trademarks are the property of their respective owners.

Circle no. 8



 **MITSUBISHI**
ELECTRONIC DEVICE GROUP

Noritake's New Equipment for Manufacturing Large PDPs

A new generation of manufacturing equipment has fabricated SXGA panels with 0.11-mm pixel pitch and rib widths of 0.03 mm.

by Masayuki Hiroshima, Susumu Sakamoto, and Kazuo Kato

THE MASS PRODUCTION of large high-resolution ac-plasma display panels (ACPDPs) requires dimensional accuracy and the ability to produce small features precisely at high speed. The panel structure at the current stage of ACPDP development is much the same for most manufacturers, but each manufacturer has its own fabrication methods. Noritake has years of experience fabricating PDP panels with screen-printed barrier ribs.

In the effort to develop fabrication methods for the next generation of panels, some manufacturers have been exploring sand-blasting and other techniques for forming barrier ribs. They have done so in the belief that screen printing could not economically produce ribs for the finer pixel pitches needed for SVGA, XGA, and SXGA displays. But Noritake retained its confidence in the capabilities of screen printing and has been concentrating on developing screen-printing methods to lower costs and decrease feature sizes.

Masayuki Hiroshima, Susumu Sakamoto, and Kazuo Kato are with the Kyushu Noritake Co., Ltd., 2160 Minami, Yasu-cho, Asakura-pref., Fukuoka, Japan 838-02. Susumu Sakamoto may be reached by phone at +81-946-42-4171, by fax at +81-946-42-1275, or by e-mail at XLH02765@niftyserve.or.jp. This article was adapted from the authors' paper, "New Equipment for Manufacturing Large Sized PDPs," delivered at the Display Manufacturing Technology Conference at Display Works 97, San Jose, California, January 29-30, 1997.

In the mid-90s, typical commercially available equipment did not possess the characteristics necessary for factory production. Therefore, Noritake independently developed PDP-fabrication equipment which was successfully used to produce prototypes for 42-in. VGA plates in 1995. Subsequently, equipment suitable for high-volume mass production was developed and improved, and mass production began in 1996. At Display Works

in January 1997, Noritake publicly introduced this equipment, as well as 21-in. SXGA prototypes fabricated with a fine-feature screen-printing process.

Precise Patterning

For large HDTVs, it is imperative to develop processes that can achieve precise patterning. Proper process building is necessary and over-specification must be avoided. Noritake's



Fig. 1: Inclined PDP screen printers are more precise and occupy less floor space than traditional horizontal printers. This printer can accommodate screen mask frames up to 1800 x 1500 mm.

Noritake

Table 1: Screen-Printer Specifications

	Typical Printer	1993 Noritake Printer	1996 Noritake Printer (Patented)
Structure	Horizontal	Horizontal	Inclined
Panel size	40-in. class	55-in. class	42-in. class
Screen mask frame (mm)	1500 × 1500 (max)	1800 × 2300 (max)	1500 × 1800 (max)
Machine size (mm)	3650 × 2400 × 1650 (H)	4750 × 2800 × 1450 (H)	3135 × 1500 × 2050 (H)
Weight (kg)	7500	4000	2000

objective is to develop appropriate technology using a screen-printing process and soda-lime glass substrates for better cost/performance.

Ceramic-Roller Hearth Furnace

Although adoption of a photolithographic patterning method provided dimensional accuracy and fine precision, problems arose at the next stage in the panel-fabrication process, where firing produced substrate warpage, shrinkage, and transformation. Using glass with a higher strain point is one way of avoiding deformation, but for 55-in.-class or high-resolution panels targeted at HDTVs it is still imperative to have a process that maintains temperature uniformity and dimensional stability. Noritake has developed a new furnace with both continuous and intermittent conveying systems.

The shrinkage of glass substrates during the annealing process causes dimensional unevenness. When uneven shrinkage occurs in the glass plate, it is almost impossible to adjust it in the process. Conventional continuous furnaces do not provide for adequate measurement to minimize such unevenness. The only way to minimize the problem is to extend the length of the furnace.

Noritake's new furnace design includes a separate chamber in the annealing zone and an intermittent conveyor which can cool an entire plate or any part of a plate. As a result, the evenness in the shrinking rate within a plate can be controlled, and dimensional revision becomes practical. A level of dimensional stability can be obtained even with low-cost soda-lime glass.

The binder used in the glass paste that is screen printed onto the panel to make the barrier ribs must be burnt off during the firing processes. Effective binder burn-off is as important as the temperature for securing

panel quality, and good binder burn-off becomes more difficult as one attempts to increase furnace productivity. The difficulty increases if panels are printed or coated with too much paste, a transparent dielectric layer is fired, or many plates are treated. The new furnace supplies an exhaust-gas system and a continuous conveyor in its heat-up zone to maintain a suitable burn-off condition. If a specific thick-film firing does not require a critical burn-off condition, the furnace can be fired at a multistage setting.

The furnace capacity is 250-300 sheets per 24 hours. (The length of the furnace is 19.5 m and its maximum temperature is 590°C. The total time to process a panel through the furnace is 80 min).

Dust in furnaces reduces the manufacturing yield of large panels. In furnaces with a metal muffle and mesh-belt drive, abrasive metal powder and oxidized scale are the chief causes of panel defects. As anti-dust measures, Noritake has adopted a ceramic-roller hearth structure and a muffle made of heat-resistant glass. Rollers made of ceramic pipes, similar to those used in Noritake's chinaware firing, have been achieving good results.

An alternative roller-fabrication approach is far less satisfactory. Ceramic conveyor tubes are placed on stainless pipes at intervals. In this design, heat diffuses through the metal pipes, which compromises the desired heat-insulation effect. In addition, the back sides of the setters (made of heat-resistant glass) become worn because they are not as hard as the ceramic pipes. The distribution system wears speedily and unevenly with this approach.

Inclining the Screen Printer

Typical screen printers now on the market for fabricating large PDPs process glass panels horizontally. As a result, these printers are too big and complicated for large-scale manufacturing. Noritake has developed an inclined printer which is being used successfully to make 40-42-in.-panel prototypes (Fig. 1). The specifications of two horizontal printers and the new inclined printer are compared in Table 1.

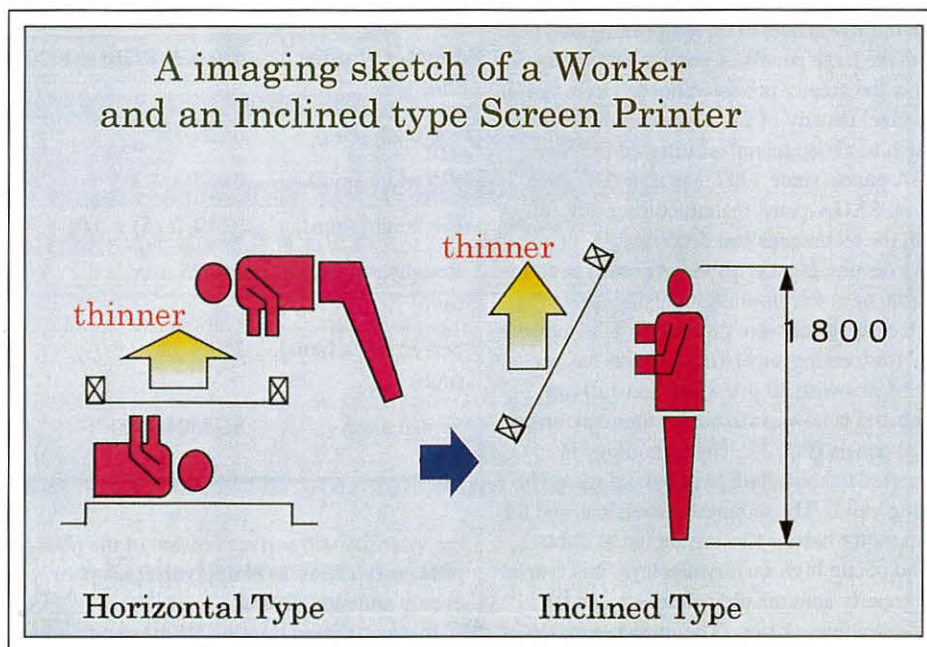

Fig. 2: The inclined printer design offers easier and safer operator access.

PDP manufacturing

One factor that limits uniform patterning in screen printing is that the weight of the screen mesh and paste balances some of the restorative force arising from screen tension. An inclined printer eases this problem considerably. In the case of a screen inclined at an angle of 60°, the component of the weight that is normal to the screen is half the total weight, so there is more restorative force available for good screen lift-up and good stability for printing large patterns.

Now that manufacturers are preparing for the high-volume manufacture of large panels, difficulties in the use of horizontal printers are becoming apparent. Workers have to reach over awkwardly long distances to perform various operations on the screen frame, including the application of chemical solvent. An inclined printer dramatically eases these problems. Because printing plates are located closer to a worker, the quality and condition can be visually confirmed directly at both sides of a screen mask (Fig. 2).

The inclined design also reduces the necessary floor space by half, so factory space can be utilized more efficiently. The designers also made a particular effort to design a lighter-weight printer to reduce floor loading, producing a printer of about one-fourth the weight of previous printers for 40-in.-class panels.

21-in. Screen-Printed SXGA Panels

The improvements in screen printing that help us make large panels of good quality also allow the greater precision needed to increase the pixel density of 21-in. panels. Noritake, which has been manufacturing 20-in.-class VGA panels since 1992, has now developed 21-in. SXGA-panel manufacturing technology with the techniques just described.

In developing a process for prototype fabrication, new screen-mask emulsions and dielectric pastes were produced. This technology for forming super-fine patterns has produced ribs with 30 µm width and 110 µm pitch and is now available for manufacturing large panels (Fig. 3). The technology is expected to contribute to improved manufacturing yield. The required dimensions and tolerances for barrier ribs are shown in Table 2.

To obtain high-quality displays, it is crucial to properly coat the phosphor between the fine-pitch barrier ribs. The implementation of a phosphor-printing technology that controls

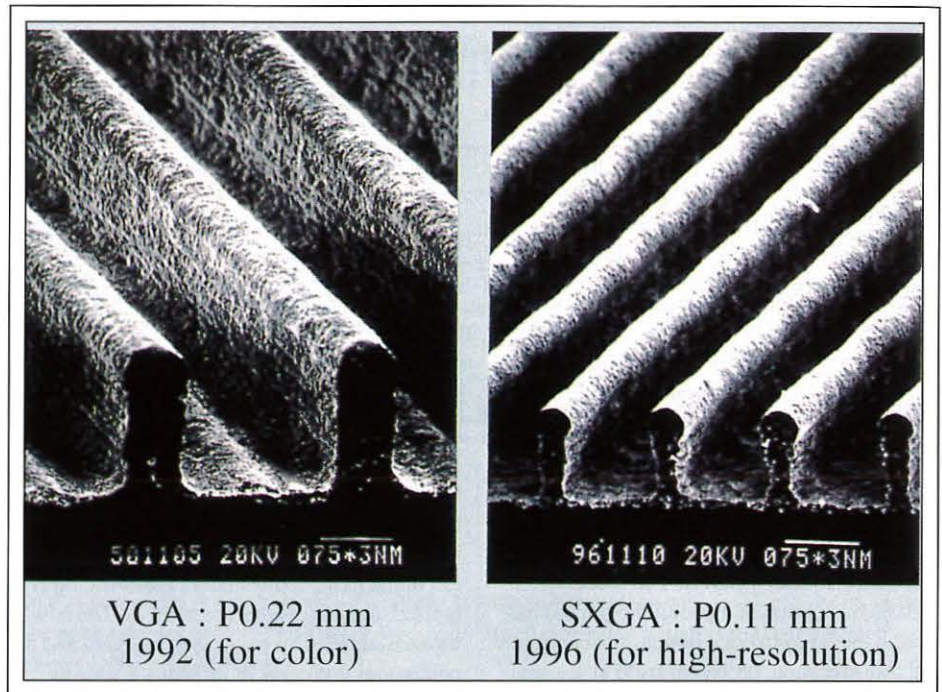

Fig. 3: Scanning-electron-microscope photographs of the barrier ribs (VGA and SXGA) with the same size scale.

Noritake

Table 2: Required Dimensions and Tolerances for Barrier Ribs

	Typical	High Resolution	Large Size
Display	21-in. VGA	21-in. SXGA	42 in. wide (16:9)
Number of stripe ribs	640 × 3 (RGB) = 1920	1280 × 3 (RGB) = 3840	852 × 3 (RGB) = 2556
Rib pitch (mm)	0.22	0.11	0.36
Rib width (mm)	0.055 ± 0.005	0.030 ± 0.003	0.1 ± 0.01
Rib height (mm)	(0.10–0.15) ± 0.01	(0.10–0.15) ± 0.005	(0.10–0.15) ± 0.01
Roughness, rib top (mm)	0.0025 max	0.0025 max	0.005 max
Screen mask frame (mm)	750 × 750	750 × 750	1500 × 1800
Screen mesh	SUS304 #400	SUS304 #400 (calendered)	SUS304 #325

the viscosity and surface tension of the phosphor paste allows us to apply the phosphor evenly and repetitively.

In short, screen printing has been refined to the point that it is now a practical high-vol-

ume manufacturing process for both 40-in.-class color PDPs and workstation/HDTV-class PDPs requiring cell pitches as low as 0.11 mm. Prototype SXGA 21-in. PDPs have already been fabricated. ■

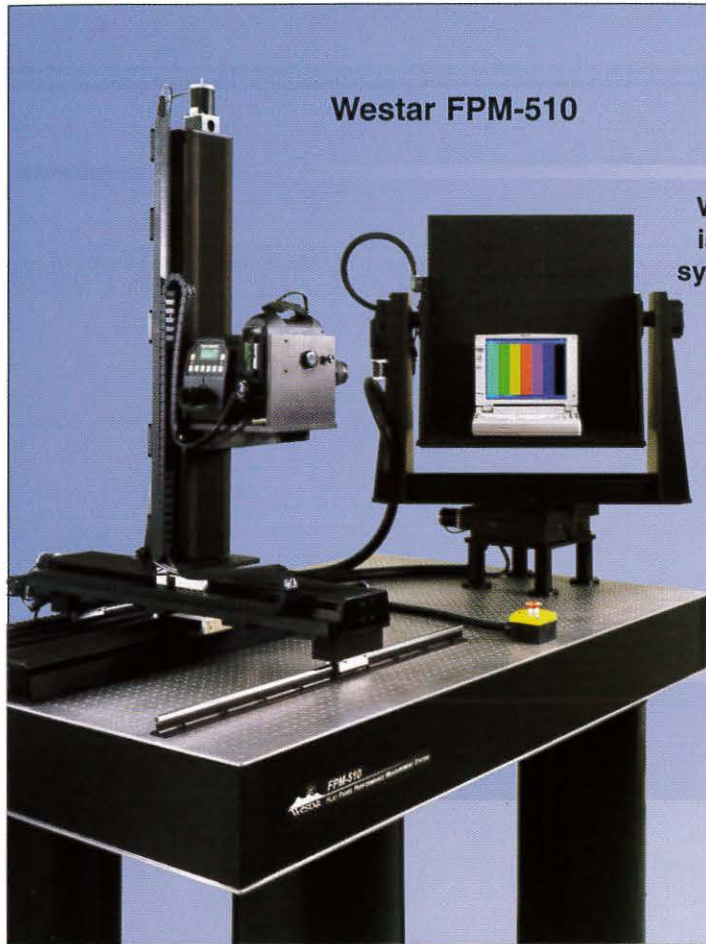

Westar FPM-510

FPD Monitor / Module Test System

Westar's FPM Performance Measurement System is the only integrated stimulus and measurement system that works with several leading instruments.

- Turnkey 5-axis motion-controlled platform maintains spot size for extreme accuracy
- ViewPoint™ software automates VESA FPD compliance testing, including flicker and response time
- Stimulus solutions for monitors, modules, AMLCD cells, FED, Plasma and CRTs
- Tests display sizes up to 42" x 24"
- Options include thermal chambers, multiple sensors, shock mounts, and production fixtures

To learn more about the FPM system and other Westar display test and interface products, contact us at (314) 298-8748, ext. 286 or visit us at www.westar.com/esg



Westar Corporation

Circle no. 9



Klein VPG Video Pattern Generator 250 MHz and Fully Featured

250MHz
4 Line LCD
600 Timings
48 Patterns
User Modifiable Patterns
Stand Alone or PC Controlled
Fully Field Upgradeable

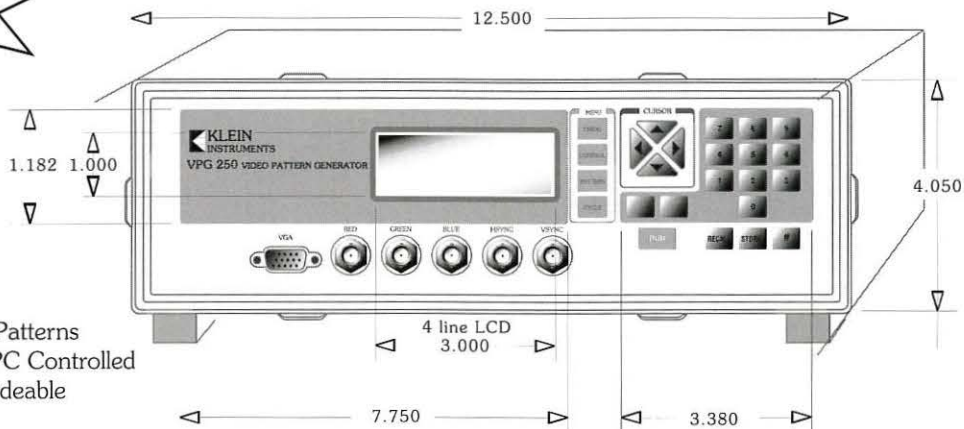

If the outside impresses you...wait 'til you see what the inside will do.



Klein Instruments, Inc.
Portland, Oregon
Ph: (503) 245-1012 Fax: (503) 245-8166
Email: sales@Kleininc.com

Klein Instruments has been making monitor test equipment since 1983.

Circle no. 10

Small Necks, Big Guns, and Snap-On Yokes

Neck-down CRTs combine the benefits of large electron guns and small tube necks, but customers wanted a yoke they could apply to these tubes themselves, rather than send tubes off-site.

by Bradley A. Stump and Norman A. Lewis

IN JULY of 1996, TWA Flight 800 crashed off the coast of Long Island, New York. Authorities there turned to the latest in thermal-imaging technology. This search-and-rescue equipment utilized not a flat-panel display but a neck-down CRT.

As the 100th anniversary of the CRT is celebrated, developments in FEDs, AMLCDs, and other flat-panel technologies continue to drive the CRT industry to new heights of development. One of the drivers for CRT-product enhancement has been the need for physically smaller displays with better spot growth and lower power requirements. In the early 1980s, Tektronix developed an electron tube that did just that: the neck-down tube (Fig. 1).

The neck-down tube's primary advantage is its larger electron-gun structure. The larger gun provides better electron-beam diameters, resulting in a smaller center pixel. Of course, one can always put a large gun in a tube with a wide neck, but the smaller neck diameter of the neck-down CRT permits the yoke to be closer to the beam for improved sensitivity. (Most CRT manufacturers agree that there is a distinct sensitivity advantage with a neck-down CRT.)

Sensitivity is the amount of current necessary to deflect the electron beam by a given angle for a given amount of high voltage. With increased sensitivity, less current is

required to deflect the electron beam, resulting in a system that requires less power to operate and runs at a lower temperature. This sensitivity advantage is inversely proportional to the radius of the yoke winding in the

deflection area; thus, a larger neck size requires more deflection power. This relationship creates a conflict between spot size and deflection power, which leads to problems in achieving higher resolution.

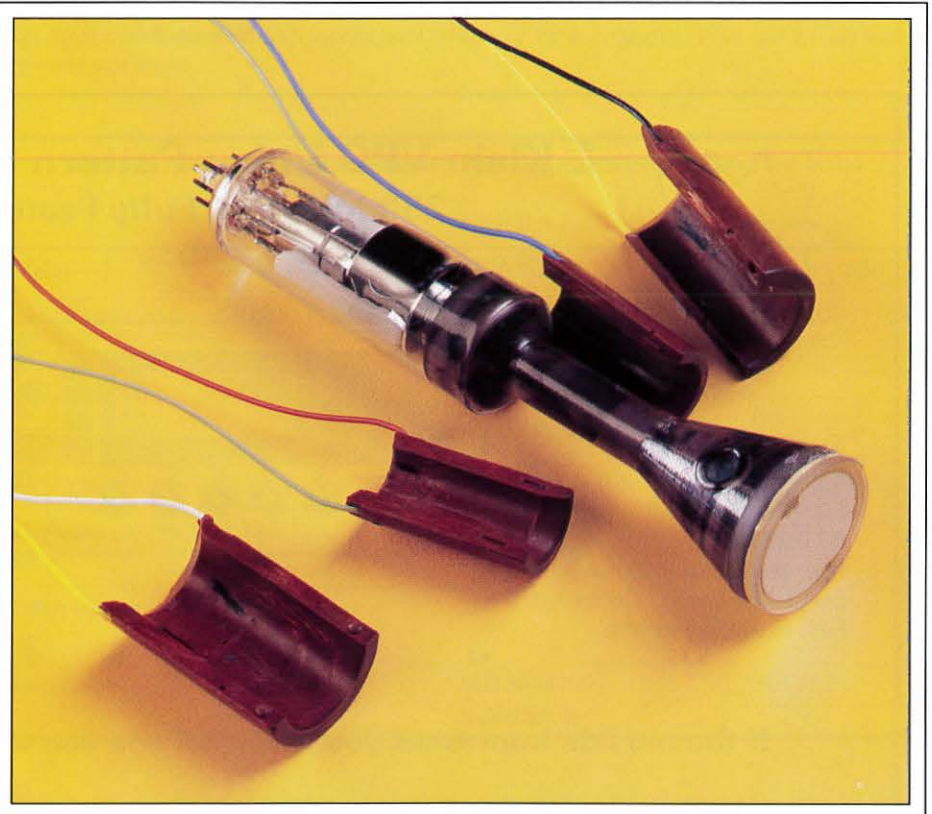

WinTron, Inc.

Fig. 1: A neck-down CRT allows a large-diameter electron gun to be combined with a small-diameter tube neck. The molded components of WinTron's snap-on deflection yoke are shown next to the tube.

Bradley A. Stump is an industrial engineer at WinTron, Inc., 250 Runville Rd., Bellefonte, PA 16823; telephone 814/355-1521, fax 814/355-1524, e-mail: wintron@vicon.net.
Norman A. Lewis is a deflection-yoke engineer at WinTron.



Raytheon TI Systems

Fig. 2: Raytheon TI Systems uses neck-down CRTs in their TISIGHT, which is used on the M-16 automatic rifle shown here and the M-60 machine gun.

There are now three neck-down-CRT manufacturers: Imaging and Sensing Technology (IST), Horseheads, New York; Thomas Electronics, Wayne, New Jersey; and Brimar Limited, Manchester, U.K. IST and Thomas will not sell the tube alone, only as a yoke/tube match. Neither IST nor Thomas were able to compare the price of their neck-down tubes to equivalent conventional tubes for this article because the neck-down tubes are for higher-performance applications. However, the tube manufacturers can determine when a neck-down tube will benefit a customer's application. The price varies, depending on a customer's exact needs.

Many of the markets utilizing neck-down CRTs require portability for applications such as helmet-mounted displays, and battery life is critical in such applications. Not only will using a neck-down tube extend battery life but the entire system will operate more efficiently.

Raytheon TI Systems is currently one of the leading users of this technology, incorporating neck-down tubes in the TISIGHT thermal-imaging sights used on the M-16 automatic

rifle and M-60 machine gun (Fig. 2). The TISIGHT is a thermal-imaging sight for surveillance and weapon sighting at night, or when the target is concealed by foliage or not clearly separated from a cluttered background. The image is conveyed to the internal monitor built around the neck-down tube via a standard RS-170 interface (Fig. 3).

Raytheon TI envisions a variety of emerging new markets for this technology, including marine, surveillance, federal agencies (non-DoD), security, driving aids (military and commercial), industrial/building monitors, search and rescue, automotive, public sector (police/fire), and government/military. As displays find their place in these markets, the demand for smaller, more efficient monitors with higher resolution is likely to grow.

A New Yoke for In-House Assembly

In the past, using a neck-down tube required the customer to send the CRT to a yoke vendor for assembly. The customer had to incur additional shipping and handling costs and then work with the yoke vendor's schedule in order to obtain a complete yoke/tube assembly. Some yoke customers have been hesitant to send their CRTs across the country or across an ocean and risk breakage.



Raytheon TI Systems

Fig. 3: The infrared image from TISIGHT's sensor is conveyed through a standard RS-170 interface to an internal monitor built around a neck-down CRT.

CRT components

At the request of one of these customers, WinTron developed an alternative approach that allows a complete deflection yoke to be shipped to the CRT customer for easy assembly on a neck-down tube – an approach that could eliminate additional shipping costs and scheduling headaches. Such a yoke could decrease the customer's cycle time and improve production flow. In the last quarter of 1996, WinTron set out to develop a process for encapsulating the deflection yoke's magnetics to help yoke customers achieve these goals.

Every yoke designed for a neck-down tube is a custom application, and the yoke's specifications are driven by the tube manufacturers. The first encapsulated yokes were designed to meet the same specifications as the non-encapsulated neck-down yokes being produced at that time.

Developing the New Yoke

WinTron's development process began with conversations concerning the production of a prototype unit. Initial discussions focused mainly on the construction of the mold. While this task seemed simple at first glance, several factors unique to this yoke design began to surface.

First, the amount of overmolding needed to be decided. Excess material would make for a sturdier unit but would increase physical size and decrease sensitivity. If the amount of overmolding were reduced to a bare minimum, the molding process itself would become more difficult because there would be only limited free space in the mold into which material could enter while air was exiting. After several iterations of CAD drawings and calculations, the final mold design was approved.

The mold was designed to hold the coils so that most of the excess molding material migrates to the outer diameter. This feature allows the coils to lie as close as possible to the neck of the tube, thus maximizing the unit's sensitivity. Precisely placed channels and a fill basin were added to properly direct the molding material. Locating features were incorporated into the mold to make the alignment of the paired coils as simple as possible. With the physical mold in hand, the designers' focus shifted to the molding process.

Designing a Manufacturing Process

The first step in defining the production process for the yoke was the selection of the

molding material. Thermoplastics were eliminated from consideration for two main reasons. First, the limited fill area that was available required a material with very low viscosity. In order to lower the viscosity of certain thermoplastics, the working temperature had to be rather high compared to the tolerance temperature of the insulation on the magnet wire used for the coils, so we were concerned about damage to the coils. A suitable thermoplastic may exist, but both time and cost constraints pointed to the use of a two-part-epoxy encapsulating system. This material did not affect the rise in coil temperature by more than 4°C during the testing process.

The next hurdle was selecting the proper positions for the lead exits. The tradeoff between desired location and molding space was resolved through the production of various sample coils. In their current location, the lead exits do present a critical molding problem: holes at the bottom of the mold. These openings were made as small as possible, and further process modifications allowed the openings to be completely sealed. This was important because preventing material leakage was essential to the formation of completely filled, void-free units.

The actual molding process involves variations of mold temperature and atmospheric pressure. In injection molding, the material is usually injected at an elevated temperature under some amount of increased pressure.

For the yoke coils, the system temperature was increased as the molding material was introduced into the mold. The entire assembly was then placed under vacuum to pull the air out of the mold and allow the material to fill even the tiniest mold features. The assembly was then heated until the epoxy cured.

Once the material had hardened and the mold had cooled sufficiently, the formed units were extracted. Careful mold design and proper pre-treating of the mold enabled the units to be removed with little difficulty and no damage. As with most molding processes, it was necessary to trim flashing and polish the final unit. The engineers were extremely gratified when the molded horizontal and vertical units assembled quickly onto a neck-down tube, requiring not the expert touch of a seasoned worker but just the simple ability to match the locating features.

The yoke is assembled on the CRT in a fourfold process:

- Assembly of the horizontal coil set.
- Assembly of the vertical coil set.
- Performance of a crosstalk (orthogonality) check to ensure that the vertical set of coils are as close as possible to 90° with respect to the horizontal set so that there is no signal coupling between the two coils.
- Placement of a ferrite sleeve core or a piece of Mumetal around the coils.

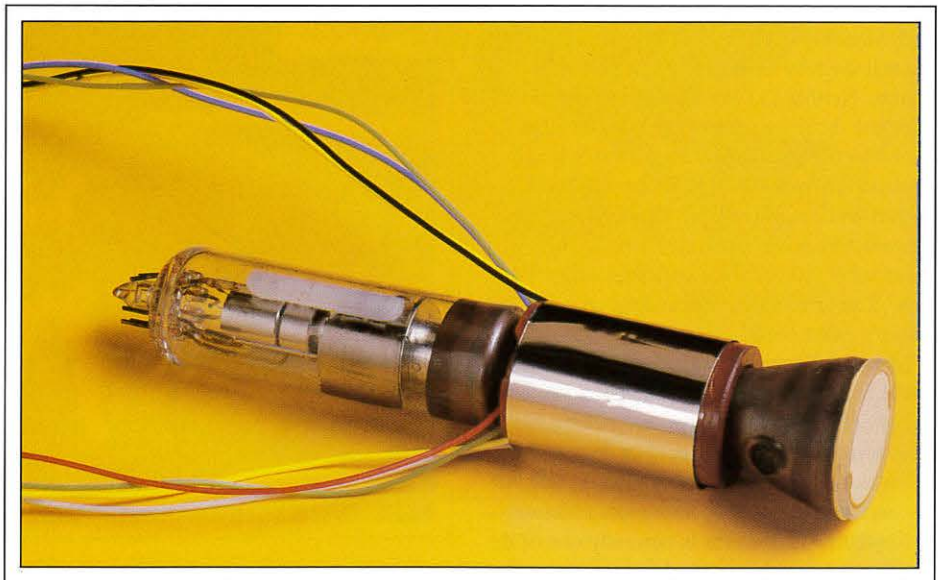

Fig. 4: Photo of assembled snap-and-wrap yoke.

WinTron, Inc.

Table 1: Performance of a 7-mm Snap-and-Wrap Yoke for a Neck-Down CRT

	Vertical	Horizontal
Sensitivity (mA)	95	135
Inductance (mH)	3.5 - 4.5	1.0 - 1.4
Resistance (Ω)	21 - 27	11 - 17

These "snap-and-wrap" yokes have alignment features on both the vertical and horizontal sets which allow the two individual halves of each to seat properly. The halves are then taped with Mylar or glued together to hold their form (Fig. 4). Thanks to the use of tightly specified multipiece molds, the sensitivity of the system is not degraded compared to traditional yokes. The epoxy impregnation fills all voids between wires with minimal overmolding. This allows the system to sit directly on the tube and the vertical coil form to rest directly on top of the horizontal coil form.

Thus far, we have produced coils for 13- and 7-mm applications, but with mold-design modifications this process is also applicable to other sizes of neck-down tubes. The snap-and-wrap yokes have performed well compared to the more labor-intensive wrap-around yokes that must be assembled on the CRT by a yoke manufacturer.

One example of a customer's requirements that have been met successfully by a 7-mm snap-and-wrap yoke are shown in Table 1. Various operating temperatures were also checked, as the snap-and-wrap units effectively survived thermocycle from -50°C to $+70^{\circ}\text{C}$. The resonant frequency of the units was equal to or greater than conventional neck-down units.

Although they are an improvement over earlier snap-and-wrap models, current units are not without problems. Even though the snap-and-wrap is very easy to assemble, the sensitivity can be degraded by as much as 7 mA if the coils are positioned incorrectly along the length of the neck of the tube.

The future of easily assembled neck-down yokes seems bright, with new applications appearing in emerging and current markets. As the process becomes more refined, unit specifications will improve as well. Perhaps this evolution in deflection technology will help lengthen the life of the custom and semi-custom CRT. ■

SID '98

Anaheim, California
Anaheim Convention Center
May 17-22, 1998

DMTC '98

San Jose, California
San Jose Convention Center
January 20-22, 1998



MEASURING DISPLAYS OR LEDs? WE GIVE YOU THE ENTIRE SPECTRUM!

For every application there is a perfect solution. Our range of scanning and array based spectrometers offers a new perspective in production testing, quality control and research.



With the capability to measure all of the optical parameters you need within seconds, our Compact Array Spectrometer, the CAS140B, is ideally suited for testing displays and LEDs. A wide selection of interchangeable measurement adaptors can be attached by optical fibers for unrivaled versatility.

As the market leader in LED optical test instrumentation, innovation has always been our strength. It is re-assuring to know that we offer you complete solutions for spectroradiometry, photometry, transmission/reflection and polarization measurements.

FOR THE PERFECT SOLUTION - PHONE, FAX OR E-MAIL US TODAY!

**INSTRUMENT
SYSTEMS**
OPTISCHE MESSTECHNIK

Headquarters: Instrument Systems GmbH, Germany, Phone +49-89-4549430
Fax +49-89-45494311 E-mail: info@instrumentsystems.de
North America: Instrument Systems, Canada, Phone 613-729-0614
Fax 613-729-9067 E-mail: info@instrumentsystems.com
Internet: www.instrumentsystems.com

Circle no. 11

Inspection and Test Techniques for FPD Manufacturing

Testing techniques are becoming highly accurate, and some are fast enough to be incorporated in high-volume production lines.

by Tim Knuth and Jeff Hawthorne

FLAT-PANEL MANUFACTURERS have begun to adopt automated testing, repair, and inspection into their mass-production lines. In the past, manufacturers have utilized a variety of test methods and test points within the manufacturing process, including particle inspection, film thickness, substrate thickness, and the electrical and visual characterization of cells and modules. Let's take a look at some of the important test and inspection methods currently being used on the color-filter (front) and TFT (back) plates in the TFT-manufacturing process (Fig. 1). Figure 1 shows a general overview of the manufacturing process and where inspection, test, and repair fit into the process, although this article will focus on what goes on prior to cell assembly.

Test Strategies

Test strategies depend upon the test method selected and its location in the manufacturing process. The test method's throughput, defect-detection accuracy, and defect-classification accuracy will dictate which test strategy is best for a particular test point.

Tim Knuth is product marketing engineer at Photon Dynamics, 6325 San Ignacio Ave., San Jose, CA 95119; telephone 408/360-3037, fax 408/226-9910, e-mail: timk@phodyn.com. Jeff Hawthorne is Photon Dynamics' vice president of development; telephone 408/360-3026, fax 408/226-9910, e-mail: jeffh@phodyn.com. This article is adapted and condensed from the authors' applications seminar given at SID '97 in Boston, May 14, 1997.

One strategy is process monitoring, a detailed test of the device that produces an accurate defect classification. Test equipment and methods for process monitoring usually have low throughput, and this often leads to the adoption of lot sampling - testing a number of devices within a given lot. The sampling number should be large enough to statistically represent the state of the entire lot.

Full-lot testing requires high-throughput test methods that must be able to detect defects accurately and classify them as fatal vs. non-fatal. Full-lot testing produces a go/no-go result, but the test methods used will not usually provide the level of defect characterization provided by process-monitoring methods. Manufacturers may opt to use full-

lot testing methods in conjunction with processing-monitoring methods.

Optical Inspection

Optical-inspection systems can detect particles or patterning defects on the array plate and distinguish between pattern defects and particles with over 85% accuracy. Optical inspection can distinguish between fatal and non-fatal defects for a large variety of defect types. Correlating optically inspected defects with functionally inspected defects can classify defects as fatal or non-fatal. Performing optical inspections between process steps can identify faulty processes through statistical process-control methods.

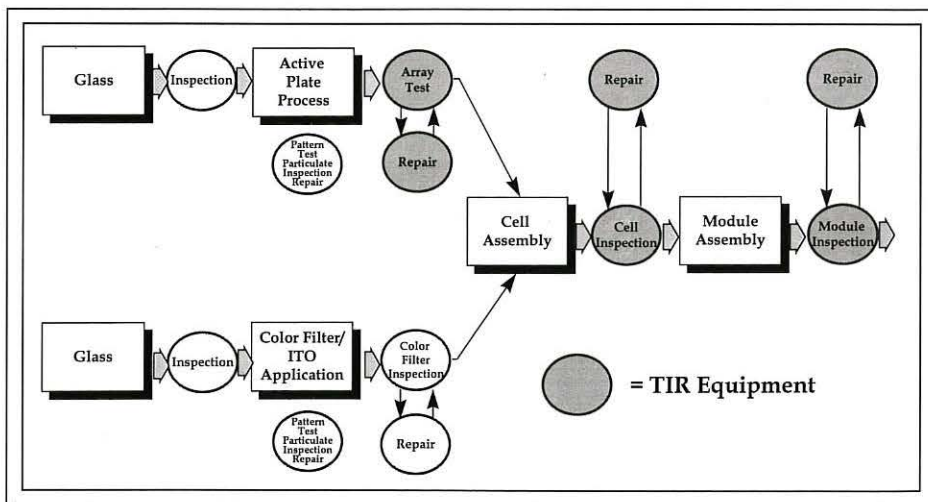

Fig. 1: This general overview of LCD fabrication shows where inspection, test, and repair fit into the manufacturing process.

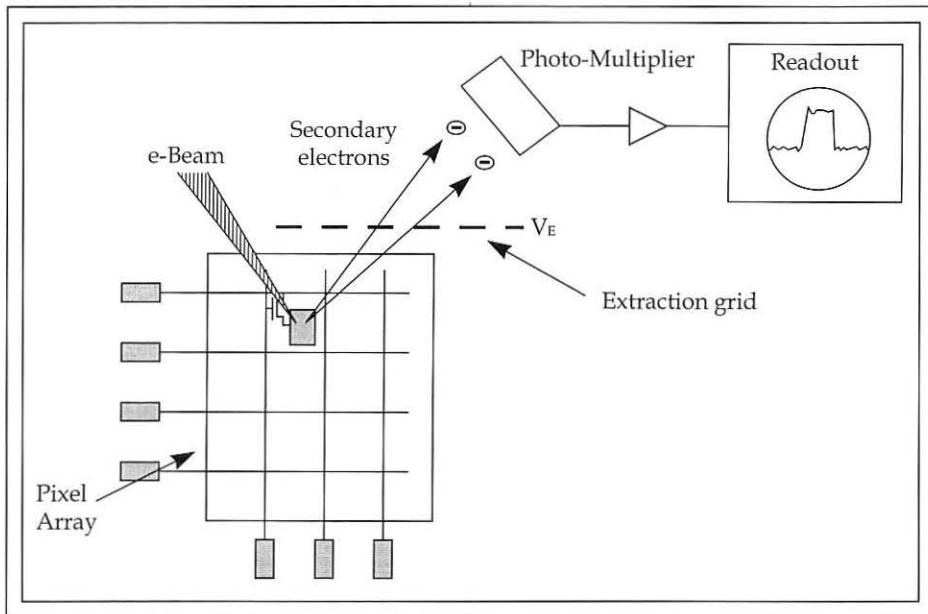

Fig. 2: Electron-beam testing drives the TFTs individually, but requires contact only with the ESD shorting bars.

LCD manufacturers utilize optical-inspection methods for bare-glass inspection, film-thickness measurement, and film-patterning inspection. We will concentrate on describing film-pattern inspection methods. The two common methods for such inspections are optical image processing and digital image processing.

Optical Image Processing

Optical image-processing inspection systems are based on coherent optical Fourier-transform systems. A typical application for such systems is defect detection of repetitively patterned devices. The device under inspection is illuminated with collimated, coherent laser light. The transmitted or reflected light is collected by a lens, which produces the Fourier transform of the object at the lens's back focal plane. A spatial filter located at the transform plane blocks the known frequencies present in the object image. Particle and pattern defects passed by the filter are detected by a fast analog detector.

Advantages of this technique include:

- High inspection speed due to the simplicity of the electronics. The optical filter performs all complicated image processing.
- Relatively large depth of field can be achieved, and it is possible to detect defects with relatively low resolution.

Disadvantages include:

- Defect classification (distinguishing between fatal and non-fatal defects) is difficult.
- Border areas outside the active array can not be tested because the Fourier transform limits the inspection to repetitive patterns.
- With coherent (laser) illumination, very small changes in the thicknesses and refractive indices of thin films can lead to the "detection" of false defects.
- Laser intensity may become unstable over time.

Digital Image Processing

Digital image processing takes the output from a CCD camera, digitizes it, stores it in memory, and then applies a number of image-processing algorithms to locate defects. Both the electronics and the algorithms are complicated, and the optical subsystems have to be designed together with the defect-detection algorithms. This results in a complex and expensive system.

The most common method of digital image processing is to use step-and-repeat optics and pattern-recognition algorithms. In this method, the TFT substrate is placed on a large chuck, and the stage steps and repeats under the optical subsystem in a serpentine loop. At each site, the CCD camera captures an image

and transfers the image to the image processor, which processes the image to identify defects. One common method is to compare the captured digital image to one that is stored in memory and to recognize appropriate differences as defects.

Advantages of this technique include:

- The ability to distinguish between fatal and non-fatal defects.
- High sensitivity for complicated images.
- Repeatable and predictable defect detection because of the digital nature of the procedures involved.

Disadvantages include:

- Extensive engineering effort is required to develop the electronics, optics, and image-processing algorithms.
- High system cost because of system complexity.
- Low throughput due to step-and-repeat image capture.

Electrical Test

In most cases, optical inspection is not sufficient to determine the performance of a TFT array early in the manufacturing process. The higher quality demanded by the consumers of the TFT displays is requiring manufacturers to detect TFT threshold-voltage variations between subpixels, high ON resistance, leaking TFTs, pre-assembly mura, pixel and line defects, and variations in pixel capacitance. Fortunately, techniques for detecting these defects and measuring these TFT characteristics have been developed and are now in use.

To cover functional test requirements, several electrical-testing techniques have been developed over the years. These include ohmic/continuity testing, charge sensing, forward admittance sensing, electron-beam testing, and voltage imaging.

Ohmic/Continuity Testing

The simplest electrical-continuity test uses mechanical probes to contact both ends of each drive and source line - gate and data. Open lines can be found by simple measurement of the line resistance. If the lines are interdigitated, and all even lines are connected to one shorting bar and all odd lines to a second shorting bar, adjacent shorts can also be detected. Shorts between gate and data lines can be detected if separate shorting bars are provided for gate and data lines. This tech

test and inspection

nique is simple, fast, and cheap, but it does not permit TFT characterization or detection of individual pixel defects.

Charge Sensing

More complex techniques use a probe to contact all lines at the same time. Signals are applied to the probe to write charge to each pixel and to read back the stored charge. Charge sensing differs from continuity testing in that the circuit can write charge on any cell in the active array, hold the charge on the cell for a predetermined length of time, and then read the charge from the cell and measure it. This sequence of events is called a *basic test*. By varying the parameters of the test – such as gate pulse height and width, and hold time – it is possible to extract the gate threshold voltage, cell-charging time constant, cell OFF current, and other cell parameters.

It is possible to scan through every cell quickly, writing and reading charge in each cell. Cells that do not store enough charge, and cells that store too much charge, are marked as suspected cells for detailed analysis using other tests. This constitutes a rapid go/no-go test.

Cells that do not store enough charge may have a charge-leakage path, which can be checked using a leakage-current test. The source of leakage current can be the transistor channel, insulation films, or the liquid-crystal material. Another possible source of inadequate charge storage is a transistor that is not providing sufficient ON current. The transistor performance can be tested using a dynamic threshold test and a charging time-constant test.

Advantages of this technique are:

- Each pixel is selected by the addressing signals and tested individually.
- Many pixels can be tested in parallel.
- The technique allows substantial characterization of TFTs and can test them after they have been passivated, as well as after assembly with the top glass.

Disadvantages are:

- The probes are complex and must be different for each panel design/configuration.
- The coupling of shorting bars for electrostatic discharge (ESD) protection must come from resistive elements or diode pairs.
- New-generation poly-Si TFT displays with integrated drivers cannot be tested



Photon Dynamics

Fig. 3: Photon Dynamics' in-process-test mass-production system (IPT-MPS) uses voltage imaging for array testing and is configured with a three-cassette robot.

by this technique because the control lines are loaded by the connections to the driver circuit.

Forward Admittance Sensing

In forward admittance sensing, an electrical probe makes contact with the gate and data lines. A combined ac and dc test signal is applied to each gate line, and currents are measured simultaneously by detectors connected to many data lines. The transfer ratio is admittance, whose phase components give conductance and capacitance. Conductance and capacitance differences are sensitive measures of faults because they vary only slightly over the area of a panel.

The presence of ESD shorting bars (guard rings) can complicate the electrical measurement performed in the admittance method. Basically, the ESD shorting bars must be designed with forward admittance sensing in mind by including resistive elements.

Defect detection using this testing technique covers all of the basic electrical defects, including line opens, shorts, TFTs with high ON resistance, and leakage of the storage capacitor. Many of these defects can be located and identified, as well as simply detected.

A test setup might employ a probe array to contact all gate lines as well as a second set of probes to contact all the data lines. An alternative method is to use a block of probes that

contact only a small number of gate and data lines and step across all of the contact points.

Advantages of this technique include:

- Fast go/no-go testing.
- Many pixels can be tested in parallel.
- Allows substantial characterization of TFTs and can test them after they have been passivated, as well as after assembly with the top glass.

Disadvantages of this technique include:

- The probes are complex and must be different for each panel design/configuration.
- The coupling of shorting bars for ESD protection must come from resistive elements or diode pairs.
- New-generation poly-Si TFT displays with integrated drivers cannot be tested by this technique because the control lines are loaded by the connections to the driver circuit.

Electron-Beam Testing

Electron-beam testing is a relatively new technology that is now entering the arena for TFT-array in-process testing. Electron-beam (e-beam) testing drives the TFTs individually, as does the charge-sensing technique, but requires contact only with the ESD shorting bars (Fig. 2). Resistors or diode pairs between lines and shorting bars are not required, and there is no moving test head, only an electromagnetically controlled e-beam that senses pixel voltages.

The technique directs a focused e-beam onto the different pixels of a display matrix using an electromagnetic deflection system. The beam is switched on and off by a blanking system to form e-beam pulses that supply current to each individual ITO pixel electrode. Therefore, the ITO electrode must not be passivated.

There are two different testing modes. In the first, a beam pulse of fixed duration supplies equal charge to each pixel. The second mode uses controlled charging of pixels or lines up to a pre-set voltage, which automatically adapts the beam pulse's duration. The secondary electrons (SE) generated during the beam pulses reveal the voltages on the pixels in the first mode and are used to control the charging in the second mode. This voltage measurement utilizes the kinetic energy of the SEs. The SEs initially have a low kinetic energy but are accelerated by a voltage difference between the probed pixel and the detector. Their final kinetic energy at the detector thus depends on the voltage of the probed pixel.

These two mechanisms of charging and voltage reading are used to generate several different test routines that can be tailored to the needs of particular displays and technologies. In addition, voltages can be applied to the shorting bars to switch TFTs on or off, which generates additional test conditions.

Metal-insulator-metal (MIM) elements can be tested by grounding all lines and charging the pixel electrode to the threshold of the MIM. Test sequences can also be developed for TFT arrays with integrated drivers and can detect both array and driver problems.

Advantages of this technique include:

- Shorting-bar contact can be made.
- Allows substantial characterization of TFTs.

Disadvantages include:

- Passivation layers attenuate measurements.
- E-beam scanning and read reduces testing speed.
- High-vacuum test environment affects throughput.

Voltage Imaging

Voltage imaging measures the characteristics of a TFT array by indirectly measuring the actual voltage distribution on the TFT pixel ITO. This measurement technique simulates the performance of the array as if it were assembled into a TFT cell (Fig. 3).

The voltage imaging system in its most basic form includes an electro-optical (EO) modulator, an imaging objective lens, a CCD camera, and an image processor. The EO modulator is placed approximately 10–20 μm above the surface of the TFT array. A voltage bias is driven across the ITO surface on the EO modulator, and the modulator capacitively couples the charge that is locally distributed on the TFT array and the ITO plane. Depending on the electric-field strength, the transmission of the modulator will change. Light reflected into the top of the modulator passes through it and reflects off a mirror that is part of the modulator. The objective lens images the reflected light onto a CCD camera, and an image processor digitizes the CCD-camera signal. A calibration image taken prior to the measurement image establishes a gain value to convert digitized image gray levels into voltage levels.

Voltage imaging has the advantage of testing the array using drive patterns and voltages similar to those used for driving the display. As a result, the technique is able to characterize the actual performance of the TFT array just as if it were coupled with its mating top plate, injected with LC material, and driven as a cell. Pixel, line, and mura defects can be identified.

Other FPD technologies, such as FED, MIM, and passive-matrix arrays, can also be tested using voltage imaging. Recent studies have shown that voltage imaging can be used to measure the performance of an FED cathode array prior to joining the array to the anode plate - and without damage to the cathode emitter tips during exposure to the atmosphere and testing.

Where Are We Now?

Flat-panel manufacturers have begun to adopt sophisticated testing methods into their mass-production lines. The accuracy of the methods has improved to the point where manufacturers have begun to utilize them for statistical process control. ■

Please send new product releases or news items to Information Display, c/o Palisades Institute for Research Services, Inc., 201 Varick Street, New York, NY 10014.

The Smart Choice in Digital Video Generators

ASTRO VG-826

True "Digital" Video Generator

Dot Clock to 60MHz / 120 MHz

Operated directly from a PC or with "Remote" Frontpanels

Very Compact & Lightweight

8 Bits resolution / pixel / color



If you service, repair, evaluate or engineer modern Flat Panel Devices, the Astro VG-826 is the Digital Generator for you.

It's small and light enough to fit in your briefcase, yet has the performance to drive any single or multiplexed Flat Panel Device with a resolution of 24 bits per pixel up to a multiplexed frequency of 120MHz.

It can be programmed and operated from a PC or with the RB-646 "Remote" frontpanel or operated only with the RB-614C Controller.

Make the *Smart Choice*...

Contact TEAM.

Call 1-800-338-1981 or visit us at <http://www.team-systems.com>

TEAM
systems

"Test And Measurement Technology"

Circle no. 12

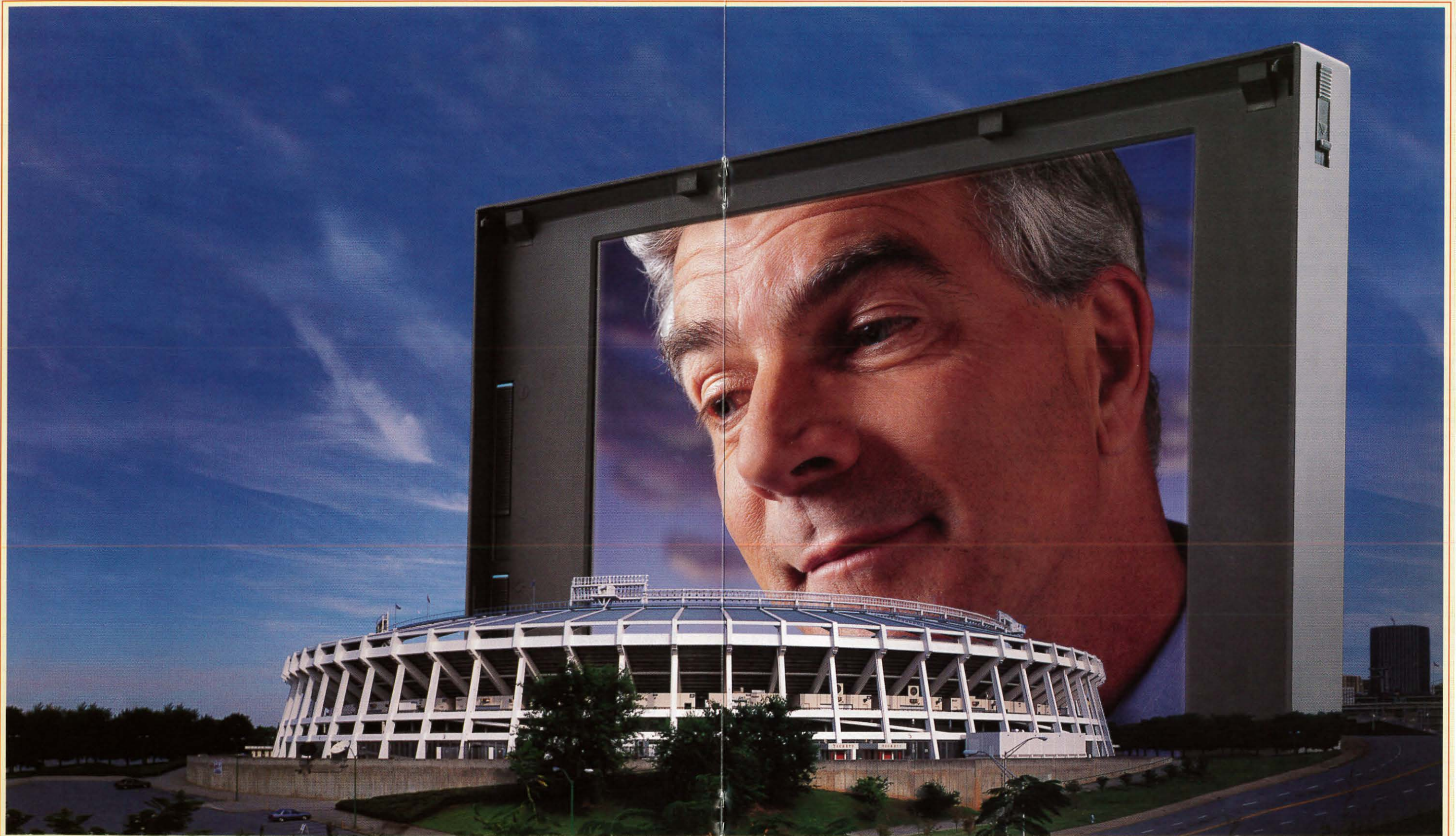

Our LCD's have grown.

In the two short years since we entered the market, Samsung has become one of the world's leading TFT LCD manufacturers.

As you may know, we already offer a line of TFTs 20% brighter

and with 30% more color saturation than the closest competitors.

We'll be following up soon with more products that are—well—larger than life. Including a 13.3" XGA notebook panel, and XGA and SXGA

panels actually designed for desktop monitors—in a whopping 14" and 15.1".

And hey, with the desktop impending, can the coliseum really be far behind?

Onward and upward, guys.



STILL A *Generation* AHEAD.

Viewing-Angle Improvements for LCDs

Several techniques have dramatically increased the viewing angles of LCDs, but there's more to come – and soon.

by Philip J. Bos and Ken Werner

DESPITE the many attractive features of twisted-nematic (TN) and supertwisted-nematic (STN) liquid-crystal displays (LCDs), their designers have always had to wrestle with the technology's inherent anisotropy: its optical characteristics vary greatly with viewing angle.

For notebook-computer displays, traditionally the technology's big-dollar application, it used to be possible to shrug off the viewing-angle problem. After all, the typical user *wants* to keep his or her head directly in front of the screen and not look at it obliquely. The lack of off-axis viewability was even regarded by many users as a desirable security feature. (To borrow the punch line from an old joke about a leading software developer's major product, "It's not a bug, it's a feature.")

But as laptop screens grew to 12 and 13 in. on the diagonal – and as LCD desktop monitors with screens up to 20 in. began to reach the market – it became impossible to sustain such casualness about the problem. The rea-

Philip J. Bos is an associate director of the Liquid Crystal Institute and Associate Professor of Chemical Physics at Kent State University, P. O. Box 5190, Kent, OH 44242-0001; telephone 330/672-2511; fax 330/672-2796; e-mail: pbos@kent.edu. Ken Werner is the Editor of Information Display Magazine. This article was adapted from a portion of Professor Bos's seminar, "Emerging Liquid Crystal Technologies," given on Monday, May 12, 1997, in Boston, Massachusetts, as part of SID '97.

son comes down to simple geometry. When the viewer's eyes are 20 in. away from a 12-in. display and centered on one corner, the opposite corner is seen at a 30° angle. This angle is more than enough to produce color shifts as the eyes aim at different points on the screen – a real problem even for a single user sitting in front of the display.

Let's look in some detail at the nature of the viewing-angle (VA) problem, at the clever techniques currently used to solve the problem, and at the emerging technologies that promise to do the job more effectively or more cheaply.

The Viewing-Angle Problem

The viewability of an image on a given LCD depends not only on the viewing angle but also on the image itself. In the case of a typical TN-LCD, the intensity of each saturated state (black and white) at 30° from a line normal (perpendicular in all directions) to the screen is relatively constantly independent of azimuthal angle (Fig. 1); i.e., the light intensity doesn't change too much at the 30° angle regardless of whether that angle is oriented toward 12, 4, or 8 o'clock, or anywhere in between. For the white state, this is shown by the centered circular curve that is at 100%

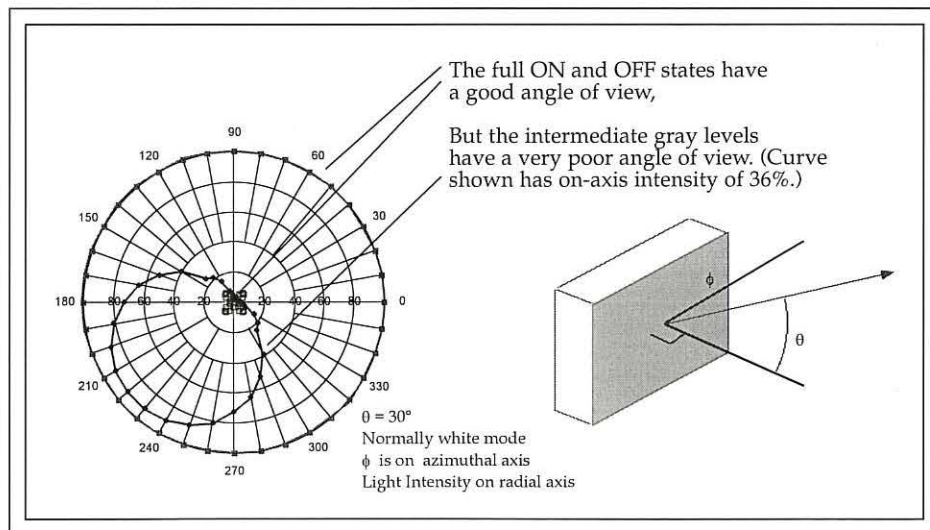

Fig. 1: The viewability of an image on a given LCD depends not only on the viewing angle but also on the image itself. In the case of a typical TN-LCD, the intensity of each saturated state (black and white) at 30° from a line normal to the screen is relatively constantly independent of azimuthal angle. But for an intermediate gray level, the circle is clearly not centered.

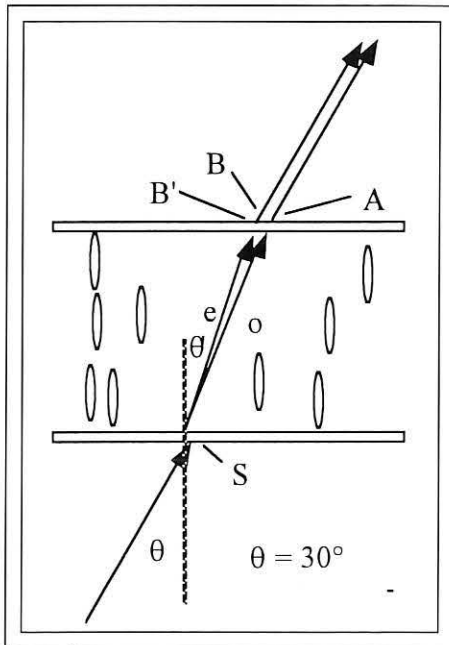

Fig. 2: In the black state of a typical LCD, the directors are somewhat parallel to the screen normal, which helps account for the good viewing angle.

at all angles; and for the black state, by the small circular curve that is also symmetrical around the center of the polar-coordinate plot. So, for an image consisting of only blacks and whites, this LCD would have an acceptable viewing angle.

But with an intermediate gray scale (36% in this case), the circle is very clearly *not* centered. The tremendous variation with angle means that with change in the direction from which the user views the display the mid-gray will vary from deep black to quite a bright white. For example, if this gray level is on the green subpixels in an RGB color display, colors will shift drastically.

To see how this undesirable behavior arises, let's review a little optics. When a lightwave enters a type of material classified as birefringent, it splits into an ordinary and an extraordinary ray. These rays travel at different velocities, and therefore a relative phase shift develops between them as they propagate through the material. The intensity of light transmitted by the device depends upon this phase shift, which turns out to vary approximately as $\sin^2\theta$, where θ is the angle between the wavefront normal of the light ray and the liquid-crystal director. The VA char-

acteristics of a TN device can be understood in a crude way simply by considering that the variation in the transmitted light intensity as a function of the angle of view is closely related to $\sin^2\theta_c$, where θ_c is the angle between the wavefront normal of the light and the director located at the mid-layer of the cell.

In the black state of a typical LCD, the directors are somewhat parallel to the screen normal. The on-axis light intensity of the black state is close to 0%, and the intensity at 30° is less than 10% (Fig. 2). This VA dependence is not too bad because $\sin^2\theta_c$ does not vary rapidly with θ_c in the vicinity of 0°.

But for gray levels, the VA is poor. For a 50% gray level, the directors can be about 45° to the screen normal. In this case, if the viewpoint shifts to 30° off-axis, the intensity can change to about 90% (depending on the tip direction), from a mid-gray to a rather bright white. All of this is explained nicely by the \sin^2 dependency of the phase shift.

The director in the center of a TN cell always lies in a plane that is at a 45° angle to the rub direction [Fig. 3(a)]. The arrows show off-axis light in this plane, which, as we now know, would have good viewing characteristics for saturated states and bad characteristics for gray level. Assuming that this plane is situated along the vertical direction, moving the eyepoint from left to right in the horizontal plane generally does not produce major intensity variations, but the nature of the angular dependence produces serious fall-offs when the eyepoint is moved up and down in the vertical plane. This is exactly what is experienced with actual displays: extreme variations of intensity with even small vertical changes in eyepoint [Fig. 3(b)] and not much of a horizontal problem except for black [Fig. 3(c)]. So one major problem with the VA of a TN device is the variations in the gray-level intensities as the viewer's eyepoint moves vertically in front of the display. Hopefully, this can be seen to be

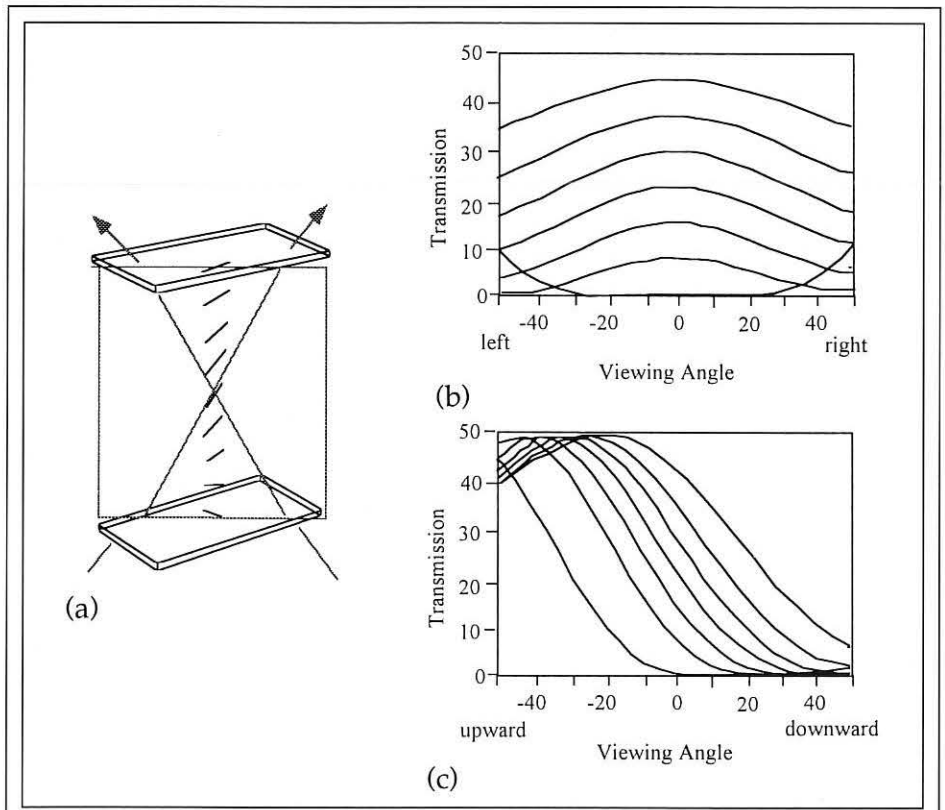

Fig. 3: (a) The director in the center of a TN cell always lies in a plane that is at a 45° angle to the rub direction. Assuming this plane is the vertical plane, moving the eyepoint from left to right in the horizontal plane generally does not produce major intensity variations (b), but the nature of the angular dependence produces serious fall-offs when the eyepoint is moved up and down in the vertical plane (c).

due to the $\sin^2\theta_c$ dependence of the phase shift, which is especially dramatic in this case.

Although the deviation from zero transmission (true black) is not large compared to the intensity shifts of the gray levels in the vertical plane, it is enough to substantially degrade contrast ratio and color fidelity. But even worse is the fact that the black level crosses some of the gray levels. This image inversion creates the appearance of a photographic negative when the display is viewed from unfavorable angles. It is a characteristic that display designers like very much to avoid.

Our goal, therefore, is to improve the vertical, improve black, and at least try not to do much harm to the horizontal angular variation of the other intensity levels.

Multidomain TN-LCDs

The problem with traditional TN-LCDs is that the director is in a particular direction, and the phase shift changes as a function of this direction. If we could create a device in which each pixel had two domains, each having its director separated from the other's by a 180° rotation about the cell normal, we might be able to compensate for the undesirable angular behavior in traditional cells. This idea was suggested by Tanuma at Fujitsu and K. H. Yang at IBM in the early 90s.

There are a number of ways to create two-domain cells. One way is to use a single rub direction on the alignment layer and two different LC materials to produce the two director pretilts. Another is to use a single LC material and two different rub directions.

Sugiyama and his co-authors from Stanley Electric and the Tokyo University of Agriculture and Technology calculated two-domain results [Fig. 4(b)] and compared them with those for one domain [Fig. 4(a)]. Horizontally, there aren't substantial differences. Vertically, the two-domain technique basically adds a mirror image of the one-domain curve and averages it with the original. The resulting curve is symmetrical, but there is still image inversion as the levels all converge and the image disappears at 45° . (It's not disastrous if all gray levels shift together, but it is serious if the levels cross and contrast inverts.)

Solving the Image-Inversion Problem

A few years ago, Shunsuke Kobayashi, now at the Science University of Tokyo in Yamaguchi, Japan, realized that a lot of the image

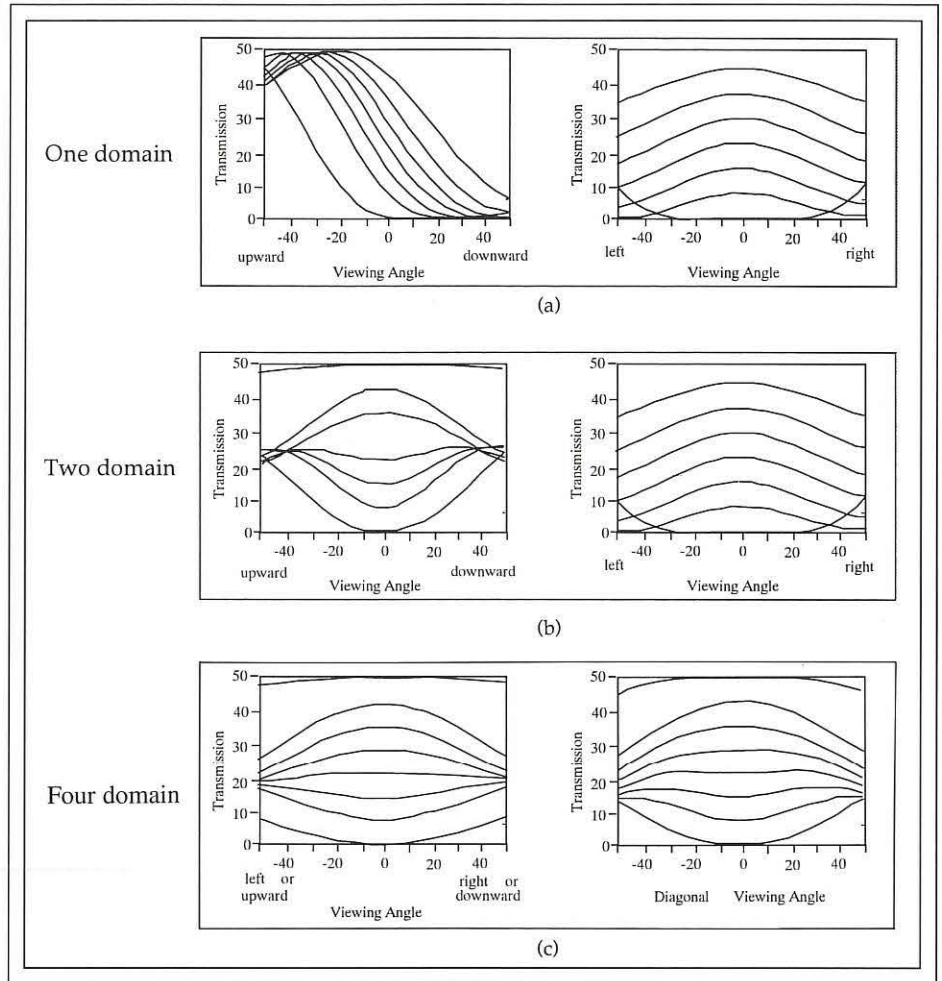

Fig. 4: A comparison of calculated two-domain results (b) with one-domain results (a) does not show substantial changes in horizontal viewing angle. Although the curve is symmetrical vertically, there is still image inversion as the levels all converge and the image disappears at 45° . But using four domains does away with the image-inversion problem (c). [Data from Sugiyama et al., SID Intl. Digest Tech. Papers, 919 (1994) and Sugiyama, Jpn. J. Appl. Phys. 34, 2396 (1995).]

inversion will go away if more than two domains are used. In fact, four domains do a very good job [Fig. 4(c)], while eight or more domains do no better. This is an elegant concept, but how could a multidomain cell actually be fabricated? The answer may not be obvious at first, but there are several techniques for making TN multidomain devices.

What is complicated about making a four-domain device is the need to rub small adjacent areas of the alignment layer in several different directions. So, Kobayashi said, instead of the rubbing, add a chiral additive to the LC material and don't rub at all. This very clever

approach to making a multidomain device - which is called the amorphous TN approach - actually has simpler processing than the conventional TN cell we started with.

Amorphous TN devices are effective and simple, but amorphous domains are not always as well controlled as we would like. The domains can get a bit large, giving the display a sandy texture when viewed off-angle. An amorphous-like approach that controls the domain size at the cost of increased structural complexity is the ASM mode. A structure of polymer walls literally puts each pixel in a box and produces alignment of the cell.

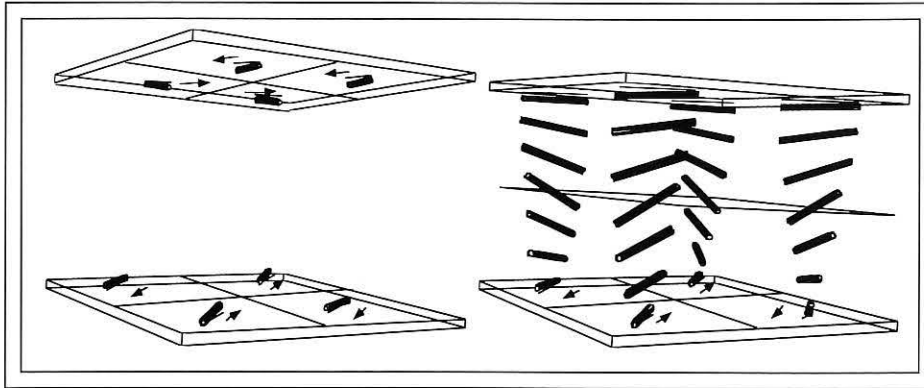

Fig. 5: Kent State University's variation on the four-domain LCD theme has two subdomains with a left-handed twist and two with a right-handed twist.

Kobayashi has also suggested the super-multidomain (SMD) four-domain device with patterned alignment. The subpixels are four domains of the same twist sense, each rotated by 90°.

At Kent State University (KSU), we have developed a variant of the SMD approach that is somewhat simpler in its processing (Fig. 5). Two of the subpixels have a left-handed twist, two have a right-handed twist, and standard TN cell processing can be used. The SMD and KSU devices, along with several other variants that have been built, perform as Kobayashi predicted. Specifically, there is no image inversion.

Fixing the Black State

With four-domain devices we can now get good viewing angles with white and gray levels, and we have cured the dreaded image-inversion (or level-inversion) problem. But one-, two-, and four-domain devices all have poor VA for the black state (Fig. 4). (The bottom curves in each panel do not stay at zero transmittance.)

If just the curves of Fig. 4 are considered, this may not appear to be a great problem because, even at 40° off-axis horizontally, the transmission is only about 10%. Unfortunately, when the intended level is zero, 10% is a huge number. It dramatically degrades contrast ratio and color fidelity.

What is the origin of this poor black performance? There is one special direction in a birefringent material called the optic axis. Along this axis, light in any polarization experiences no retardation. As light tips off this axis, the extraordinary index of refraction gets larger than the ordinary index, birefringence

effects are produced, and the light is elliptically polarized. As we have seen, in TN-LC materials the optic axis coincides with the LC director.

In principle, for the ideal case of the dark state of a normally white TN device in which the director is everywhere aligned with the cell normal, this problem can be solved with a simple negative-birefringence film. Such a film cancels the birefringence effect in the LC cell, and it should work for any angle of view.

Negative-birefringence films were developed at a variety of places, including ALCOM (Advanced Liquid Crystalline Optical Materials), a consortium of Kent State University, the University of Akron, and Case Western Reserve University that is a U.S. National Science Foundation Science and Technology Center. Films are now available from a variety of sources. But when first tried in practice, negative-birefringence film didn't work as well as anticipated: leakage at large VA was improved but not eliminated.

The reason is that in real TN cells the LC director - and the optic axis - is not uniformly aligned along the cell normal in the voltage-applied state, which is usually the black state (Fig. 6). So, our solution is not suitable for what we should be correcting. Our assumption was wrong. (Actually, we knew it was wrong when we started. Applied physicists are very fond of making simplifying assumptions and seeing how far they can go with them. It's a good way of getting started on a difficult problem.)

There are two approaches to rectifying this situation. First, we can more closely match the optic axis of the negative-birefringence film to the director distribution of the TN cell

in the field-applied state. This sounds complicated, but Hiroyuki Mori at Fuji Film Ltd. was able to provide a much improved black level using only two film layers with a more complex optic-axis distribution. Fuji does this with discotic liquid crystal, one with negative birefringence that has been polymerized to form a film.

Because the gray-level changes are subtle, it may not be obvious that fixing the black state will make the display look very much better. But the visual effect is dramatic because color purity and contrast are vastly improved. This is a very important development, and, as far as display manufacturers are concerned, all it requires is adding a film.

The second approach is to match the LC directors to the film; *i.e.*, instead of using a TN device, use a vertically aligned device that matches the simple film. Such a device has negative dielectric anisotropy: the director rotates away from the direction of the applied electric field instead of aligning with the *e*-field as in a TN device. In the field-removed state, the directors in a vertically aligned device are vertical and the device produces a beautiful black state.

How can the director be kept from tipping away randomly when the field is applied? In their color superhomeotropic (CSH) LCD, Stanley Electric utilized a fringing field created by putting a hole in the pixel electrode. The fringing field produces multidomain alignment, a technique that has been extensively explored and perfected by IBM's Alan Lien. Also, Kent State's Vithana has shown a four-domain vertically aligned device that uses pattern alignment.

In-Plane Switching

Is there a way of improving the VA characteristics of a TN cell by rethinking its operation rather than by compensating for its deficiencies? The problem with the TN cell is that its LC directors are pulled out of the plane of the display when the electric field is applied, producing substantial variations in $\sin^2\theta$ and the phase shift.

In a traditional TN cell, the rubbing directions on the top and bottom plates are perpendicular to each other, which gives the LC director a 90° twist from one plate to the other. Ideally, polarized light entering the cell follows this twist and passes through the analyzer, which is at 90° to the polarizer on the

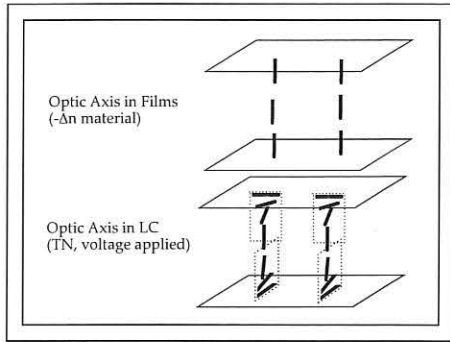

Fig. 6: The initial attempts to correct the black state with negative-birefringence film didn't work as well as anticipated because, in real cells, the LC director – and the optic axis – is not uniformly aligned along the cell normal in the voltage-applied state.

opposite plate. Applying a field between the two plates tips the directors out of the plane of the display, providing less twist and allowing less light to pass through the analyzer.

If tilting directors out of plane is the cause of our problem, can a method be found to provide optical switching while always keeping the directors in the plane of the display? The answer is yes, and this very creative approach is not new. It was first presented by Günter Baur at an LC workshop held in Freiburg, Germany, in 1971. The insight virtually disappeared from view, however, until Hitachi showed a prototype display based on the in-plane switching (IPS) principle at the 1995 Asia Display in Hamamatsu. (Baur was named a Fellow of the Society for Information Display at SID '97 in Boston.)

For IPS, the rubbing axes on the two plates are the same, and there is no twist in the direction of the LC directors from one plate to the other. The polarization of the light does not change as it passes through the cell, and we have a normally OFF device if the polarizer is aligned with the rub direction and the analyzer is crossed to it. When a field is applied to the cell, it is applied between interdigitated electrodes that are both on the bottom plate. The field lines are mostly in plane through a significant portion of the cell, which applies a twist to the cell directors and the plane of polarization. We thus get switching with the cell director being *always* in the plane of the cell. The angle θ is always 90° , and the variation in the phase shift is small even for large VAs because the variations in $\sin^2\theta_c$ are small for variation of about 90° .

The VA of IPS cells is very good, but at the cost of a somewhat reduced aperture ratio and luminance. As a result, IPS displays are being marketed only for non-portable applications such as desktop monitors.

The interest in IPS devices has inspired a rethinking of conventional TN devices. TN-LCDs are generally designed around the first interference maximum, which provides the highest transmittance for the brightest possible display. But IPS has demonstrated that people will tolerate obtaining 70% of maximum transmittance in return for excellent VA in some applications, and TN designers know that if they design around a thickness less than the first interference maximum, they too can get much better VA with about 70% of optimum brightness. Samsung's Jianmin Chen showed these results clearly in his recent SID '97 paper.

Pi-Cells

Conventional electro-optical effects require multidomains because the director configurations for gray levels are not symmetric around the cell normal. One solution is an electro-optical effect with a more symmetrical director configuration. Such a configuration can be fabricated by modifying a tunable birefringence (TB) LC cell. In such a cell, off-axis light tips closer to the optic axis in one half of the cell (decreasing the phase shift) and farther from the optic axis in the other half of the cell (increasing the phase shift) (Fig. 7). In this way, the cell uses its internal symmetry to provide optical self-compensation.

Such cells do not have the complications of multidomain approaches, and work at Tek-

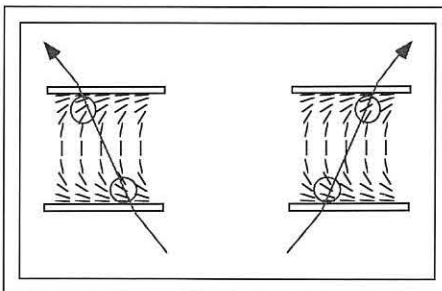

Fig. 7: The simplest way to improve viewing angle is to use an electro-optical effect with a more symmetrical director configuration, which can be done by modifying a tunable birefringence (TB) LC cell. The internal symmetry of these pi-cells provides optical self-compensation.

tronix and by T. Uchida at Tohoku University has demonstrated good VA and fast response. IBM Japan has shown prototypes using this approach. Fuji's Mori has considered further improvements by combining his negative-birefringence film with a pi-cell, and gave an invited talk at IDRC in September. His results showed that an excellent VA can be achieved with this approach.

Looking Ahead

Multidomain and IPS devices and discotic films for improved VA can be found in some commercially available displays now, and are likely to be used in more displays in the future. But these approaches may also be supplemented by vertically aligned multidomain devices or pi-cell devices.

Displays using TN cells operating below the first interference maximum to gain VA for a modest sacrifice in transmittance should also be attractive to manufacturers. It is a simple approach that offers a clean tradeoff. Battery-operated applications require the luminous efficiency of conventional TN; desktop and industrial displays need wide VA and can tolerate less luminous efficiency.

With so much activity in LCD design, there will be a new generation of displays with better performance and, in some cases, lower cost. ■

20

98

JANUARY

Display Works 98:

SAN JOSE, CALIFORNIA
JANUARY 20-22, 1998

- An international conference addressing all aspects of Display Manufacturing including:
- Flat Panel and CRT Manufacturing
- Display Materials
- Manufacturing Equipment
- Cost Reduction and Yield Improvement
- Industry Forecasts
- Investor Presentations
- International Standards

Check what you need in your display analysis system:

- ✓ flat panel tests
- ✓ CRT tests
- ✓ easy upgrades (hardware and software)
- ✓ standard for ISO, NIDL, and VESA testing
- ✓ optimized for fast, accurate, and automatic testing with many packaged test suites

If you checked all of the above, you have chosen the Microvision SS200 Family of Display Analysis Systems

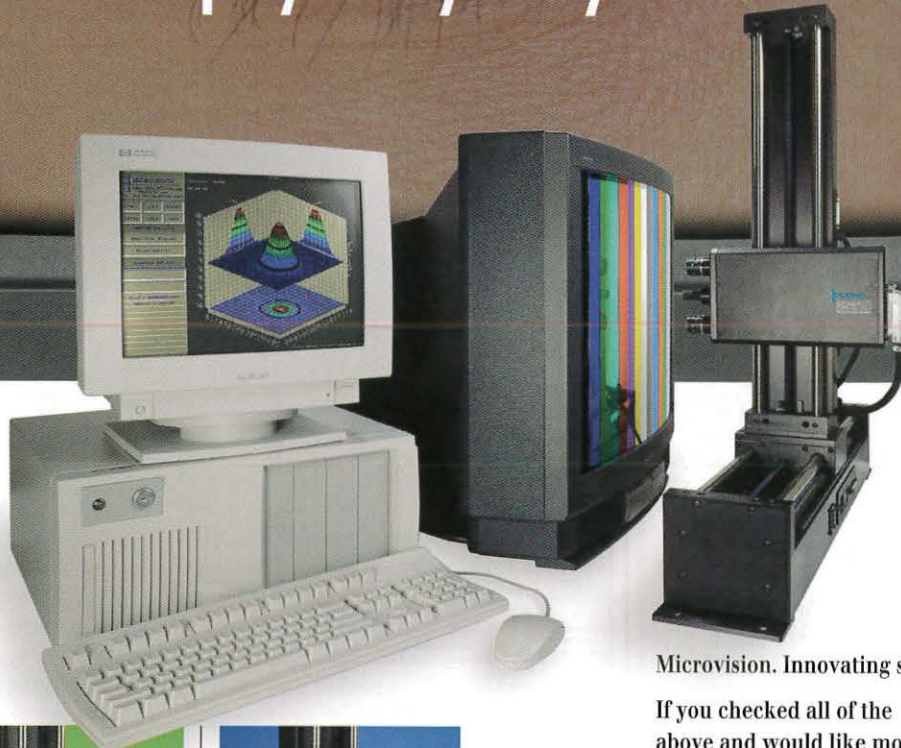

With the SS200 family, you can precisely, automatically, and completely measure display performance—and that includes flat panels.



SS200

Complete turnkey system with computer, 6-axis positioner, monitor, software, and SS200 camera system. Automatically performs spatial and luminance measurements.



SS210

You can easily field upgrade to the more powerful SS210 package, which provides all SS200 functions, plus an integrated spectrometer for spectral analysis and color measurements. Includes response time measurement capability.



SS220

For flat panel testing, a field upgrade to the SS220 is easy. The SS220 provides spectrometer-based off-axis measurement, color analysis, color shift and luminance testing. Coupled with the SS210, this is the most comprehensive test system ever offered—at a fraction of the cost of individual test instruments. All tests are performed at NIST-traceable accuracy.

Microvision. Innovating since 1985.

If you checked all of the above and would like more information, call Microvision at (800) 951-5188.

MICROVISION

Dedicated to the Needs of the Display Industry

550 High St., Suite 108 / Auburn, CA 95603
Tel: (916) 888-8344 / Fax: (916) 888-8349
Toll Free: 1 (800) 931-3188
Email: microvsn.com
Web site: <http://www.microvsn.com>

International Reps:
Japan - ARGO CORP., 06 359 3566
Taiwan - SUPERLINK TECH., 02 705 7090
Korea - B & P INT'L, 02 546 1457

Circle no. 14

Backlighting for Direct-View LCDs

There's a lot to think about when selecting an LCD backlight, but many solutions are available.

by Ian Lewin

SELECTING BACKLIGHTS for direct-view liquid-crystal displays (LCDs) is a more complex task than it may appear to be at first (Fig. 1). Part of the difficulty is the large number of backlighting techniques that are available, but the best available technique can only be selected when the end use of the display is fully understood and appropriate specifications - including the cost - are developed. Let's start off with some lighting parameters that are important for backlighting and then move on to the art of selecting backlights.

The *efficacy* or *luminous efficiency* [given in lumens per watt (lm/W)] is an important parameter for lamps, backlights, and complete display modules. The parameter indicates the amount of luminous output produced by a system for each watt of electrical power consumed. It is particularly important for notebook computers and other battery-operated systems since it directly affects the useful operating time from a single battery charge.

Designing an LCD module with high efficacy is particularly challenging because an LCD panel itself has low *transmittance*, which is the percentage of light that passes through the panel. Typical transmittance values for high-resolution LCD systems are given in Table 1. A substantial portion of the untransmitted light is absorbed in the polarizers and color filters of typical LCDs.

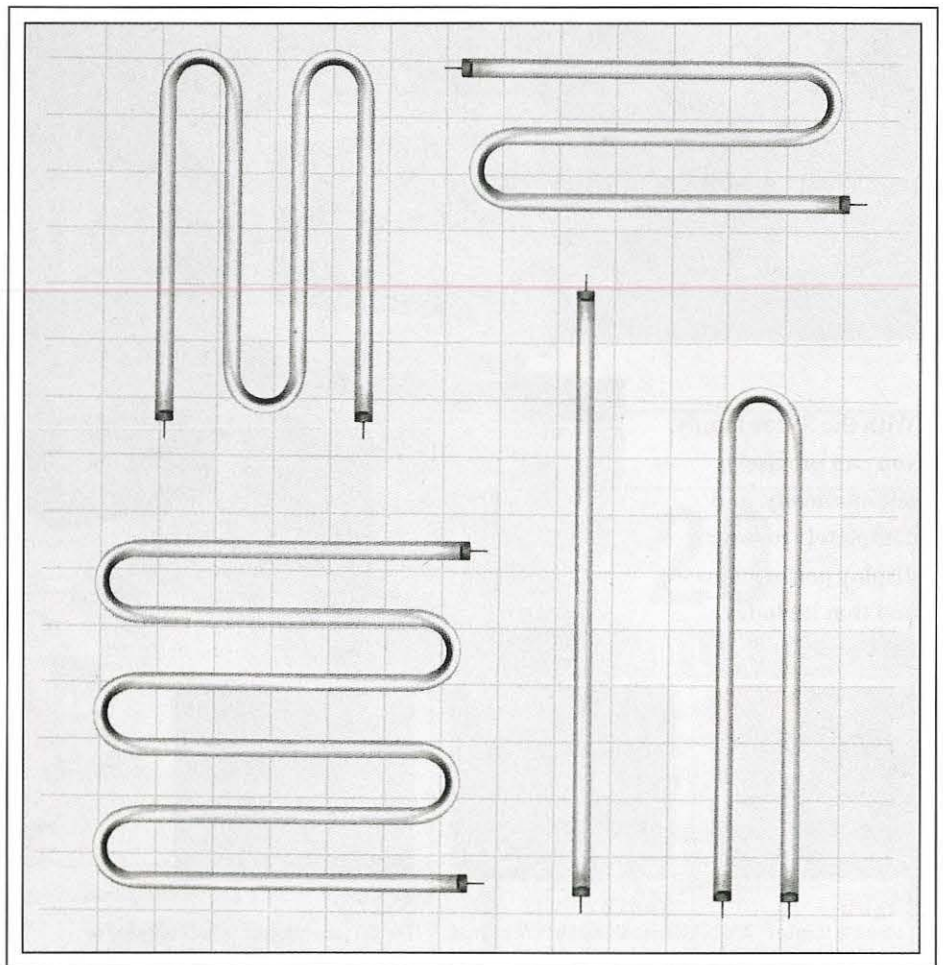

Fig. 1: Straight, U-shaped, and serpentine fluorescent lamps are only the first of many choices to be made when designing an LCD backlight. (Illustration courtesy of LCD Lighting, Orange, Connecticut.)

Ian Lewin is President of Lighting Sciences, Inc., 7830 E. Evans Rd., Scottsdale, AZ 85260; telephone 602/991-9260, fax 602/991-0375, e-mail: lightsci@worldnet.att.net.

Vendors (partial listing)

LCD Fluorescent-Lamp Manufacturers/Suppliers

Light Sources, Inc.

P.O. Box 948, Orange, CT 06477; 203/799-7877

Voltarc Tubes, Inc.

400 Captain Neville Dr., Waterbury, CT 06705; 203/578-4600

JKL Components Corp.

13343 Paxton St., Pacoima, CA 91331; 1-800-421-7244, 818/896-0019

I. I. Stanley

Los Angeles Sales Office, 2660 Barranca Pkwy., Irvine CA 92714; 714/222-0777

Osram Sylvania

100 Endicott St., Danvers, MA 01923; 508/777-1900

LCD Lighting, Inc.

37 Robinson Blvd., Orange, CT 06477; 203/795-1520

Flat Fluorescent-Lamp Manufacturers

Flat Candle Co.

4725 B, Town Center Dr., Colorado Springs, CO 80516; 719/573-1880

Thomas Electronics, Inc.

100 Riverview Dr., Wayne, NJ 07470; 973/696-5200

Sanyo Electric Co., Ltd.

1-1, Dainichi-Higashimachi, Moriguchi, Osaka 570, Japan; +81-069-003-516

Holographic Materials Manufacturers

Physical Optics Corp.

20600 Gramercy Pl., Bldg. 100, Torrance, CA 90501; 310/320-3088

Kaiser Optical Systems, Inc.

371 Parkland Plaza, P.O. Box 983, Ann Arbor, MI 48106; 313/665-8083

Color Temperature

Light is spontaneously produced when a radiator such as a filament is heated to a high temperature. The color of the light emitted by such a "blackbody" radiator depends upon the temperature. Relatively low temperatures produce light biased to the red end of the spectrum, while high temperatures produce a bluish light. "Color temperature," expressed in Kelvin, therefore defines the spectral distribution of a filament lamp and is an important parameter.

The term is also widely applied to non-filament lamps, which is confusing. For non-filament lamps, it would be more accurate to substitute the expression "correlated color temperature." This is the temperature on the locus of blackbody temperatures (when these temperatures are plotted on the CIE chromaticity diagram) that is closest in appearance to the color coordinates of the non-blackbody radiator being characterized. While this can

be a useful way to provide a general description of the color of a fluorescent or discharge lamp, it will differ radically from that of a blackbody source having the same color temperature. Because there is an infinite number of spectral power distributions that can produce any given correlated color temperature, the term is of limited use in LCD applications.

Light-Loss Factors (LLFs)

Virtually all light sources exhibit lumen depreciation, or a reduction in light output, with burning hours. This usually takes the form of a fairly rapid fall-off during the first 100 or so hours of lamp operation, and then a gradual reduction to the end of life. Different forms of lamps have different lumen-depreciation rates, so this should be addressed when selecting lamps for a backlight design. Lamp manufacturers usually have lumen-depreciation curves available for their products.

Lamp Life

All light sources have a life quoted by their manufacturers, but this life is statistically determined and does not represent a guarantee of the life of a particular lamp. The most commonly used definition of lifetime is the 50% failure point: the statistical point at which 50% of an "average" batch of lamps will fail. Thus, many lamps will fail prior to the rated lifetime.

In critical applications, such as in avionic systems, the practical life of the lamp may be considerably shorter than the rated life because lamp changeout is necessary for safety reasons to reduce the possibility of lamp failure in use.

Certain lamps have very long life but exhibit drastically reduced lumen maintenance late in life. Therefore, there may be a practical end-of-life when the lamp has not extinguished but is producing such a reduced light output that it is no longer able to meet luminance-level specifications.

Claims of lamp life must thus be treated with caution, and analyzed along with lumen-depreciation data and a recognition of the possible effects of premature lamp failure.

Luminance Uniformity

Uniformity of luminance is generally expressed as a plus/minus percentage, but there is no universal definition of uniformity. While the plus/minus percentage expresses the allowable departure from the mean luminance, the precise definition of maximum, minimum, and mean is unclear. For backlighting systems using parallel fluorescent tubes, the maximum luminance is usually taken at a point directly in front of a tube, while the minimum is measured at the nearest point between tubes. But the true minimum usually lies at a corner of the LCD or along an edge. The method of measuring near-

Table 1: Transmittances of High-Resolution LCD Systems

LCD Type	Transmittance (%)
Active matrix, color	2-4
Active matrix, monochrome	10-12
Passive matrix, color	4-8
Passive matrix, monochrome	10-15

backlighting

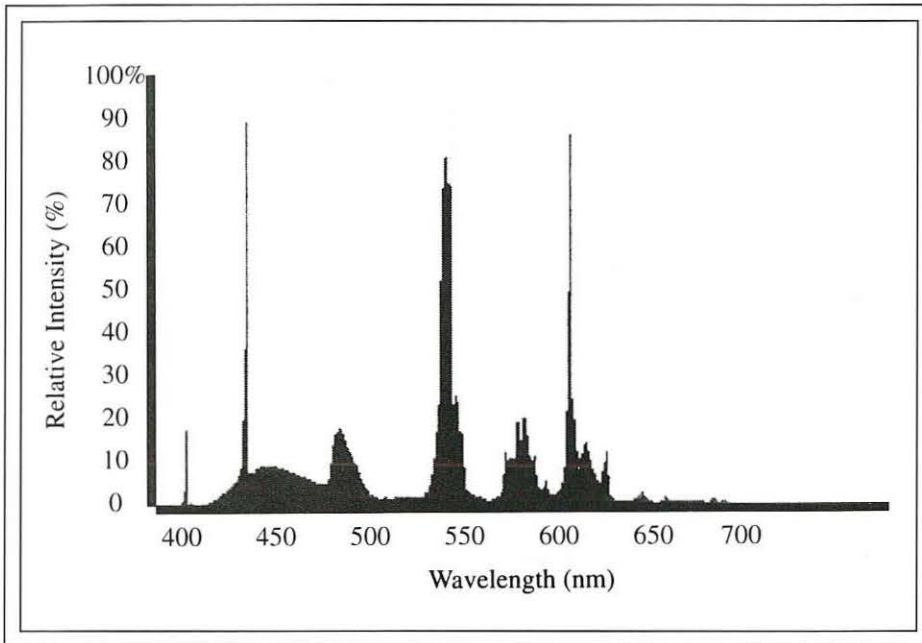

Fig. 2: Tri-phosphor lamps show peaks in their spectral power distribution (SPD) at three distinct points in the spectrum. (Illustration courtesy of LCD Lighting, Orange, Connecticut.)

est maximum and minimum points is suitable for characterizing uniformity in terms of a striping problem, but it does not define overall uniformity.

Fluorescent-Lamp Characteristics

Most of today's LCD-backlighting systems rely on fluorescent lamps. These lamps work similarly to conventional fluorescent lamps used for the general illumination of buildings, but have been miniaturized for LCD applications.

The major components of a fluorescent lamp are the glass tube, the end electrodes, and the phosphor coating on the inside of the tube. The tube contains low-pressure mercury gas and a small amount of inert gas to assist in lamp starting. Applying a high voltage across the electrodes ionizes the gas and initiates a current flow between the two electrodes. This flow causes the gas to emit radiation, predominantly in the ultraviolet (UV) region (253.7 nm), which excites the phosphor on the inner wall of the tube. The wavelengths of light emitted depend on the type of phosphor used and are usually over a broad spectrum, producing a generally white appearance.

Spectral Power Distribution

By alteration of the chemical composition and

mix of the phosphors, the spectral power distribution (SPD) of the emitted light can be changed. "Cool" colors are produced by phosphors designed to emit a high proportion of blue light, while "warm" colors are generated by increased emission in the yellow and red spectral bands.

Over the last few years, considerable research has led to phosphors that convert UV radiation to visible light much more efficiently and provide improved lamp color. For commercial lighting applications, phosphors have been developed that produce SPDs which yield good color rendition. Among these are the various tri-phosphor lamps that show peaks in their SPD at three distinct points in the spectrum (Fig. 2). Manufacturers are interested in fluorescent-lamp phosphors with emission peaks close to the peak spectral transmittance values of the color matrix filters used in LCDs. By coordinating lamp spectral output with LCD spectral characteristics, it should be possible to considerably improve system efficiency. Lamps with enhanced spectral characteristics for LCD applications are now available.

Ballasts

Electrical discharge through a gas must be controlled externally to prevent the flow of a

very high electrical current that will burn out the lamp almost instantaneously. The lamp circuit therefore contains a ballast, which acts as a current-limiting device and also provides the high starting voltage needed for ionization. The limited current flow is kept close to that specified for steady-state operation of the lamp.

Ballasts may be either magnetic or electronic. The magnetic ballast is a highly reactive transformer that creates a high voltage in its secondary coil to start the lamp, but then limits the current flow because of its very high reactance. The electronic ballast uses electronic components to achieve a similar result.

Hot or Cold Cathode?

Fluorescent lamps come in hot- and cold-cathode types. The hot-cathode lamp uses electrodes that are small heater coils. A small voltage is applied across each coil, heating the electrode and thermally emitting a large quantity of electrons. This is an efficient method of creating the electron flow through the tube because it keeps the voltage drop at the cathode (the cathode fall) to only a few volts.

Cold-cathode lamps don't have a coil; their electrodes consist of unheated cylinders or plates. They exhibit a high cathode fall during operation and are thus less efficient than hot-cathode lamps.

Both hot- and cold-cathode lamps are being applied in LCD-backlighting systems. The

Table 2: Characteristics of Hot- and Cold-Cathode Fluorescent Lamps

Parameter	Hot Cathode	Cold Cathode
Starting voltage	Lower	Higher
Life (thousands of hours)	5-15	10-20
Vibration and impact resistance	Poorer	Better
Cathode losses	Low (15 V)	High (150 V)
Efficacy*	Higher	Lower

*Efficacy, given in lumens per watt, depends on many characteristics, such as arc length, tube diameter, power loading (W/cm), phosphor type, and lamp shape, in addition to cathode type. Complete performance specifications are available from various manufacturers.

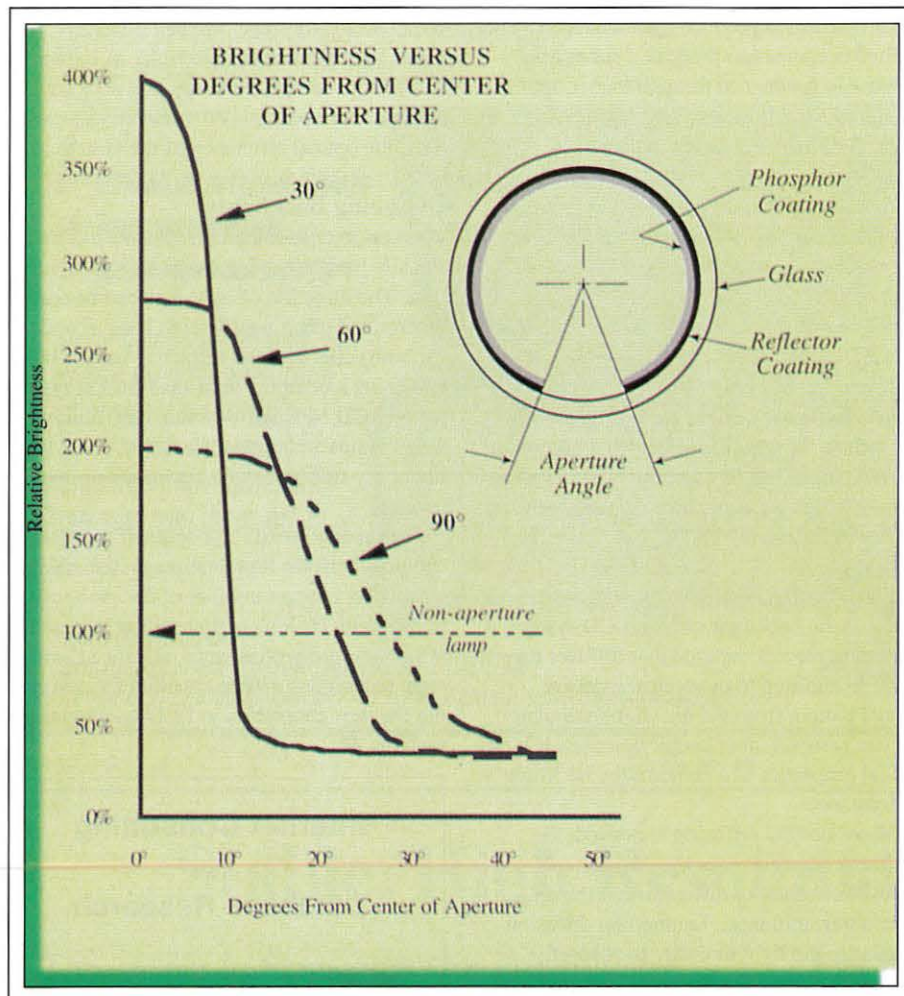

Fig. 3: Aperture lamps have a small gap in the reflector and phosphor layers that allows light to be emitted through the gap. Inter-reflection of light within the tube causes the output of light through the window to be increased up to 10 times that of a non-reflectorized lamp, which allows the light projected into an edge-lighting system to be increased substantially. (Illustration courtesy of LCD Lighting, Orange, Connecticut.)

two lamp types have substantially different characteristics, with each having its own advantages and disadvantages (Table 2).

Temperature Characteristics

Fluorescent lamps have high-temperature sensitivity in both their starting voltages and lumen output. Low temperatures increase the breakdown voltage (the voltage required to start the lamp) and ballasts designed for starting under normal ambient temperature are likely to be unsatisfactory.

At both low and high temperatures, fluorescent lamps give substantially reduced lumen output. The actual temperature characteristics

are dependent upon the specific lamp type, and must be checked prior to selecting lamps that must operate over a wide range of ambient temperatures. Supplemental heating circuits may be required.

Aperture Fluorescent Lamps

Normal fluorescent lamps emit light in all directions, with approximately equal intensity in directions perpendicular to the lamp surface. In certain applications, such as edge lighting, the goal is to project light into a thin sheet of transmitting material. In such applications, it may be advantageous to use an aperture or reflector fluorescent lamp, a modi-

fied type that creates a sharply increased intensity in a narrow range of directions.

Aperture lamps have a white reflective layer between the phosphor and glass tube that covers most of the lamp surface. A small gap in the reflector and phosphor layers allows light to be emitted through the gap (Fig. 3). Inter-reflection of light within the tube causes the output of light through the window to be increased up to 10 times that of a non-reflectorized lamp. This allows the light projected into an edge-lighting system to be increased substantially.

Light-Control Systems

All LCD-backlighting systems must produce relatively uniform luminance in a plane parallel to and behind the LCD. There are many techniques for light control that help produce backlights which approach the ideal flat sheet of light – and more are under investigation.

Flat Fluorescent Panel. The simplest form of flat fluorescent panel, which has been widely used, depends on a serpentine lamp, which creates the effect of a row of parallel tubes. The spacing between the tube segments affects the uniformity of the light, with a wide spacing producing unsatisfactory bands of high and low luminance. This may be overcome by using a diffuser between the lamp and LCD, which evens out the luminance. Very good uniformity requires a material that strongly diffuses the light, but the diffuser's transmittance is generally reduced if the diffusion is high. So, there is a tradeoff between uniformity and optical efficiency – and, therefore, the luminance level.

Recently, special lamps have been developed that operate on principles similar to those of the fluorescent tube, but which are different in construction. One form of flat fluorescent lamp is similar to the bent serpentine

Table 3: Typical Specification of LCD Backlight for Computer Monitor

Active Area	11 × 7 in.
Average luminance	4000 fL
Luminance uniformity	±15%
Dimming range	100:1
Lamp life	10,000 hours

backlighting

lamp except that it is not a tube. Formed from front and rear glass moldings that are joined together, a serpentine discharge path is created in a one-piece lamp.

Another flat fluorescent lamp creates a sheet of plasma that activates the fluorescent phosphor with good uniformity. These lamps are available in a variety of sizes up to 6 × 8 in.; the thickness is typically 0.40 in. or less.

Manufacturers' claims for the performance of flat fluorescent lamps vary depending upon the variety. A luminance of 20,000 cd/m² (6000 fL) has been claimed for a serpentine-channel lamp, while the claimed luminance of flat plasma lamps ranges from 3500 cd/m² (1000 fL) to 10,000 cd/m² (3000 fL).

Edge-Lighting Systems. Edge-lighting methods do not use lamps behind the LCD. Instead, they use lights mounted around the periphery of the display and an optical system to carry and emit light behind the LCD. Because the light-generating length is limited by the size of the LCD edges, and because edge-lighting has relatively low optical efficiency, edge-lighting techniques do not generally produce very high luminance. However, they have the considerable advantage of very shallow depth because there are no lamps behind the LCD. This makes the method applicable to products such as laptop computers, where a thin profile is important and power consumption is low.

One way of getting light from an edge-lighting system behind the display is through a *light pipe*. A sheet of plastic is placed behind the LCD and fluorescent lamps are placed along one or more edges of the sheet. Light enters the sheet and is transmitted across by total internal reflection. Light is emitted only when rays hit a discontinuity in the plastic surface that interrupts the total internal reflection.

A popular kind of discontinuity is an array of bumps or dots on the surface of the plastic sheet facing the LCD. The spacing of the dots determines the luminance in a particular area, so dot density can be varied to change the luminance. A high dot density is used in areas remote from the lamp and a low dot density is used near the lamp to provide luminance uniformity. A diffuser may be needed between the light pipe and the LCD to hide the dot pattern.

A prismatic form of light pipe has been developed, in which prisms are formed in the

plastic surface to produce light emission. This method is claimed to produce a substantial increase in luminance through higher optical efficiency. Luminances up to 5500 cd/m² (1600 fL) have been produced.

Reflector Systems. The development of narrow-diameter straight fluorescent lamps permits the fabrication of thin backlighting systems based on parallel tubes. We now have reflectors that capture light from the sides and rear of the tubes, which do not face the LCD, and redirect that light to the low-luminance areas between the fluorescent lamps. Reflector designs have been produced that reduce the striation effects to a minimum, and the stripes can be completely removed by placing a high-transmittance diffuser between the backlight and the LCD.

Light-Control Materials

Between the backlight and the LCD system, it is usual to place a material that diffuses the light. In addition to producing a smooth lighted pattern from the backlight, the material can perform other useful functions if it has optical properties that enhance the backlight's performance.

Where normal diffusion is desired, the thickness and density of the diffuser will affect the amount of diffusion and the diffuser's transmittance. Lambertian diffusion distributes the light intensity in proportion to the cosine of the viewing angle, and thus provides constant luminance.

Usually, however, the vertical and horizontal angles of view are limited to substantially less than ±90°. By concentrating light in a generally forward direction, the intensity and luminance close to the 0° viewing angle can be substantially increased, although the width of the effective viewing angle is decreased. This can be achieved by using prismatic lenses or holographic materials instead of a diffuser.

New materials for controlled diffusion are the result of holographic processes. Such materials allow the degree and pattern of diffusion to be specified, rather than evolving from the random scattering of light produced by conventional diffusers.

Experimenting with different diffuser types is normally required when developing backlighting systems because each type of backlight design has its own characteristics regarding viewing angle, luminance uniformity, and

luminance level. The designer generally wants to implement a uniformity of luminance that just meets specifications and does so with the minimum possible diffusion so as to maximize the optical efficiency of the system.

Designing Backlights

The design of illumination systems has traditionally been carried out using ray-trace methods. The direction of light rays can be readily determined using well-known laws of optics for both reflective and refractive media, but designing a complex light-distribution system for an LCD backlight - which may involve many lamps and optical elements - with traditional ray-tracing can be extremely time-consuming.

Fortunately, personal-computer software can now perform illumination-system design, permitting a larger number of design iterations. With customers demanding increasing efficiency and performance, advanced software techniques will be essential for designing the next generation in LCD-backlighting systems. ■

Internet Consulting

and

Database Research

Get on the "Net." Training, lectures, Web sites, and consulting by the former Executive Director of the Internet Society. Visit the SID homepage at

<http://www.sid.org>

Database research. Patent Searches, Technical Literature, Competitive Analysis, Market Research, Demographics

H.L. Funk Consulting
7 Diane Court
Katonah, NY 10536

Telephone/Fax: 914-232-3530

E-mail:

consult@hlfunk.com

LAMINATORS

Spire Corporation offers large-area vacuum lamination equipment for high throughput processing of:

- **LCD/AMLCD flat panel displays**
- **Touch screen panels**
- **Optical filters and polarizers**

Originally designed and widely used for production of photovoltaic modules, Spire laminators apply uniform temperature and pressure over areas up to 4 m².

Spire Corporation
One Patriots Park/Bedford, MA 01730-2396/USA
Phone 617-275-6000/FAX 617-275-7470/email: spire.corp@channel1.com



SPI-LAMINATOR Models 240, 350, 460, & 660:

- 1 m² to 4 m² process area
- 2.5 cm maximum lamination stack thickness
- Built-in vacuum system
- Conveyor load/unload option
- Clean room compatible
- Custom engineering available

Programmable Processing:

- Temperature _____ 180°C (max.)
- Pressure _____ 1 atm (max.)
- Chamber Vacuum _____ 1 mm Hg
- Automatic or Manual Cycles

For equipment specifications and additional information, please contact Mr. Keith Matthei at 617-275-6000



spire

Circle no. 16

Stable, High Resolution Probing

The Leader in Semiconductor Probing now offers a Flat Panel solution; Model 2250.

- Built-in Vibration Isolation Table.
- Large area 15" x 24" microscope movement range.
- Independently positionable platens with manipulator "track drive" for maximum flexibility.
- Fast pull out chuck for easy load and unload.

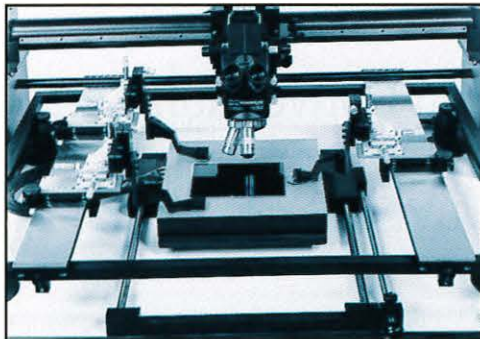

14" x 14" panels standard, larger available

Track driven manipulators with lock downs

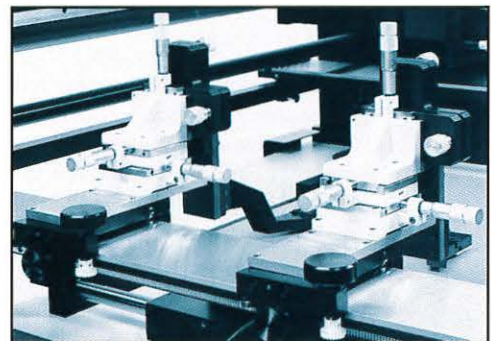

Choose standard vacuum or magnetic base manipulators. Manipulator driven link arms support:

- Probe Cards
- Microwave Probe Heads

Phone: 702-882-2400 • Fax: 702-882-7694
Visit our web site: www.micromanipulator.com

THE MICROMANIPULATOR
COMPANY, INC.

Circle no. 17

Gerome Manufacturing Company, Inc.

An Industry Leader in
Magnetic Shielding Products



Gerome Manufacturing Company is a leading producer of diversified technical specialties which are distributed to a broad industrial market.

Gerome fabricates the most advanced and highest quality magnetic alloys available in a multitude of geometric patterns to provide efficient high

attenuation shielding for cathode ray tubes, photo multiplier tubes, transformers and sensitive instrumentation.

With nearly 40 years experience, the firm uses advanced metal working techniques to form, shape, weld, heat treat and finish various materials.



Gerome Manufacturing Company, Inc.

403 N. Main Street • P.O. Box 747
Newberg, OR 97132
Phone: (503) 538-8356
Fax: (503) 538-1090
E-mail: gerome@teleport.com

Oliver Road • P.O. Box 1089
Uniontown, PA 15401
Phone: (412) 438-8544
Fax: (412) 437-5608

Circle no. 18

CRT Display Engineer

n•vision inc., a premier designer and manufacturer of commercially available 3D immersive display systems, seeks enthusiastic can-do individual to assist in production of CRT-based head mounted display systems. Requires strong analog troubleshooting skills. Experience with CRT power supplies and deflection circuits is essential. LCD experience a plus. BSEE and 8 years experience required. Successful candidates must be able to work flexible, extended hours as needed.

We offer competitive wages, medical and dental insurance and 401K. Equal Opportunity Employer. Send your cover letter and resume in confidence. For more information about n•vision, please visit our website at <http://www.nvis.com>



n•vision inc.

Attn: KR
7680 Old Springhouse Road
McLean, VA 22102
Fax: 703.903.0455
e-mail: sales@nvis.com
No phone calls please.

CAREER OPPORTUNITY

Abbie Gregg, Inc. (AGI), is looking for a Flat Panel Display Process Engineer to join our talented team of high-tech consultants. AGI provides consulting services such as process engineering, cleanroom layout, equipment specification, factory modeling, contamination control and tool installation/hookup for our clients in all fields of display manufacturing.

The Process Engineer we are seeking would be responsible for bringing their technical expertise and working with our in-house support staff to successfully complete various projects.

Travel to client sites both domestically and internationally. Technical, communication and project management skills are required. Experience with AMLCD, Plasma, OLED, FED or other display technology is necessary.

Please send resumé to:

Abbie Gregg, Inc.
Attn: Richard Baron
1130 E. University, Suite 105
Tempe, AZ 85281-8403
Fax (602) 446-8001

AGI is a drug-free, EOE workplace



AGI

Abbie Gregg, Inc.

SID '98

Anaheim, California

Anaheim Convention Center

May 17-22, 1998

Mark Your Calendar Now!

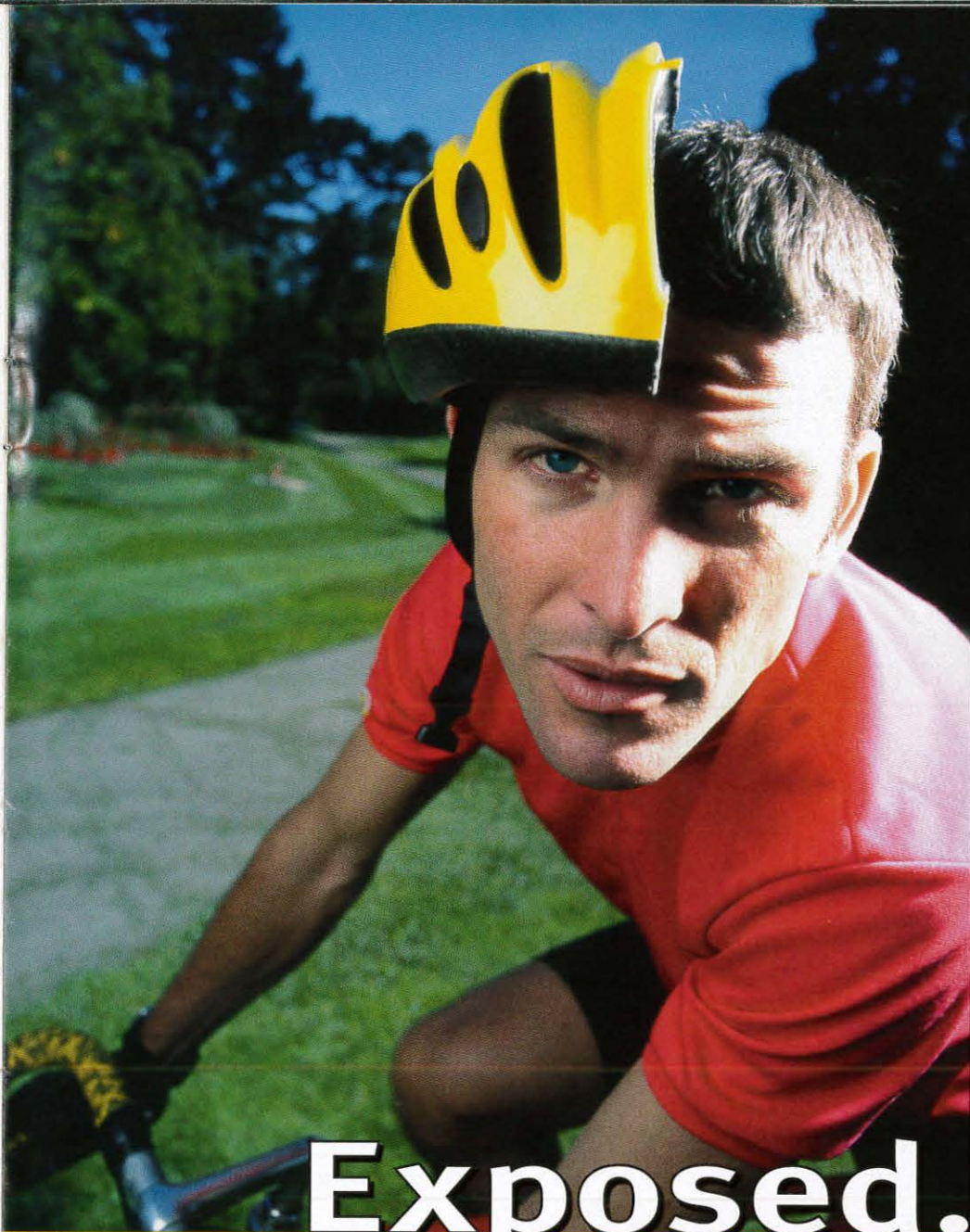

Without fab-wide

IONIZATION

you're still

VULNERABLE

to the hazards of

STATIC CHARGE

Exposed.

Finish the job! You've protected your reticles from ESD and particles in the photolithography area. How about reducing wafer contamination in diffusion areas and wet benches? Ionizing only a few areas of the fab leaves the rest of your process exposed to static charge-related problems. An ESD event can happen anywhere, causing equipment lock-up and product damage.

The more areas you ionize, the better-protected you'll be.

With the threat of equipment downtime and device failures, your potential for static charge-related loss is far greater than the cost of a complete, fab-wide ionization plan. Ionizing your entire facility will provide incremental productivity gains with greater throughput, yield and profits.

Don't leave your process exposed! Call 1-800-367-2452, 510-548-3640 or visit us on the web at www.ion.com.

ION SYSTEMS

From the day we're born,
we go into the world
looking for what we
want with our eyes.



Almost nothing has a bigger impact on product preference than the visual performance of a display. OCLI's image enhancement technology delivers **vivid colors, high contrast** and **crisp resolution** on direct view and projection displays. The difference is an immediately visible improvement that will win over even the most discriminating customers, the moment they see it.

See Us at Display Works, Booth 602

Contact us for more information: www.oci.com

USA (707) 545-6440 (888) 312-0848 EUROPE (49) 6162-93030 JAPAN (81) 3-3225-8974

Circle no. 20

If Displays Are Your Technology...

Don't miss these exciting keynotes:

- Dr. Hsing C. Tuan
President
Unipac Optoelectronics Corp.
- Dr. Kyung Y. Park
Managing Director
PDP Business
Samsung Display Devices
- Mr. Takahisa Hashimoto
Director of Display Technology
IBM Japan
- Dr. Rick Knox
Manager, Portable Technology
Compaq Computer Corp.

Plus...

Over 60 state-of-the-art technical papers on Display Manufacturing

Register at
[www.displayworks.org!](http://www.displayworks.org)

Then Display Works 98 is Your Technology Marketplace!

Display Works 98

Exposition—January 21-22 ■ Conferences and Events—January 19-23

San Jose Convention Center ■ San Jose, California

Display Works 98 brings together all of the leading display technologies in one location. At Display Works 98 you have the opportunity to:

- Learn About the Latest Manufacturing Technologies
- See the Latest Products and Manufacturing Equipment
- Hear the Market Forecasts
- Address the Challenges and Solutions to Manufacturing Electronic Displays

To Exhibit

There's still a small amount of exhibit space left. For information on exhibiting, call SEMI at 650.940.7992

To Attend

Register by December 31 for FREE admission to the exposition and discounts on the Business Conference and Manufacturing Technology Conference. For complete information and registration form, call SEMI at 650.940.6905 or visit www.displayworks.org.

Sponsored by:



display continuum

continued from page 4

the specific conditions that produced the emission surface of the first successful demonstration display.

"Oh, yes. Just one more thing. Since we are planning this as a mainstream display

product, we have enclosed a full analysis of the manufacturing process used to make the display products against which we will be competing. These are the products we plan to "knock out of the saddle" - so to speak - with

our new display this coming spring. Of course, our costs will have to be competitive with their existing process for us to succeed. I'm sure you will take that into consideration when your team tackles the design of the manufacturable prototype and the manufacturing plant layout."

And with that, the message ended. No puffs of smoke or anything. It just stopped. In any case, Jim didn't need to worry. New technology would ensure that no one else would get this communication - smoke or no smoke. And what if they did? Jim wasn't sure that this made any sense to him. It sure wouldn't make sense to anyone else.

Jim decided to wait until he got home from the airport to look over the competitive process analysis. He suspected that even if the competitor's company wasn't named or the exact product described, the information provided would nevertheless be reasonably accurate.

The next morning, he arose early, had his usual bowl of multigrain-plus-everything cereal with the same-as-always quantity of 2 milk poured on top, and read the morning paper, which he always spread in front of him across the table so that the cereal bowl ended up only a few inches from his mouth. (Jim was not only good at designing manufacturing processes, it was obvious that his attention to efficiency carried over into his personal life as well.)

After completing this brief morning ritual, he found the competitive-analysis papers in his briefcase, poured himself a glass of orange juice, and decided to do his pondering out on the deck in back of the house, where he could see the village below and the mountains in the distance. The morning air was already warm presaging the summer day still to come. As he sat and sipped on his orange juice, the information in front of him began to sink in.

The process used by the established display supplier had the following interesting features

- The mechanical parts could all be made by standard machining, punching, or pressing processes and assembled using mechanical jigs for alignment.
- All tolerances were compatible with standard machine-shop tools and fixtures. In fact, there were no dimensions smaller than the size of the red, green, or blue subpixels.
- The production process did not require a clean-room environment. A "neat-and-tidy" room was perfectly adequate.

HOW WOULD YOU MEASURE YOUR DISPLAY REFLECTIONS?

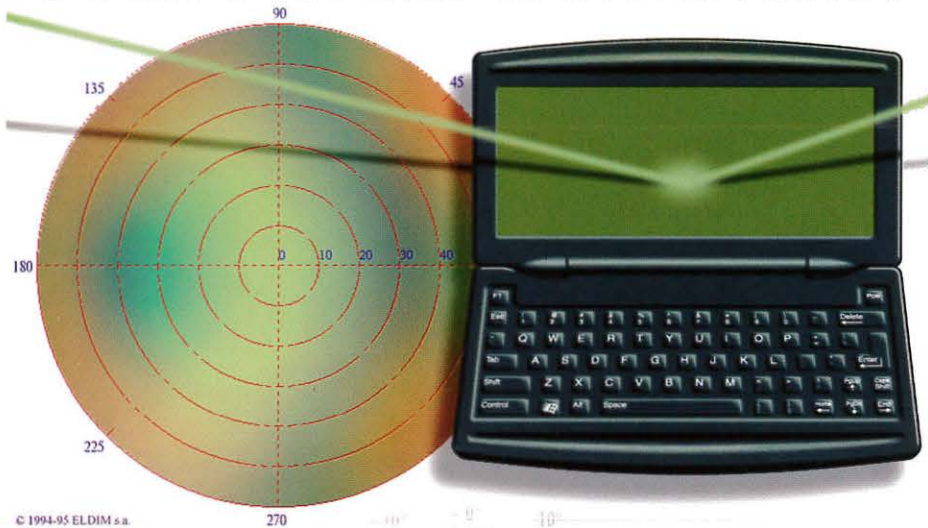

© 1994-95 ELDIM s.a.

EZContrast well known display measurement solution now provides:

- > Diffuse illumination measurements
- > Specular illumination measurements
- > BRDF analysis
- > Automatic angular dynamic adjustment

Over $\pm 80^\circ$ incidence, $0-360^\circ$ azimuth angle while maintaining a measurement speed of less than 1 mn for luminance measurements.

Compatibility with main display characteristics measurement standards (ISO, VESA...).

ELECTRONICS FOR DISPLAYS AND IMAGING DEVICES

4 rue Alfred Kastler 14000 CAEN - France

Phone : + 33 2 31 94 76 00 - Fax : + 33 2 31 47 37 77

E-Mail : eldim@eldim.fr - Internet address : <http://www.eldim.fr>

Circle no. 21



- The production process also had some interesting steps involving the deposition of the three emission surfaces. The deposition was done with an unusual self-aligning technique that could be repeated to pattern the red, green, and blue rectangles but that didn't require the standard step-and-repeat exposure system.
- The emission surface itself, as best he could tell, was applied with some kind of simple spray gun.
- Even though these displays had full HDTV-resolution capability of 1080 × 1900, the signal input was said to be accomplished with only five connections. How could this be? Perhaps they were using an advanced technique with integrated drivers of some type. He checked the information on an earlier lower-resolution product. It also had five connections for the input signal. Somehow, the number of interconnects was independent of the number of pixels being addressed.
- Final processing for these devices was described as a straightforward heating and sealing step. However, what was unique was the claim that these devices actually improved after they were sealed and placed in operation. Product life and reliability were apparently so good that exact numbers weren't even supplied.

As all this information sank in, Jim could begin to see why these displays were priced so competitively. What were his chances of designing a manufacturing process that could accomplish similarly low production costs?

One thing for sure, he would need a cleanroom for at least some of the deposition steps. The rest of the assembly didn't seem all that difficult. He knew how to handle the glass. He knew that the row and column drivers could be patterned for a reasonable cost. The color dot patterning also would be no big deal. But what about that mysterious deposition step? If he could solve that, then perhaps he had a chance of getting his production costs close to those of the competing display products.

As he scanned the raw data supplied to him, he noted that it had taken several hours of operation to create the laboratory-demonstration display. Several hours - and this was only a small 4-inch-diagonal demonstration prototype! How long would it take to do a 12.1-inch or larger display?

Not having a way to answer these questions with the information available to him, he decided to note the issues and move on to another problem that was perplexing him. What about the row and column drivers? If the competition could build a display with five total interconnects what would he need? Certainly, he could use chip-on-glass technology. And the number of drivers could be reduced if he went to custom chips. But as he thought about how to get all the way to 1080 × 1900 resolution, which this product was promising to do, his mind began to shift from detached logical analysis to thoughts of personal well-being. Three thousand connections, all running the length and width of the display. Uniform depositions over large areas with unknown equipment in less than 120 days?

Well, there was "Mission Impossible" - the TV series - and then there was Dr. Jim Phelps in real life. Then, quite suddenly, all the process information supplied to him about the

competing display began to make sense. How could he not have spotted this sooner? In any case, now he knew what all this was about. He knew exactly what the competition was doing, what kind of display they were making, and what their factory looked like.

A feeling of peace and contentment flooded over him. He looked out over the valley. The mountains in the distance looked fresh and green in the morning sun. A few puffy clouds were forming shapes in the sky.

He had made his decision. Later that morning, at his convenience, he would call back with his answer.

Should you have any opinions or decisions of your own to share with me, I can be reached by e-mail at silzars@ibm.net, by phone at 425/557-8850, or by fax at 425/557-8983. The Post Office still works great for some of you letter writers. My personal mountaintop is at 22513 S.E. 47 Place, Issaquah, WA 98029. ■

License PIVOT SOFTWARE®

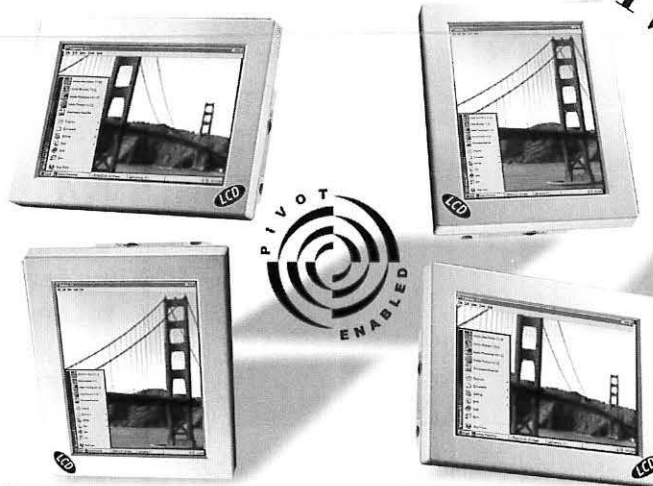

Your customers will see more, and you'll see more customers!

Rotate your LCD display 90, 180 or 270 degrees without quitting the active application.

Compatible with Windows® 3.1x, 95 and NT 4.0; and Mac/OS®

Great for LCD monitors, kiosks, notebooks, all-in-one and tablet computers.

For more information on licensing PIVOT SOFTWARE®, contact:
Mikel Estrin, Vice President of Sales at Portrait Displays, Inc.
Tel: +1 (510) 227-2724 FAX: +1 (510) 227-2705
Email: mestrin @ portrait.com Internet: WWW.PORTRAIT.COM



Circle no. 22

Interface Solutions for flat panels

Speed up development and product realisation time with our high quality flat panel interface controllers for your LCD, Plasma or EL projects. Suitable for small or high volume projects and monitor production.

Analog - Computer

AC series: A range of interface controllers for LCD, Plasma or EL, to connect to analog graphics source. **VGA** (640x480), **SVGA** (800x600), **XGA** (1024x768), **SXGA** (1280x1024).

SV-Series: A combination interface for both computer graphics and video (PAL, NTSC) for LCD & Plasma.

➤ NEC analog panels are also supported.

Bus card - PC

DC series: Includes PCI bus LCD graphics card for providing LCD digital signal output from a PC.



Video - PAL/NTSC

PN series: Advanced multi system video interface for TFT LCD and Plasma panels.

Accessories: A wide variety of support accessories.

Enclosure options:

- Open frame kits: panels & interface controllers in easy to use frames.
- Industrial display systems
- Desktop monitors
- LCD multimedia systems

Digital View

USA: Tel: 408-287 4935, Fax: 408-287 3952
England: Tel: (0)1438-816 600, Fax: (0)1438-816 909
Hong Kong: Tel: 2861 3615, Fax: 2520 2987

Internet: www.digitalview.com
Email: sales@digitalview.com

Circle no. 23

Shake, Rattle & Roll



Engineered for durability, IST 2" miniature CRT displays are designed to withstand severe environments of armored vehicle operation. They feature a high-resolution, high-visibility display in U.S. or European video standards. Plus they meet all applicable military standards.

Let us show you how we can stand up to anything you can shake, rattle or roll our way. Call us at 607-796-4352.



Imaging and Sensing Technology
 300 Westinghouse Circle
 Horseheads, NY 14845-2299
 Fax: 607-796-4579

Circle no. 24

Monitor Shields

A Few Shields Or A Few Thousand — We're Geared For Any Production Peak.

Magnetic shielding — *that's our specialty.*

And we are equipped to handle any

monitor shielding requirement you may have.

It's a matter of applying our experience with our production facilities to

produce your monitor shielding

needs on the most demanding schedule. We can

prove it. Please request our latest catalog.

The Problem Solving Magnetic Shielding Specialists

AD-VANCE MAGNETICS, INC.



P.O. Box 69 • 625 Monroe Street
 Rochester, Indiana 46975
 (219) 223-3158 • FAX (219) 223-2524
 E-Mail: advancemag@aol.com

Web Home Page: <http://www.advancemag.com>

Circle no. 25

Rub & Clean In 1 Machine!



New! Exclusive Innovation from Hornell:
A Combined Rubbing/Dry Cleaning Module for LCD production. Integrating the two processes reduces substrate handling while increasing throughput. Equipment costs and cleanroom space are saved, and overall efficiency improved.

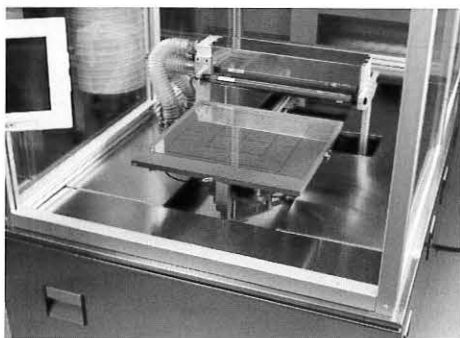

Stand Alone Non-Contact Dry Cleaning Module:
 Eliminates 95% of particles greater than 1 micron. High frequency pressure waves from an ultrasonic head cause particles to vibrate which are then removed by an exhaust airflow.

Continual Innovations in LCD Process Equipment... Exclusively From Hornell Engineering

Hornell's Modular Equipment for LCD Production (MELP) are a series of efficient, high-capacity, high-yield machines for a moderate investment in terms of equipment and cleanroom space. Modular design provides maximum configuration flexibility, ranging from individual, manually-operated machines (for start-up and development), to highly-automated, clustered or in-line arrangements for higher volume runs.

Other MELP Modules:

- Bake-Curing
- Dry Spacer Applicator
- Gasket Sealing
- Align & Assembly
- Breaking
- Filling



Stand Alone Rubbing Module with Rotating Table & Roller: Provides an extremely uniform rubbing action, while prolonging the life of the rub fabric. Ideal for high volume production.

Additional features of the MELP Series include: computer-controlled parameters, touch-screen interfaces, vacuum chuck with automatic alignment, substrate lift mechanism and ionizer bars for ESD control. Call for a personal presentation of Hornell's capabilities.

HORNELL

Automation

Innovative LCD/Optics Equipment & Technologies

North American Headquarters

9337 Ravenna Road, Unit M
 Twinsburg, OH 44087 USA
 Tel: +330-405-1419
 Fax: +330-405-1420
 E-mail: info@hornell.com
 Website: <http://www.hornell.com>

European Headquarters

Tunavägen 281
 S-781 73 Borlänge, SWEDEN
 Tel: +46 243 390 95
 Fax: +46 243 390 55
 E-mail: information@hornell.se
 Website: <http://www.hornell.com>

High Quality Hot Bar Bonding

*Patented Technology
and Process Expertise
from Toddco General*

Advanced Technology

- All Ceramic Hot Bars
- Pulse or Constant Heat
- Improved Quality and Yield

Features Common to All Our Bonders

- Pulsed, constant, or hybrid heat modes
- ACF, heat seal or solder
- All-ceramic hot bars-uniform thermal distribution, stays very flat
- Extra thermocouple ports for process development
- Real-time display of process and control variables
- Automatic recording of bond data
- Custom fixturing available
- Profiles compatible across full line of bonders (17 models)

RSM 2200 Features

- Flex or connector to PCB
- Microprocessor control of pressure, temperature and time
- Multiple, selectable profiles
 - Inspection system
 - Vision image system
 - Crosshair generator
 - Off-line graphical programming software

ACF 6000 Features

- TAB to glass
- TAB to PCB
- Glass to 425mm on edge
- Semi-automatic TAB alignment
- Automatic camera position
- Camera inspection above or below
- Fine pitch <70 micron
- Graphical user interface
- Teach mode programming

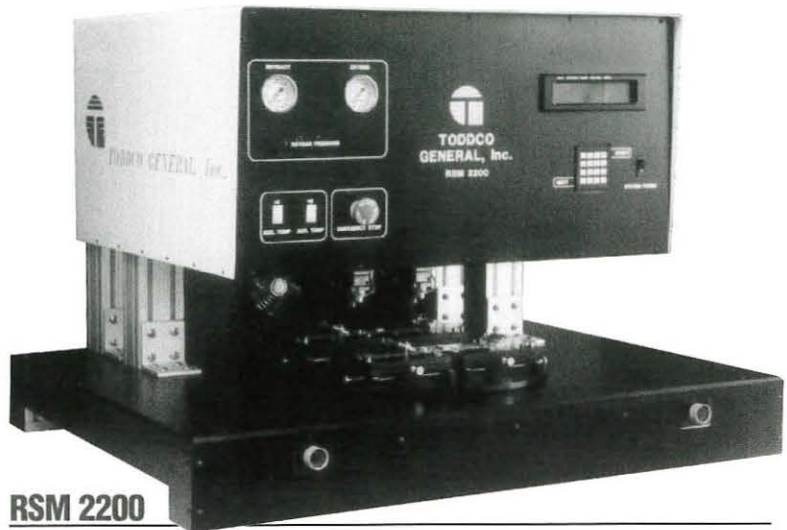

RSM 2200

Two Head Bonder with Rotary Table

ACF bond or solder two products while loading and unloading two.



ACF 6000

Fine Pitch Anisotropic Film Bonder

Automated functions reduce process variation, improve quality.

*Turn Key Systems
Available*

*Call today to get more information.
Ask for your FREE short form catalogue.*



TODDCO GENERAL, Inc.
7888 Silverton Ave., Suite A
San Diego, CA 92126, USA
(619) 549-9229 • (619) 549-2162 FAX
Email: toddco@toddco.com
<http://www.toddco.com>

Gerome Manufacturing Company, Inc.

Introduces a New Innovation in Vinyl-clad
Product Design and Manufacturing

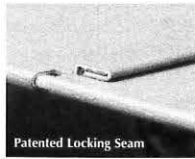
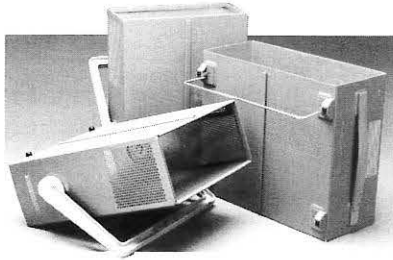

Gerome Manufacturing Company has a patented technique to provide instrumentation enclosures with two useful and unique features:

- A continuous metallic, conductive and shielding path around the instrument, requiring no welding or riveting.
- An exterior of attractive, tough, insulating vinyl, requiring no painting.

We feature Arvinyl Laminated Materials in the products we produce. These products come in a variety of colors and textures. Custom colors can also be produced.*

Vinyl can be laminated to a variety of base metals such as carbon steel, electrogalvanized steel, stainless steel, hot-dipped galvanized steel, and alloys of aluminum.

Gerome's engineering department can assist you in the design of your product, from new lines to changing existing painted products to a vinyl-clad material.

We have performed cost studies for manufacturing both painted and vinyl products, and have found that it is more cost effective to produce vinyl-clad products than painted products, and at the same time produce a much higher quality product with vinyl. Call for details or a sample.

*Custom colors require a minimum quantity order. Call for specific details.



Gerome Manufacturing Company, Inc.

403 N. Main Street • P.O. Box 747 Oliver Road • P.O. Box 1089
Newberg, OR 97132 Uniontown, PA 15401
Phone: (503) 538-8356 Phone: (412) 438-8544
Fax: (503) 538-1090 Fax: (412) 437-5608
E-mail: gerome@teleport.com

Circle no. 28

Model 875 Video Pattern Generator



**New. High Performance.
Small. Affordable.**

Lightweight and portable, the new Video Instruments Model 875 practically fits in the palm of your hand. Yet the number of patterns and rates that can be downloaded from your P.C. to the unit is virtually unlimited. Talk about versatile!

Call 1-800-962-8905
and we'll fax you the specs.

V.I. VIDEO INSTRUMENTS

2155 Bellbrook Avenue • Xenia, OH 45385-4043
Phone: 937-376-4361 • Fax: 937-376-2802

Circle no. 29

REAL-TIME VIDEO WINDOWS ON COMPUTERS

SIMULATION C³I SURVEILLANCE
INTERACTIVE VIDEO DISC TRAINING
ROBOTICS INDUSTRIAL CONTROL
VIDEO TELECONFERENCING



SUPERVIEW™ OFFERS

- Up to **6** real-time video windows
- Windows scalable to full screen
- Optional inputs for VGA, FLIR, radar and medical imagers
- Text and graphics overlays on video
- Compatibility with all high resolution graphics controllers

SuperView video windowing systems are available in standalone and 6U VME configurations.



RGB SPECTRUM®
A visual communications company™

950 Marina Village Parkway Alameda, CA 94501
Tel: (510) 814-7000 Fax: (510) 814-7026

Circle no. 30

sustaining members

Acer Peripherals
 Ad-Vance Magnetics, Inc.
 Advance Reproductions Corp.
 AlliedSignal, Inc./
 MicroOptic Devices
 Arconium
 Brewer Science, Inc.
 Brimar Ltd.
 Canon, Inc.
 Capetronic Computer USA (HK),
 Inc.
 Celco
 Cherry Electrical Products
 Chunghwa Picture Tubes, Ltd.
 Clinton Electronics Corp.
 Corning Inc.
 Corning Japan K.K.
 Crystaloid LCDs
 Dale Electronics, Inc.
 David Sarnoff Research Center
 Diagnostic/Retrieval Systems, Inc.
 Display Inspection Systems
 Display Laboratories
 DNP Denmark
 dpiX, A Xerox Company
 Electronic Designs, Inc.
 Electro-Plasma, Inc.
 Endicott Research Group, Inc.
 Epson America
 FED Corp.
 F-P Electronics
 Flat Panel Display Co. (FPD) B.V.
 Futaba Corp.
 General Vacuum
 Gerome Manufacturing
 GE Plastics Japan Ltd.
 Graseby Optronics
 Hewlett-Packard Co.
 Hitachi, Ltd.
 F. Hoffmann-La Roche
 Honeywell, Inc.
 Hoya Corporation USA
 Hughes Lexington
 Hyundai Electronics America
 IBM Corp.
 Imaging & Sensing Technology
 Incom, Inc.
 Industrial Electronic Engineers, Inc.
 Industrial Technology Research
 Institute
 In Focus Systems, Inc.
 Infodex, Inc.
 Innotec Group, Inc.
 Interface Products, Inc.
 Interserv Corp.
 Interstate Electronics Corp.
 ISE Electronics Corp.
 Kent Display Systems
 Lam Research
 LG Electronics, Inc.
 Libbey-Owens-Ford Co.
 Linfinity Microelectronics
 Litton Systems Canada Ltd. (2)
 Loral Librascope

Man & Machine, Inc.
 Micron Display Technology, Inc.
 Micronic Laser Systems AB
 Microvision Corp.
 Minolta Corp.
 Minolta Hong Kong Ltd.
 Mitsubishi Electronics America
 Motif, Inc.
 Motorola FPD Division
 MRS Technology, Inc.
 NEC Corp., Japan
 Nippon Seiki Co., Ltd.
 Norden Systems Westinghouse
 OIS Optical Imaging Systems, Inc.
 OKI Electric Industry Co., Ltd.
 Optical Coating Lab., Inc.
 Phosphor Technology Ltd.
 Photonics Systems, Inc.
 Photo Research
 Photonics, Inc.
 Pilkington Micronics Ltd.
 Planar Systems, Inc.
 Plasmaco, Inc.
 Polytronix, Inc.
 Progressive Systems Technology,
 Inc.
 Q.C. Optics, Inc.
 Quantum Data Inc.
 Raytheon Company
 Regisbrook Group, Ltd.
 Rockwell International
 ROLIC Liquid Crystals R&D Co.
 Schott Corp.
 Semiconductor Systems, Inc.
 Sharp Corp. - Japan
 SI Diamond Technology
 Sony Corp. of America
 Sony Corp./Corporate Research
 Labs
 Standish Industries, Inc.
 Stanford Resources, Inc.
 Supertex, Inc.
 Syntronic Instruments, Inc.
 Tamarack Scientific Co., Inc.
 TDK Corp.
 TEAM Systems
 Techneglas, Inc.
 Teledyne Electronic Technologies
 Terapixel, Inc.
 Thomas Electronics, Inc.
 Thomson Components and Tubes
 Corp.
 Toshiba America
 Ultra Electronics
 ULVAC Technologies, Inc.
 Universal Display Corp.
 Viratec Thin Films Inc.
 Wande, Inc.
 The Westaim Corp.
 Westar Corp.
 WinTron
 XMR, Inc.

index to advertisers

Ad-Vance Magnetics.....	44	Mitsubishi.....	10,11
Abbie Greg, Inc.....	38	NEC Technologies.....	6,7
Digital View.....	44	N-Vision.....	38
Display Works.....	41	OCLI.....	40
Eaton.....	9	Optrex.....	C3
ELDIM.....	42	Photo Research.....	C4
Ergotron.....	5	Portrait Displays.....	43
H. L. Funk Consulting.....	36	RGB Spectrum.....	47
Gerome Manufacturing.....	38,47	Samsung Semiconductor.....	24,25
Hornell Automation.....	45	Spire Corp.....	37
Ion Systems.....	39	TEAM Systems.....	3,23
Instrument Systems.....	19	Three-Five Systems.....	C2
IST.....	44	Todoco General.....	46
Kent Displays.....	8	Westar Corp.....	15
Klein Instruments.....	15	ViewTEK.....	5
The Micromanipulator Co.....	37	Video Instruments.....	47
Microvision.....	31		

Business and Editorial Offices

Palisades Institute for Research
 Services, Inc.
 201 Varick Street, Suite 1006
 New York, NY 10014
 Jay Morreale, Managing Editor
 212/620-3371 Fax: 212/620-3379

Sales Office

Palisades Institute for Research
 Services, Inc.
 201 Varick Street, Suite 1006
 New York, NY 10014
 Erika Targum, Director of Sales
 212/620-3375 Fax: 212/620-3379



OPTREX
AMERICA, INC.



Dot Matrix
Character Module



Color Graphics
LCD Module

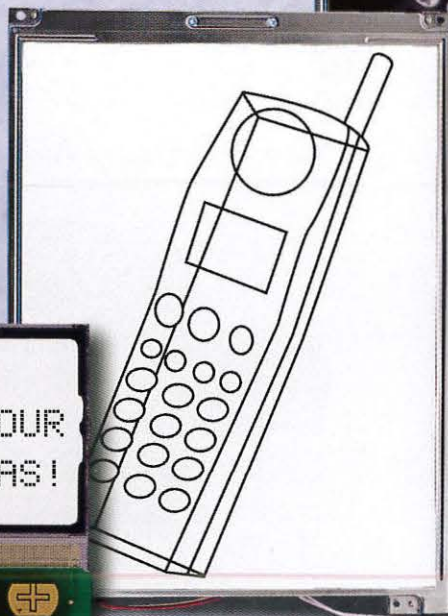

Monochrome
Graphics LCD
Module

OPTREX
DISPLAYS YOUR
BRIGHT IDEAS!

Custom
LCD Module

We Can Put Any Bright Idea On Display.

Whatever your LCD needs – standard or custom – Optrex can offer an effective, cost-efficient solution.

For over 30 years, manufacturers have relied upon Optrex for technologically-advanced character, monochrome, color and custom LCD configurations. Founded as a joint venture between Asahi Glass Co. LTD. and Mitsubishi Electric Corp., Optrex provides technical design and support through our own sales organization, and through more than 100 sales and distribution offices worldwide.

For more information call Optrex, or see your electronics distributor today.



OPTREX
AMERICA, INC.

Circle no. 31

44160 Plymouth Oaks Blvd. • Plymouth, MI 48170 • (313) 416-8500 • FAX: (313) 416-8520

©1997, Optrex America Inc. All Rights Reserved.

WORK JUST GOT EASIER

Announcing a New Era in Innovation from the Experts at Photo Research



You needed better accuracy. You wanted faster measurements. You asked for more robust software. Now, you've got it. Everything to make your workload lighter. Your workday easier. Innovative systems and software that do more, in less time, at higher reliability than ever before. Power up your R&D and QC testing with these performance boosts:

PR-705

Advanced High Precision Spectroradiometer

- ✓ 10x more sensitive
- ✓ stand-alone operation
- ✓ six apertures for maximum versatility

PR-9000

Complete FPD Inspection System

- ✓ ISO & VESA compatible testing
- ✓ custom solutions tailored to your needs
- ✓ incorporates industry standard instruments and positioners

PR-880A

Fully Automated Photometer for FPD/CRT Testing

- ✓ 20x faster
- ✓ internal source assures highest accuracy
- ✓ ideal for reliable luminance and contrast ratio measurements

All our products come with flexible, application-oriented software such as SpectraWin, PanelWin and VideoWin.

Simplify your work with total solutions from the leader in precision light and color measurement systems. Call today or email us at sales@photoresearch.com

Phone: 818.341.5151



PHOTO RESEARCH[®] INC.

The Experts in Light and Color

9330 DeSoto Avenue, Chatsworth, California 91311-4926 • Fax: 818.341.7070 • <http://www.photoresearch.com>
ID10/97

Circle no. 32