

DISPLAY WEEK 2014 PREVIEW / BACKPLANES ISSUE

**SID**  
SOCIETY FOR INFORMATION DISPLAY

# Information DISPLAY

Official Monthly Publication of the Society for Information Display • [www.informationdisplay.org](http://www.informationdisplay.org)

Mar./Apr. 2014  
Vol. 30, No. 2



## Great Innovations SID's 2014 Honorees

**REFLECTIVE PERFORMANCE  
IN CURVED OLED TVs**

**PRINTING ELECTRONICS  
ON PAPER**

**CHALLENGES FACING  
OLED LIGHTING**

**LTFS VS. IGZO  
BACKPLANES**

**Plus:  
DISPLAY DEVELOPMENT  
AT CES 2014**

**FIRST LOOK AT  
DISPLAY WEEK 2014**

**LA CHAPTER  
CONFERENCE REVIEW**

**WILEY**



# Your Customers' Experience Should Be Nothing Less Than Radiant

Ensure Display Quality with Automated Visual Inspection Solutions from Radiant Zemax



- Automated Visual Inspection Systems for flat panel displays ensure that each display delivers the perfect experience your customers expect.
- Reduce returns and protect brand integrity with accuracy and consistency that is superior to human inspection.
- Customize pass/fail criteria to detect defects including line and pixel defects, light leakage, non-uniformity, mura defects and more.
- Integrated solutions from Radiant Zemax bring repeatability, flexibility and high throughput to the most demanding production environments.

Learn more at [www.radiantzemax.com/FPDtesting](http://www.radiantzemax.com/FPDtesting)



**Radiant Zemax**  
SEE THE DIFFERENCE

## contents

**ON THE COVER:** This year's winners of the Society for Information Display's Honors and Awards include **Dr. Katsumi Kondo**, who will receive the Karl Ferdinand Braun Prize; **Dr. Dirk J. Broer**, who will receive the Jan Rajchman Prize; **Candice Brown Elliott**, who will be awarded the Otto Schade Prize; **Dr. Han-Ping Shieh**, who will be awarded the Slottow-Owaki Prize; and **Jenny Bach**, who will receive the Lewis & Beatrice Winner Award.



### In the Next Issue of Information Display

#### Wearable Displays and Display Week 2014 Issue

- Display Industry Awards
- Products on Display
- Displays on Textiles
- Near-to-Eye Displays
- TADF OLED Emitters
- Samsung's Curved LCD TV

INFORMATION DISPLAY (ISSN 0362-0972) is published 6 times a year for the Society for Information Display by Palisades Convention Management, 411 Lafayette Street, 2nd Floor, New York, NY 10003; William Klein, President and CEO. EDITORIAL AND BUSINESS OFFICES: Jay Morreale, Editor-in-Chief, Palisades Convention Management, 411 Lafayette Street, 2nd Floor, New York, NY 10003; telephone 212/460-9700. Send manuscripts to the attention of the Editor, *ID*, SID HEADQUARTERS, for correspondence on subscriptions and membership: Society for Information Display, 1475 S. Bascom Ave., Ste. 114, Campbell, CA 95008; telephone 408/879-3901, fax -3833. SUBSCRIPTIONS: *Information Display* is distributed without charge to those qualified and to SID members as a benefit of membership (annual dues \$100.00). Subscriptions to others: U.S. & Canada: \$75.00 one year, \$7.50 single copy; elsewhere: \$100.00 one year, \$7.50 single copy. PRINTED by Wiley & Sons. PERMISSIONS: Abstracting is permitted with credit to the source. Libraries are permitted to photocopy beyond the limits of the U.S. copyright law for private use of patrons, providing a fee of \$2.00 per article is paid to the Copyright Clearance Center, 21 Congress Street, Salem, MA 01970 (reference serial code 0362-0972/14/\$1.00 + \$0.00). Instructors are permitted to photocopy isolated articles for noncommercial classroom use without fee. This permission does not apply to any special reports or lists published in this magazine. For other copying, reprint or republication permission, write to Society for Information Display, 1475 S. Bascom Ave., Ste. 114, Campbell, CA 95008. Copyright © 2014 Society for Information Display. All rights reserved.

- 2 Editorial: California Dreaming**  
■ By Stephen P. Atwood
- 3 Industry News: Qualcomm Halts 4K Chip Production**  
■ By Jenny Donelan
- 4 Guest Editorial: A Short History of Backplane Technology**  
■ By Adi Abileah
- 6 SID's Best and Brightest: 2014 SID Honors and Awards**  
This year's winners of the Society for Information Display's Honors and Awards include **Dr. Katsumi Kondo**, who will receive the Karl Ferdinand Braun Prize; **Dr. Dirk J. Broer**, who will receive the Jan Rajchman Prize; **Candice Brown Elliott**, who will be awarded the Otto Schade Prize; **Dr. Han-Ping Shieh**, who will be awarded the Slottow-Owaki Prize; and **Jenny Bach**, who will receive the Lewis & Beatrice Winner Award.  
■ By Jenny Donelan
- 12 Frontline Technology: Reflection Performance in Curved OLED TVs**  
One of the creators of the IDMS (Information Display Measurements Standard) takes the measure of the latest large, curved OLED TVs. In this second article in a series, he looks at reflection performance and makes a discovery that may necessitate a revision to the reflection measurement procedure in the IDMS standard.  
■ By Edward F. Kelley
- 20 Frontline Technology: The Future Is Paper Based**  
Paper may be the key to an entirely new class of inexpensive flexible electronics, including displays.  
■ By Rodrigo Martins, Luis Pereira, and Elvira Fortunato
- 26 Frontline Technology: Flat-Panel-Display Backplanes: LTPS or IGZO for AMLCDs or AMOLED Displays?**  
After more than 20 years as the flat-panel-display backplane TFT material of choice, a-Si:H is running out of steam. The two contending replacement options are LTPS and IGZO. Which is better and how does this material choice impact the race between AMLCD and AMOLED-display front-plane technologies?  
■ By John F. Wager
- 30 Symposium Preview: Everything You Need to Know About Displays (in Four Days)**  
The annual technical symposium at Display Week features a mix of breaking news, developments, and predictions from hundreds of key companies and academic institutions that can be found nowhere else.  
■ By Jenny Donelan
- 36 Display Marketplace: OLED Lighting: The Differentiation Challenge**  
In order for OLED lighting to catch up to LED lighting, cost and performance gaps will have to narrow. In the interim, successful lighting companies will capitalize on OLED lighting's unique design attributes.  
■ By Khasha Ghaffarzadeh
- 40 Show Review: CES 2014 Display Developments**  
This will go down as the year that both UHD and curved displays found commercial traction. It all began with a bang at the annual International Consumer Electronics Show in Las Vegas. And there was even more to see at CES in January – including cars.  
■ By Steve Sechrist
- 46 SID News: SID LA Chapter's One-Day Conference on Technologies for Advanced Television**  
■ By Ken Werner
- 52 Sustaining Members**
- 52 Index to Advertisers**

For Industry News, New Products, Current and Forthcoming Articles,  
see [www.informationdisplay.org](http://www.informationdisplay.org)



## California Dreaming

by Stephen P. Atwood

*"When the wintry winds start blowing and the snow is starting in the fall  
Then my eyes went westward knowing, that's the place that I love best of all"*

Those are the opening lines of a famous song you probably do not recognize because in most cases it's the chorus that gets used on TV and in the movies. But, if you look it up you'll realize it's the opening to the familiar refrain:

"California here I come, right back where I started from..." originally sung by Al Jolson (1924, Jolson, De Sylva & Meyer) but performed by everyone from the cast of *I Love Lucy* to actors in old western movies and Broadway musicals, and even by animated characters in the Bugs Bunny cartoons.

This came to mind as I sat down to write this month's editorial to introduce our March/April issue, which highlights, among other things, the upcoming annual Display Week event in San Diego, California. Coincidentally, it really is snowing lightly here in late February as I write this and the thought of being in southern California in a few months after this long winter is very appealing!

It's been a long time since I've been to San Diego, which is a beautiful city that forms a delightful oasis between the California desert and the Pacific Ocean. Early in my career, I had the privilege of visiting the Sony television assembly plant where they had just begun to manufacture Trinitron television tubes and TV sets in the U.S. It was a big deal back then, both the technology and the migration of that technology to the U.S., and it was in a wonderful new facility just north of San Diego. We dreamed of flat-screen TVs that might hang on the wall but hardly imagined the eventual total domination of LCD technology. Now as I look back I really am amazed by how much the field of displays has changed and evolved since that time – and it still seems like yesterday.

Our cover story this month celebrates the SID 2014 Honors and Awards, recognizing the many achievements of those who have invested so much of their careers to furthering the field of displays. And, as you look through this year's group of recipients, you will notice that practically all of them are being recognized for their contributions to LCD or active-matrix technology – nary a mention of CRTs. As I have written previously, while the honors are being bestowed on these leaders of the display industry, the real honor goes to those of us who have had the privilege of knowing them, working with them, learning from them, and using their innovations to build better products that enrich people's lives.

Each year we do our best to capture their achievements in the biographies and citations thoughtfully compiled by our own Jenny Donelan. But nothing we write can come close to documenting the lifetime's worth of ideas, challenges, setbacks, inspirations, and successes that these individuals have weathered on behalf of our industry. Great innovation never really happens overnight and so much of the technology that we take for granted today was built layer upon layer, with each new advancement leveraging the achievements of the previous for its support. I'm sure, as you read this story, you will come away with something from the award recipients' lives and work you can relate to. Take the time to reach out to them and say "Congratulations and Thank You" for everything they have achieved.

We also have a strong offering of technical articles for you this month, covering notable topics in OLEDs, backplanes, and paper electronics. The subject of paper

(continued on page 48)

## Information DISPLAY

**Executive Editor:** Stephen P. Atwood  
617/306-9729, satwood@azonix.com

**Editor-in-Chief:** Jay Morreale  
212/460-9700, jmorreale@pcm411.com

**Managing Editor:** Jenny Donelan  
603/924-9628, jdonelan@pcm411.com

**Advertising Sales Manager:**  
Joseph Tomaszewski  
201-748-8895, jtomaszewski@wiley.com

**Advertising Sales Representative:**  
Roland Espinosa  
201-748-6819, respinosa@wiley.com

### Editorial Advisory Board

Stephen P. Atwood, Chair  
*Azonix Corp., U.S.A.*

Helge Seetzen  
*TandemLaunch Technologies, Westmont, Quebec,  
Canada*

Allan Kmetz  
*Consultant, U.S.A.*

Larry Weber  
*Consultant, U.S.A.*

### Guest Editors

**Flexible Technology and e-Paper**  
*Jason Heikenfeld, University of Cincinnati*

**Novel Materials**  
*Ion Bitu, Qualcomm MEMS Technologies*

**OLEDs**  
*Sven Murano, Novaled AG*

**Backplanes**  
*Adi Abileah, Consultant*

**Wearable Displays**  
*Xiao-Yang Huang, Ebulent Technologies*

**Interactivity/Touch**  
*Bob Senior, Canatu*

**Tablets**  
*Jennifer Gille, Qualcomm MEMS Technologies*

**Manufacturing**  
*Elliott Schlamm, Elliott Schlamm Associates*

**3D/Holography**  
*Nikhil Balram, Ricoh Innovations*

### Contributing Editors

Alfred Poor, *Consultant*  
Steve Sechrist, *Consultant*  
Paul Semenza, *NPD DisplaySearch*  
Jason Heikenfeld, *University of Cincinnati*

The opinions expressed in editorials, columns, and feature articles do not necessarily reflect the opinions of the Executive Editor or Publisher of *Information Display Magazine*, nor do they necessarily reflect the position of the Society for Information Display.

## Qualcomm Halts 4K Chip Production

CES 2014 featured a large number of developments from the 4K landscape, and one of the most prominent was Qualcomm's new system-on-a-chip for smart TVs, the 4K-ready Snapdragon 802 (Fig. 1). The Snapdragon 802 was a 1.8-GHz quad-core processor with a 4K-capable Adreno 330 graphics processor and integrated Wi-Fi. It was scheduled to start shipping in the second half of 2014, but less than 6 weeks after its introduction at CES in January, Qualcomm announced that it would not be producing the chip after all.

According to Qualcomm, the demand for smart TVs is not yet strong enough to warrant building the chips. In a press release<sup>1</sup> the company said: "Qualcomm Technologies, Inc., has decided not to commercialize the recently announced Snapdragon 802 processor as the overall demand for processors uniquely designed for smart TVs has proven to be smaller than anticipated. This decision is specific to the Snapdragon 802 processor and does not affect other products we are currently shipping in this segment."

Many online bloggers point to the slow advent of smart TV as a legitimate reason for the company's decision, but question how development proceeded as far as it did until now. Qualcomm did not comment further after the announcement.

<sup>1</sup><http://www.qualcomm.com/media/blog/2014/02/14/snapdragon-802-processor-update>

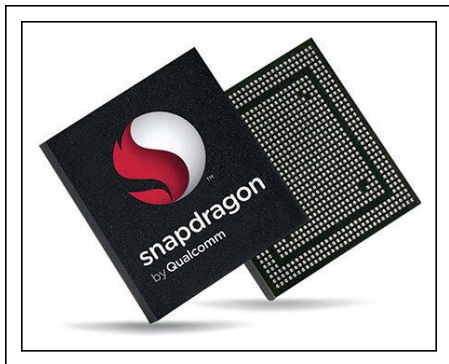

**Fig. 1:** Development of Qualcomm's Snapdragon 802 4K-ready chip stopped in February 2014, but the company's other Snapdragon processors are still in production.

## Smartphone Trends

The recent Mobile World Congress (February 2014 in Barcelona) prompted a flurry of announcements from smartphone manufacturers. Here are some updates on new and upcoming devices:

**LG Electronics** has three new models: the LG G Pro 2, the LG G2 mini, and the LG L Series III. The G Pro 2 has an impressively large 5.9-in. full-HD IPS display and an enhanced 13MP camera. The LG G2 mini is LG's first "compact" smartphone and comes with a 4.7-in. IPS display. The new L Series III is the company's budget line and is aimed especially at emerging markets. Series III models are available in 3.5-, 4.5-, and 4.7-in. sizes.

Russian smartphone maker **Yota Devices** has announced a new version of its two-sided Yotaphone. The first generation had a touch-screen LCD on one side and an e-paper display on the other. The phone was designed so that users could save battery power by employing the e-paper side for simple tasks such as checking dates, viewing texts, etc. The new Yotaphone has a 4.7-in. touch e-paper screen so users can now open and respond to notifications, not just read them. The LCD side has been replaced by an AMOLED version (Fig. 2).

**Samsung** recently introduced the Galaxy S5, which comes with a 5.1-in. display, a fingerprint scanner, a heart-rate sensor, and the Android 4.4 KitKat OS. It is run by the Snapdragon 801 processor and backed by 2 GB of RAM. Continuing the tradition of powerful cameras in the Galaxy phones, the S5 has a 16MP version.

Finnish smartphone maker **Nokia** has come out with the Nokia XL, a great-looking and extremely affordable 5-in. model costing around €109. It features a customized version of Google's Android OS (streamlined so as to work more efficiently with the Snapdragon 1-GHz dual-core processor), and a 4MP camera.



**Fig. 2:** The two-sided Yotaphone features a monochrome touch e-paper display on one side and a colorful AMOLED display on the other.

## Tactus Announces Series B Funding

Tactus Technology, Inc., a developer of on-demand tactile surfaces, recently announced that it has closed the first portion of a Series B funding round with new investors from Asia. Tactus designs electronic surfaces that use microfluidics to transform a flat touch-screen interface to a physical three-dimensional one – with raised keyboard buttons, for example. This technology was the winner of SID's first Best Prototype Award for its demonstration in the Innovation Zone (I-Zone) at Display Week 2012.

The new investors include Ryoyo Electro Corp. (Tokyo), one of Japan's leading electronics suppliers and other financial entities in Asia. They join Thomvest Ventures and other initial corporate investors who have reinvested in the Series B funding. As part of the Series B round, Ryoyo will become the exclusive sales partner and distributor for Tactus components and display technology subsystems in Japan. The Series B round is expected to raise between \$10 and \$15 million when completed.

Tactus reports that products utilizing its "disappearing keyboard" technology will be

(continued on page 49)



## A Short History of Backplane Technology

by Adi Abileah

Backplanes for LCDs have experienced a long and very crucial technological evolution in the last 20-plus years. Before the adoption of active matrix (AM), the direct driving of LCD pixels or segments was the standard driving mode for all LCD devices. Today, it is still used for some low-information-content displays, typically those with alphanumeric characters. However, device developers were driven to switch to AM addressing when information-content requirements went up. Along with the need for an AM came the need for a switching device located inside the pixel matrix on the backplane of the display. Such a device allowed for a full image to be displayed and almost eliminated the partial driving of unselected pixels.

In the late 1980s, amorphous silicon (a-Si) became the overwhelmingly popular choice for switching devices. This was a derivative of a-Si development for solar cells. In the early 1990s, several pioneers in a-Si TFTs for LCDs, such as OIS, IBM, NEC, Sharp, and a few others, demonstrated products based on a-Si. A contender to a-Si at that time was CdSe (cadmium selenide), promoted by the late Dr. Peter Brody. However, the a-Si process was proven to have better manufacturability. Another debate in those days was whether to use back-to back diodes or a transistor as a switching device. The industry settled on the a-Si thin-film transistor (TFT).

Beginning in the early 90s, a-Si TFT was used for all LCD manufacturing. Its process resulted in very high yields and was expandable to large glass substrates. The limitations of a-Si are relatively low mobility and some instability of the current-voltage curve. For an LCD, the instability is not critical while the device is used as a switching device.

Now, enter OLED technology for large-area displays. As for LCDs, a backplane and AM-addressing architecture are also used to achieve high information content. Unlike LCDs, the OLED pixel requires a continuous supply of electrical current to emit light, and therefore the switching devices must do much more than simply select and store a voltage between refresh cycles. Consequently, the driving circuits for OLED pixels are more complex and require several switching components in each cell as well as much higher mobility and stability. It has been widely reported that a-Si is not a suitable solution in this case. As a result, a new and more urgent focus has been placed on developing advanced structures from several different materials, including crystalline-silicon structures or polysilicon. This process is more complex and requires the annealing of the silicon layer on the glass. Sometimes this is done with localized exposure of an excimer (UV) laser. As of now, several manufacturing plants are dedicated to the polysilicon process. Almost all are using the low-temperature process with laser annealing and several processes are in commercial use today.

However, there are other areas of research, including oxide semiconductors, that have shown a great deal of promise and similar commercial adoption. In this issue, we examine this new technology, more specifically indium gallium zinc oxide (IGZO). Work on IGZO started almost two decades ago in Japan and in the labs of Professor John Wager at Oregon State University. The technology is now becoming mature and is being integrated into manufacturing. We are fortunate to have an article by John Wager in this issue of *Information Display*, explaining the technology and comparing it to a-Si [hydrogenated a-Si (a-Si:H)] and polysilicon [or low-temperature poly-

(continued on page 49)

### SID EXECUTIVE COMMITTEE

President: B. Berkeley  
President-Elect: A. Ghosh  
Regional VP, Americas: D. Eccles  
Regional VP, Asia: B. Wang  
Regional VP, Europe: P. Kathirgamanathan  
Treasurer: Y. S. Kim  
Secretary: H. Seetzen  
Past President: M. Anandan

### DIRECTORS

Bangalore: T. Ruckmangathen  
Bay Area: J. Pollack  
Beijing: X. Yan  
Belarus: A. Smirnov  
Canada: T. C. Schmidt  
Dayton: D. G. Hopper  
Delaware Valley: J. W. Parker III  
Detroit: J. Kanicki  
France: J-P. Parneix  
Hong Kong: H. S. Kwok  
India: Y. Mohapatra  
Israel: G. Golan  
Japan: K. Kondoh  
Korea: K.-W. Whang  
Latin America: A. Mamma  
Los Angeles: L. Tannas  
Mid-Atlantic: J. Kymissis  
Mid-Europe: H. De Smet  
New England: S. Atwood  
Pacific Northwest: A. Abileah  
Russia: V. Belyaev  
Singapore: T. Wong  
Southwest: S. O'Rourke  
Taipei: J. Chen  
Texas: Z. Yaniv  
U.K. & Ireland: S. Day  
Ukraine: V. Sergan  
Upper Mid-West: B. Bahadur

### COMMITTEE CHAIRS

Academic: P. Bos  
Archives: R. Donofrio  
Audit: S. O'Rourke  
Bylaws: T. Lowe  
Chapter Formation - Europe: H. De Smet  
Conventions: P. Drzaic  
Conventions - Europe: I. Sage  
Definitions & Standards: T. Fiske  
Display Industry Awards: W. Chen  
Honors & Awards: F. Luo  
I-Zone: J. Kanicki  
Investment: Y. S. Kim  
Long-Range Planning: A. Ghosh  
Membership: H.-S. Kwok  
Membership Vice-Chair, Social Media: H. Atkuri  
Nominating: A. Anandan  
Publications: H. Seetzen  
Senior Member Grade: A. Ghosh  
Web Site: H. Seetzen  
Web Activities: L. Palmateer

### CHAPTER CHAIRS

Bangalore: S. Sambadam  
Bay Area: R. Rao  
Beijing: N. Xu  
Belarus: V. A. Vyssotski  
Canada: A. Kitai  
Dayton: J. Luu  
Delaware Valley: J. Blake  
Detroit: J. Byrd  
France: L. Vignau  
Hong Kong: M. Wong  
India: S. Kaura  
Israel: I. Ben David  
Japan: K. Kondo  
Korea: S. T. Shin  
Latin America: V. Mamma  
Los Angeles: L. Iboshi  
Mid-Atlantic: G. Melnik  
Mid-Europe: H. J. Lemp  
New England: J. Gandhi  
Pacific Northwest: K. Yugawa  
Russia: M. Sychov  
Singapore/Malaysia: C. C. Chao  
Southwest: M. Strnad  
Taipei: C. C. Wu  
Texas: R. Fink  
U.K. & Ireland: M. Jones  
Ukraine: V. Sorokin  
Upper Mid-West: P. Downen

### SOCIETY FOR INFORMATION DISPLAY

1475 S. Bascom Ave., Ste. 114, Campbell, CA 95008  
408/879-3901 e-mail: office@sid.org  
http://www.sid.org

# SINTERING?

Turn **up** the energy. Turn **down** the heat.

Only pulsed light provides the high peak-power pulses necessary to sinter conductive inks while keeping temperatures cool enough to avoid damage to heat-sensitive substrates – the key challenge when printing on paper and plastic. When you need to turn up the energy and turn down the heat, turn to the leaders in pulsed light.

Let's find a solution to your sintering challenges.



Go to [www.xenoncorp.com/sinter1](http://www.xenoncorp.com/sinter1) to learn more about Xenon's sintering solutions.

**XENON**  
Leaders in pulsed light

**XENON Corporation**  
37 Upton Drive  
Wilmington, MA 01887 U.S.A.  
[www.xenoncorp.com](http://www.xenoncorp.com)  
1-800-936-6695

See Us at Display Week 2014, Booth #1827

*Your company and Information Display*

See how  
powerful  
the right  
partnership  
can be.

Information  
**DISPLAY**

**SID**  
SOCIETY FOR INFORMATION DISPLAY

**WILEY**

Contact: Roland Espinosa: [respinosa@wiley.com](mailto:respinosa@wiley.com) • 201-748-6819

## 2014 SID Honors and Awards

*This year's winners of the Society for Information Display's Honors and Awards include **Dr. Katsumi Kondo**, who will receive the Karl Ferdinand Braun Prize for his contributions to the development of in-plane-switching (IPS) TFT-LCD technology; **Dr. Dirk J. Broer**, who will receive the Jan Rajchman Prize for his discovery and development of UV-polymerizable liquid-crystalline polymers; **Candice Brown Elliott**, who will be awarded the Otto Schade Prize for her development of PenTile display technology; **Dr. Han-Ping Shieh**, who will be awarded the Slottow-Owaki Prize for his contributions to the education and training of students and professionals in the display field; and **Jenny Bach**, who will receive the Lewis & Beatrice Winner Award for her sustained services and contributions to the SID organization.*

by Jenny Donelan

**O**NCE AGAIN, the Society for Information Display honors those individuals who have made outstanding contributions to the field of displays, with awards in the category of Fellow and Special Recognition, and also with the Braun, Rajchman, Otto Schade, Slottow-Owaki, and Lewis & Beatrice Winner awards. Recipients are nominated by SID members and selected in a process involving the Honors and Awards Committee and SID's Board of Directors. Fan Luo, chairman of the awards committee, notes that there were many more deserving candidates this year than could be selected.

### Doing More

The winners of this year's major awards can be characterized by their commitment to doing more – sometimes a great deal more. Not one of these individuals was content to sit back and do the same old research or the same old job – they were always trying to learn something new and to make something better.

*Jenny Donelan is the Managing Editor of Information Display Magazine. She can be reached at [jdonelan@pcm411.com](mailto:jdonelan@pcm411.com).*

They kept pushing boundaries and pursuing knowledge even when it would have been reasonable to accept the status quo. While in hindsight it might seem clear that their efforts would lead to recognition and success, this was anything but the case while the years of painstaking research and record-keeping were taking place.

Dr. Katsumi Kondo, this year's Braun Prize winner, saw one technology – in-plane switching – and considered how it might work with another – thin-film transistors – to improve wide-angle viewing in LCDs. At that time, IPS technology was not new, and neither were TFTs. But Kondo used them together to help make possible a whole new phase of the display industry.

Rajchman prize winner Dr. Dirk J. Broer spent a great deal of time working with polymers for telecommunications. When these polymers turned out to be less than ideal for that application, he did not give up, but turned his attention to enhancing display performance with those same polymers, with results that changed displays from then on.

Otto Schade prize winner Candice Brown Elliott began her career as an assistant at a

display company where she could have simply punched the clock, but her curiosity about the company's technology led her beyond administration and into R&D, the results of which enable many of today's best-selling devices.

*The 2014 award winners will be honored at the SID Honors & Awards Banquet, which will take place Monday evening, June 2, 2014, during Display Week at the San Diego Convention Center.*

*Tickets cost \$90 and must be purchased in advance – tickets will not be available on-site.*

*Visit [www.displayweek.org](http://www.displayweek.org) for more information.*



Slottow–Owaki prize winner Dr. Han-Ping Shieh not only nurtured graduates in display disciplines at National Chiao Tung University, but created NCTU’s Display Institute to perpetuate research in Taiwan. His idea of success is sending new display professionals into the industry to seed the future.

And Lewis & Beatrice Winner recipient Jenny Bach, whose curiosity about databases and computer systems led to a career at Apple and then at SID, went beyond the day-to-day to connect with individual members in ways that made the organization more of a community.

This year’s winners all achieved different types of success, but they are similar in their zeal to do more and in their never-ending curiosity about the world around them. Their efforts, often conducted over long weekends and late nights, led to breakthroughs that changed the display industry as we know it. We owe them all a debt of gratitude.

This year’s Honors and Awards recipients will be celebrated by the Society for Information Display during Display Week 2014 at the annual awards banquet to be held on Monday evening, June 2, prior to the Symposium. Tickets for this event are available in advance only by registering at [www.displayweek.org](http://www.displayweek.org).

#### **Karl Ferdinand Braun Prize**

*This award is presented for an outstanding technical achievement in, or contribution to, display technology.*

**Dr. Katsumi Kondo**, SID Fellow and a member of the Corporate Research and Development Group at Sharp Corp., will receive the Karl Ferdinand Braun Prize “for his pioneering contributions to the research and development of in-plane-switching (IPS) TFT-LCD technology, leading to the first commercialization of LCDs with intrinsically wide-viewing-angle characteristics.”

Back in the early 1990s, when cathode-ray tubes (CRTs) were the dominant display technology, liquid-crystal displays were considered possible replacement candidates, but their viewing angle was far inferior to that of CRTs, especially when used in large formats such as TVs and monitors. Production costs for LCDs were also greater. At that time, Dr. Katsumi Kondo, a senior researcher at Hitachi, became intrigued by the in-plane-switching (IPS) mode originally suggested by SID Fellow Dr. Gunter Baur as a possible way to improve viewing angle in LCDs. Kondo

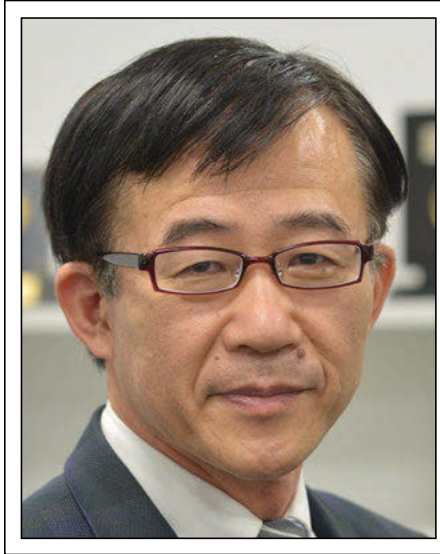

*Dr. Katsumi Kondo*

and his group at Hitachi devised a method of combining IPS with thin-film transistors so as to enable angular-independent LCD operation. The team succeeded in reducing the number of conducting layers per pixel from 4 to 2 (compared with existing TFT TN-LCDs) and also invented zig-zag electrode patterns for IPS-LCDs to create multi-domain LC pixels. These developments eliminated color shift in TFT-addressed IPS-LCDs and made TFT-addressed IPS-LCDs a key technology for large-sized TVs.

The idea of combining these technologies was far from obvious at the time, and the initial impact may be understood from reactions to Kondo delivering a paper on IPS-TFT LCDs at Asia Display in 1995 in Hamamatsu, Japan. Shigeo Mikoshiba, SID Fellow and Past-President, describes the scene: “I clearly remember that at 8:30 in the morning, I found crowds of people who were not able to get into the conference room because it was already fully packed. Since I was then program committee chair, my immediate worry was: ‘Did I make a mistake in the facility assignment?’” But Mikoshiba soon discovered that the crowds were there due to the buzz over Kondo’s presentation. “A demo exhibition of his device at Asia Display enchanted every visitor,” adds Mikoshiba. Since that time, and for many years afterward, IPS-TFT LCDs were the mainstay of LCD production.

Mikoshiba adds that Kondo is not only a dedicated researcher, but an active volunteer.

“Dr. Kondo showed excellent leadership in the display community as the SID Japan Chapter Chair and the SID Japan Chapter Director,” says Mikoshiba.

Kondo received his B.S. degree in engineering from Tokyo University of Agriculture and Technology and went on to earn his M.S. and Ph.D. degrees from Tokyo Institute of Technology. He began working at Hitachi Research Laboratory in 1983 and eventually became a Senior Chief Researcher for Displays before joining Sharp, where he is now a Unit General Manager. He has also taught at several institutions, including Kyushu University, where he is currently a Visiting Professor.

#### **Jan Rajchman Prize**

This award is presented for an outstanding scientific or technical achievement in, or contribution to, research on flat-panel displays.

**Dr. Dirk J. Broer**, Professor at Eindhoven University of Technology, will receive the Jan Rajchman Prize, “for his pioneering discovery and development of UV-polymerizable liquid-crystalline polymers and his outstanding contributions to their applications in flat-panel displays.”

“It is really quite easy to say that the field of displays and current display products would not be the same, and notably less advanced, if not for the contributions of Professor Broer,” says Philip Bos, Associate Director of the Liquid Crystal Institute at Kent State University. Broer, a polymer chemist who began his career in 1973 at Philips

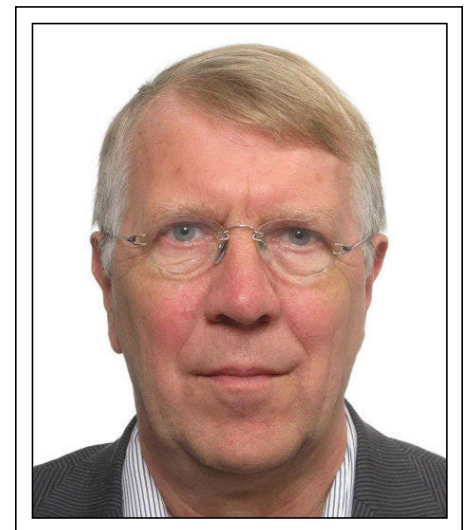

*Dr. Dirk J. Broer*

## SID's best and brightest

Research in Eindhoven, The Netherlands, is the inventor of UV-polymerizable liquid-crystalline materials that made possible advances such as fast-switching vertically aligned displays, high-pretile generation, the formation of patterned retarders for 3-D, the stabilization of photo-alignment, polarization gratings, multi-domain displays with wide viewing angle, wide-bandwidth cholesteric displays, and more. Broer began working with liquid crystals at Philips as part of an optical telecommunications project. His invention was a technical success, he says, but the materials were expensive and there were other, more economical solutions. "After the telecommunication adventure," says Broer, "it soon became clear that the optical properties of the liquid-crystal networks polymer films were of more interest." Using the same liquid-crystal monomer he had developed earlier with his Philips colleagues, Broer turned toward enhancing display performance.

According to Bos, "Broer has shown how to solve many problems in the area of displays through breakthrough new ideas. In particular, his impact on the field of polymer-stabilized liquid-crystal displays and on optical components using his reactive mesogens is incredible. Many researchers, including myself, have used his materials, or derivatives of his materials, when considering new device advances."

Broer became interested in chemistry as a high-school student. He received his Ph.D. from the University of Groningen, where he specialized in polymer structuring and self-organization, explaining that he chose polymer chemistry because of its close relationship to practical applications. "That is also why I chose a career at Philips," he says, "where fundamental science could be combined with product development."

Some of Broer's inventions have yet to be used and some are still in development. At one point in his career, he developed a "paintable display technology" that applies the liquid-crystal mixture to the substrate in one step. As far as he knows, this has not been used commercially. A challenge his team is currently working on is to create mechanically responsive touch screens making use of order-disorder transition in liquid-crystal polymers.

In all, Broer has devoted more than 25 years of his professional career to researching

material and technology optimization of UV-polymerizable liquid crystals in different areas, including displays. Research in this field has resulted in more than 220 publications and more than 120 U.S. patents. Since 2010, he has been a full-time professor in

Eindhoven specializing in functional organic materials for clean technologies including energy harvesting, water treatment, and healthcare applications. He is also a consultant at Merck.

## 2014 SID Fellow Awards

*The grade of fellow is conferred annually upon SID members of outstanding qualifications and experience as scientists or engineers whose significant contributions to the field of information display have been widely recognized*



**Chihaya Adachi**, "For his outstanding contributions to the science and technology of organic light-emitting devices including materials and device structures." Dr. Adachi is

the director of the Center for Organic Photonics and Electronics Research (OPERA) at Kyushu University. He received his doctoral degree in engineering from Kyushu University.



**Janglin Chen**, "For his leading contributions to the development of flexible displays, substrate technology, and thermally rewritable electronic paper." Dr. Chen is a

Vice-President of the Industrial Technology Research Institute (ITRI) in Taiwan and the General Director of the Display Technology Center at ITRI. He has a Ph.D. in chemistry from the Polytechnic Institute of New York University.



**Victor Belyaev**, "For his many contributions to the science and technology of liquid-crystal materials, electro-optical modes, displays, components, and systems." Dr. Belyaev is

a Principal Scientist with Moscow Region State University. He received his Ph.D. in physics from Moscow Institute for Physics and Technology and his Dr.-Eng. habil. in optic and optoelectronic devices from Central R&D Institute Kometa.



**Yong-Seog Kim**, "For his many contributions to the science and technology of plasma display panels including the development of secondary-electron-emitting materials, the

exo-electron emission phenomenon, and advanced material processing for information displays." Dr. Kim is a Professor with Hongik University. He earned his Ph.D. in Materials Science and Engineering from Massachusetts Institute of Technology.



**Taiichiro Kurita**, "For his outstanding contributions to the research and development of display image-quality characterization and high-quality display systems, particularly those

involving the presentation of moving images on active-matrix displays." Dr. Kurita is an Executive Research Engineer with NHK (Japan Broadcasting Corporation). He received his Ph.D. from Keio-Gijuku University.

## Otto Schade Prize

*The Otto Schade Prize is awarded for an outstanding scientific or technical achievement in, or contribution to, the advancement of functional performance and/or image quality of information displays.*

**Candice Brown Elliott**, CEO and Founder of Nouvoyance, Inc., receives the Otto Schade Prize this year “for the development of PenTile display technology, a key enabler of power-efficient high-resolution mobile OLED and LC displays based on subpixel rendering of color pixel arrangements.”

Candice Brown Elliott grew up in Silicon Valley at a time when the high-tech industry as we know it was poised to begin. Her first job in that sector was with CMX Video Systems, where she worked as a secretary to pay her way through college. While at CMX, she began learning about video technology, and thus began a life-long involvement with video and displays. She eventually earned a B.S. degree in science and psychology from the State University of New York and continued to further her practical education as well, holding a number of positions in display-related fields, including 3 years as an engineering supervisor at Planar Systems.

In 2000, she founded Clairvoyante, based on PenTile display technology that had its roots in her work at Planar. “I was working



Photography by Carolyn P. Reed/CPR Photography © 2014.

## Candice Brown Elliott

[at Planar] on the color thin-film electroluminescent (EL) project in the early ‘90s, focused on the problem of bringing the cost of electronics and packaging down, when I began toying with the idea of reducing the number of drivers, which were expensive, and the number of electrical interconnects, which were at the time very bulky, by using novel color subpixel layouts and subpixel-rendering algorithms,” says Elliott.

The PenTile method for subpixel sharing within pixels improves the resolution of the display while maintaining color balance and mix. The structure of the subpixels is optimized based on human-factors models, and the relative area of the mix of subpixels is also optimized for best luminance. According to Joel Pollack, Senior Manager of Display Engineering at Lab126 and a former colleague of Elliott’s, “Candice has made a key contribution to enabling high-resolution displays for mobile devices with PenTile display technology.”

One of the greatest challenges of introducing PenTile to the display industry was that for a time it was a solution to a problem that did not exist. When Clairvoyante was founded, notes Elliott, the market was not quite ready for high-resolution mobile displays, and therefore did not need better ways of implementing them. With the introduction of smartphones this changed, and PenTile is now used in a variety of mobile devices and also some TVs.

Clairvoyante was purchased by Samsung in 2008 and Elliott then founded the independent company Nouvoyance, which continues to support PenTile and other display technology for Samsung. Says Dr. Sung Tae Shin of Samsung, “Over the 4 years that I worked with Candice and her team, I developed a keen appreciation of the PenTile technology and its impact upon mobile displays and

## 2014 SID Special Recognition Awards

*Presented to members of the technical, scientific, and business community (not necessarily SID members) for distinguished and valued contributions to the information-display field*



**Mark Spitzer**, “For contributions to the developments of active-matrix-liquid-crystal micro-displays, microdisplay viewing optics, and wearable computer technology.” Dr. Spitzer is a Director of Operations at Google, where he works in the Google [X] Laboratory. He received his Ph.D. in physics from Brown University.



**Zenichiro Hara**, “For his leading contributions to the development of the super-sized display with seamlessly tiled OLED panels.” Dr. Hara is an engineer with Mitsubishi Electric Corp. He received his Doctor of Engineering degree from Nagasaki University.



**Hyun Jae Kim**, “For his pioneering development of low-temperature-polysilicon (LTPS) TFT and solution-processed oxide-TFT technologies.” Dr. Kim is a Professor with the School of Electrical and Electronic Engineering at Yonsei University. He earned his Ph.D. in Materials Science and Engineering from Columbia University.



**Changhee Lee**, “For his leading contributions to the research and development of organic light-emitting diodes (OLEDs) and quantum-dot LEDs for full-color displays and solid-state lighting.” Dr. Lee is a Professor with the School of Electrical and Computer Engineering at Seoul National University. He earned his Ph.D. in physics from the University of California at Santa Barbara.

## SID's best and brightest

associated consumer products. It was a key enabler for high-resolution mobile OLED displays and is now beginning to see adoption into high-resolution tablet products." PenTile technology has been used in devices such as the Samsung Galaxy Note and SIII.

Elliott has 84 U.S. patents issued with more pending and many more foreign patents issued and pending. She is a visiting fellow at Nottingham Trent University.

### Slottow–Owaki Prize

*The Slottow–Owaki Prize is awarded for outstanding contributions to the education and training of students and professionals in the field of information displays.*

**Dr. Han-Ping Shieh**, an NCTU Professor and Vice-Chancellor at National Chiao Tung University, will receive the 2014 Slottow–Owaki Prize "for his exceptional contributions to the education and training of students and professionals in the display field and the promotion of display science and technology."

Dr. Han-Ping Shieh has taught at the university level for more than 20 years and has advised more than 100 M.S. and Ph.D. students in display-related fields, published more than 160 journal papers, and obtained more than 60 patents (with 40 more still pending). He also founded the Display Institute (DI) at National Chiao Tung University (NCTU) and helped other major Chinese universities to establish display-related institutes in their engineering schools. He is a veritable force for displays in Taiwan and China.



*Dr. Han-Ping Shieh*

"Dr. Shieh's contribution to the promotion of professional activities as well as to the sustained growth of the Taipei Chapter of SID is exceptional and well-known," says Fred Chen, SID Fellow and Chief Scientist of Guangdong Aglaia Optoelectronic Materials, Co., as well as a former Professor at NCTU. "If one were to single out his most outstanding achievement, it has to be the founding of the first display institute in Asia dedicated to graduate student education and training of display professionals, at NCTU in 2003."

The institute came about, says Shieh, because in the late 1990s, NCTU was well-known for microelectronics and photonics, but did not have the same foundation for the study of displays, which were becoming significant to industry in Taiwan at this time. Shieh was asked by the president of NCTU to found the institute, which started out with three people and expanded from there. In 2003, the DI gained its own facility (the CPT building, donated by and named after Chunghwa Picture Tubes), so that all the labs, faculty, and students could be accommodated under one roof. "Of course, NCTU already had substantial resources in microelectronics fabrication, labs, and expertise, which made my job of establishing the DI much easier," says Shieh.

Teaching has proved very gratifying to Shieh over the years. When asked about the highs and lows of working with students, Shieh says there are really no lows. "Most of them are very smart and willing to take on challenges," he says. One of his greatest satisfactions has been to see large numbers of students go on to become high-level executives at display or display-related companies. "I have a bi-annual gathering at the lab, which is usually attended by more than 70 former students and their families," he says.

Shieh received his B.S. degree from National Taiwan University and went on to receive his Ph.D. in electrical and computer engineering from Carnegie Mellon University. He joined NCTU in 1992, where he was the Dean of the College of Electrical and Computer Engineering from 2006 to 2010, and then a senior Vice President from 2011 to 2013. He has pursued projects in private industry from time to time, but feels most at home in academia. His current research interests are displays, optical MEMS, nano-optical components, and solar energy.

### Lewis & Beatrice Winner Award

*The Lewis & Beatrice Winner Award for Distinguished Service is awarded to a Society member for exceptional and sustained service to SID.*

**Jenny Bach** will receive the Lewis & Beatrice Winner award "for her sustained services and contributions to the operations and growth of the SID organization."

For more than 10 years, Jenny Bach was "the face of SID," in the words of former SID President Larry Weber, working as the data manager for the Society's California headquarters, but also serving as the main point of contact for SID's thousands of members. During her tenure with SID, she saw many changes, including a membership increase in the thousands, the addition of new chapters around the world, and an increased involvement by students, particularly international students.

In her own words, she saw her job as "making sure that members got what they wanted," but that was not always a simple task. According to SID Fellow and Otto Schade prize recipient Adi Abileah, "She put in a huge effort, much above the call of duty, for the organization. She was always responsive to any small or big problem, sometimes at crazy hours of the day."

Weber began to work with Bach in 2006, when she was solely responsible for running the SID headquarters. "I found that Jenny operated the SID office very efficiently and with great enthusiasm," says Weber. "As



*Jenny Bach*

president, I had to continually rely on her great knowledge of SID, her understanding of the needs of the many individual SID members, and her ability to quickly and efficiently get some hot project done.”

Other SID past-presidents echo these sentiments. According to Tony Lowe, “Throughout her time in SID’s employment, Jenny performed superbly. I found her always helpful and willing to go the extra mile. Lowe describes Bach’s manner in dealing with members, from executive to new recruit, as “calm, friendly, and very effective.” He adds: “I have received unsolicited praise for Jenny and her work for SID from all corners of the globe.” Says Past President Allan Kmetz, “What makes her long service to SID deserving of this award is her outstanding dedication, individual initiative, diligence, and reliability, as well as personal loyalty and warmth.” As testament to these efforts, Bach received five Presidential Citations from SID during her time with the Society.

Bach received her B.A. degree in Interdisciplinary Studies in Social Science from San Francisco State University, where she also studied data management. She joined Apple Computer in 1984 as a data entry clerk and worked there for 12 years, eventually becoming a network administrator for the Instructional Products Department. When she joined SID in 1998, she used her data and IT expertise to streamline operations for the organization. She also discovered what it was like to work for an organization aimed at serving members. Although Bach describes herself as “a real data person,” she is obviously also a people person: “I really enjoyed all the interactions with members,” she says, adding that it was her particular pleasure to get to know members of chapters from all over the world. ■

## Symposium Special Topics of Interest



# Display Week 2014

SID International Symposium, Seminar & Exhibition

- OLED TV
- Lighting
- Wearable Displays
- Oxide vs. LTPS TFTs
- 3D

San Diego Convention Center, San Diego, CA, USA

June 1-6, 2014

[www.displayweek.org](http://www.displayweek.org)

## JOIN SID

We invite you to join SID to participate in shaping the future development of:

- Display technologies and display-related products
- Materials and components for displays and display applications
- Manufacturing processes and equipment
- New markets and applications

In every specialty you will find SID members as leading contributors to their profession.

<http://www.sid.org/Membership.aspx>

### Submit Your News Releases

Please send all press releases and new product announcements to:

Jenny Donelan

*Information Display Magazine*

411 Lafayette Street, Suite 201

New York, NY 10003

Fax: 212.460.5460

e-mail: [jdonelan@pcm411.com](mailto:jdonelan@pcm411.com)

**VISIT  
INFORMATION  
DISPLAY ON-LINE**

[www.informationdisplay.org](http://www.informationdisplay.org)

# Reflection Performance in Curved OLED TVs

*One of the creators of the IDMS (Information Display Measurements Standard) takes the measure of the latest large, curved OLED TVs. In this second article in a series, he looks at reflection performance and makes a discovery that may necessitate a revision to the reflection measurement procedure in the IDMS standard.*

by Edward F. Kelley

**B**ECAUSE televisions are usually viewed in some sort of ambient condition, it makes sense to see how well they handle ambient illumination and the surround. In this article, we compare the reflection performance of two recently released curved organic light-emitting-diode (OLED) television (TV) displays: an LG 55EA9800 and a Samsung KN55S9CAFXZA. Both are 55-in. OLED [active-matrix OLED (AMOLED)] units. As discussed in the first article in this series, “Considering Color Performance in Curved OLED TVs,” in the November/December 2013 issue, we say “usually viewed” because there are situations where the ambient influence from the surround is virtually non-existent, as with a serious gamer in a very dark room. In one way or another, most of us have to contend with rooms with ambient light.

In keeping with the testing methodology from the first article, only one display from each manufacturer was measured, so a statistical sampling was not provided.<sup>1,2</sup> Also, keep in mind that manufacturing details can change as newer displays are released and their properties can change.

Lastly, during the course of testing, we discovered that a complete reconsideration of the material in Chapter 11 on reflection in the IDMS document and especially the section on

ambient contrast is almost certainly required. Read on.

## Quick Visual Inspection with Point Source

One of the best ways to *visually* inspect the reflection properties of any display is to use a point source. [Figure 1](#) shows a quasi-Lambertian light-emitting diode (LED) in front of and between the two OLED displays. (A flashlight with a bare bulb will work similarly.) Your eye can see much more than this picture can possibly show. The dynamic range of these point-source reflections can be from  $10^5$  to  $10^7$  (and possibly more), and you can see that range of luminance with your eye – it is essentially a type of bidirectional reflectance distribution function (BRDF)

where the source and target remain fixed and the detector observation direction changes.

To capture that same dynamic range with photography requires multiple images of varying exposures.<sup>3</sup> What we see in these point-source images tells much of the story about the display reflection properties: We see primarily a specular (regular, mirror-like) reflection with matrix scatter in both displays. The LG display is apparently employing an anti-reflection front surface (a magenta hue), and the Samsung display exhibits a very wide matrix-scatter distribution. Neither display has a strong diffusing front surface, so there is essentially no haze component of reflection. It would appear from this photograph that we will see more reflection from the Samsung

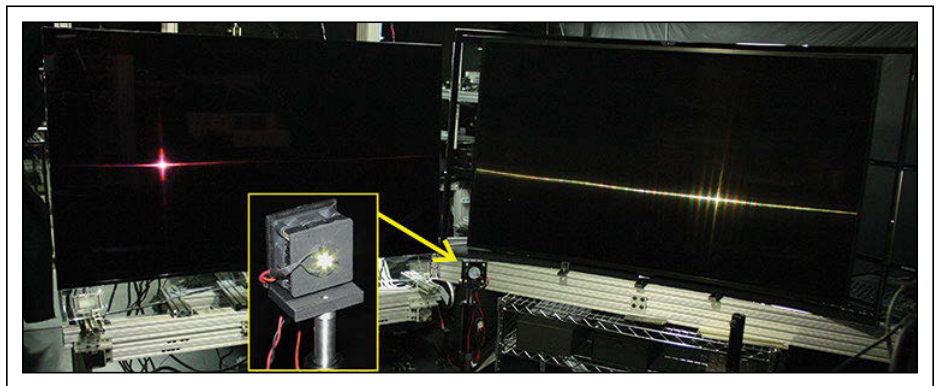

**Fig. 1:** Point-source reflection is shown with the LG display on the left and the Samsung on the right. The inset shows the front of the LED point source. The displays are in a normal viewing arrangement with their surfaces tilted back a few degrees.

*Ed Kelley is a consulting physicist with Keltek LLC in Longmont, Colorado. He can be reached at [ed@keltekresearch.com](mailto:ed@keltekresearch.com).*

OLED display than the LG OLED display, in general. For a discussion of the various components of reflection, see the IDMS, Chapter 11, Reflection, and especially the Appendix B17 Reflection Models and Terminology.<sup>4</sup>

### White-Screen Anomaly

Usually, we would worry about reflections from both the white and the black displayed colors. Unfortunately, to obtain reliable reflection measurements with white showing it is necessary that the reflected luminance be measurably greater than the display white. This often requires illumination levels that are not commonly encountered in a normal TV viewing experience. The assumption has always been that linearity and superposition hold so that we can make laboratory measurements of these displays to obtain their reflection parameters and then scale and combine the results in appropriate ways to replicate any ambient environment desired (see IDMS § 11.9 Ambient Contrast).

In this case, we observed an anomalous behavior in the Samsung OLED that we have never seen before. Whereas with liquid-crystal displays (LCDs), we expect to see a small difference in the reflection properties between white and black, such would not be expected in OLED displays. However, for the first time, we found that the Samsung OLED exhibited a darkening of white that was somehow proportional to the illuminance level. This made it impossible to reliably measure the reflection properties with the source illuminance levels we would normally use when attempting to measure the reflection from white.

This development is both problematic and a remarkable result in that superposition does not hold true for such large illuminance conditions on this particular OLED display. This change in white luminance with strong illuminance did not occur for the LG OLED display. However, it is important to note that Fig. 2 shows that for illuminances well below 10 klx, the white level on the Samsung OLED is not as affected. For the purposes of this article, we will assume that the reflectance of white and black are the same for the Samsung OLED display; it is simply unfortunate that we could not verify that assumption directly for low illuminance levels. Thus, we will only report the reflection parameters for black for both of these OLED displays and use those parameters accordingly. The white and black

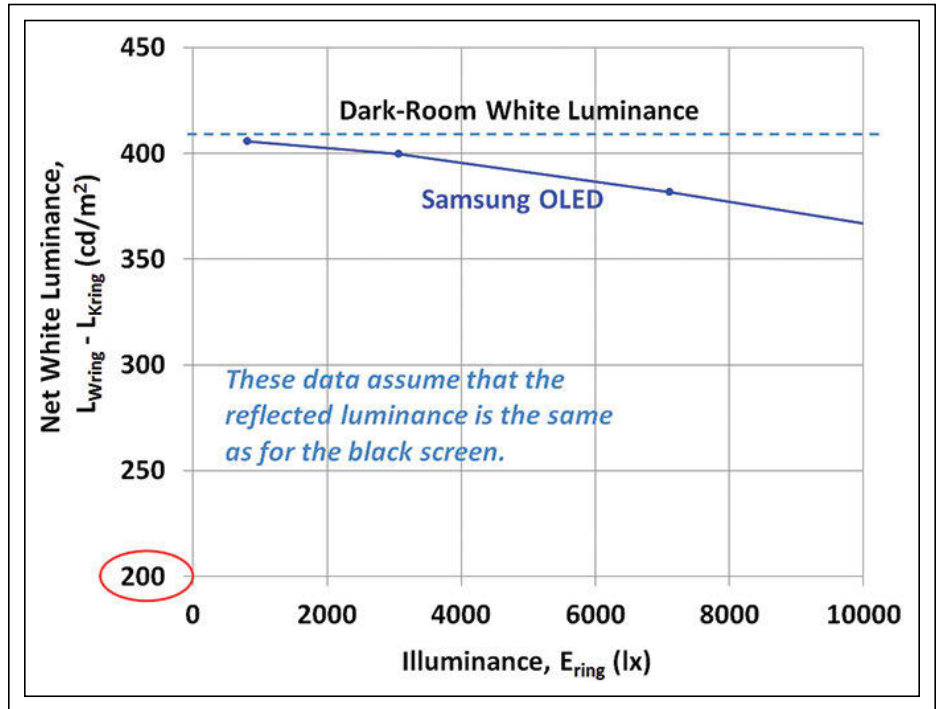

**Fig. 2:** Assuming that the reflected luminance is the same for black as it is for white, this chart shows what the decrease in white luminance with illuminance for the Samsung OLED display might be.

reflection parameters are the same for the LG display within the uncertainty of our measurements.

### Reflection Measurement Results

Next, we will examine and compare six reflection properties: diffuse reflectance with specular included, diffuse reflectance with specular excluded, ring-light luminance factor, dual-source luminance factor, specular reflectance for a 15° uniform source, and an in-horizontal-plane BRDF with stationary source and moving detector.<sup>5</sup> In all but the BRDF measurements, spectral data are obtained so that spectral-reflectance-factor calculations could be performed; we chose the common photometric reflection parameters for simplicity. In general, the relative expanded uncertainty with a coverage factor of two is 5% for most of these measurements and 10% or more for the BRDF measurements. These displays are tilted back for typical viewing *via* their frames or mounts; hence, we had to tilt them forward so that their central surfaces were vertical. The reflection for the display turned off and at room temperature might be slightly different than the display

being fully warmed up and showing a full black screen. (Any filter material generally has a small change in transmission with temperature.) The difference, if any, is also within the uncertainty of these measurements. However, for all measurements reported here, the displays are warmed up and showing black. A 17-level 25%-screen-size APL pattern with either a white or black center was used until it was established that a full-screen black had the same reflection properties as the APL pattern with a black center.

Table 1 provides the summary of results of this study. Each reflection parameter measurement will be discussed separately below. For all parameters except the specular reflectance and the BRDF maximum, the LG OLED display exhibited less reflection than the Samsung OLED display. When we examine the BRDF profiles as well as the point-source photograph (Fig. 1), we can understand why: The Samsung OLED distributes more of the energy in a wide-angle pattern because of the wide matrix scatter; this results in less energy in the specular direction, whereas the LG OLED display exhibits less matrix scatter and more of the energy remains in the specu-

**Table 1:** These reflection results are based on display black (assumed the same for white).

Reflection Property:	Diffuse Reflectance		Luminance Factors		Specular Reflectance	BRDF
Reflection Parameter: /Display	Specular Included $\rho_{di/10}$	Specular Excluded $\rho_{de/10}^*$	$\beta_{ring}$	$\beta_{dual}$	$\zeta$	Maximum (sr <sup>-1</sup> )
LG OLED	0.0194	0.00113	0.00055	0.00128	0.0224	161
Samsung OLED	0.0450	0.0282	0.0128	0.309	0.0218	127

\* Note: Because of the presence of matrix scatter, these values of the diffuse reflectance with specular excluded may be very sensitive to apparatus geometry (size of sphere and size of specular port).

lar direction with less scattered out of the specular direction.

Recall that the term “diffuse” refers to light scattered out of the specular (or regular, mirror-like) direction. In making diffuse-reflectance measurements (using an integrating sphere to provide a uniform hemispherical illumination), we can include the specular component or exclude it *via* a second hole to not measure the light from the specular direction. Thus,  $\rho_{di/10}$  refers to the diffuse reflectance with specular included measured at 10° from the normal of the sample material, and  $\rho_{de/10}$  refers to the diffuse reflectance with specular excluded measured at 10°. For such hemispherically uniform illumination, the diffuse reflectance is given by  $\rho = \pi L/E$ , where  $L$  is the net reflected luminance and  $E$  is the illuminance. The luminance factor  $\beta = \pi L/E$  has the same mathematical form, but the net reflected luminance is not from a uniform hemispherical source of illumination but from either a ring light or dual isolated sources in our case. The specular reflectance  $\zeta = L/L_s$  is the ratio of the net reflected lumi-

nance to the source luminance for a discrete source having a subtense of 15°. (This is not strictly the specular reflectance as would be obtained from a high-resolution BRDF measurement, but it is an approximation to the true specular reflectance that is much easier to measure and useful whenever there is a strong specular component. (See IDMS Chapter 11 and § B17 for a full discussion of these reflection components.)

To provide an example of how these reflection parameters might be used in an ambient contrast calculation, we show in Table 2 an example of a TV viewing room as specified in IDMS § 11.9 Ambient Contrast with a hemispherical uniform surround illuminance of 60 lx and another 40 lx possible from isolated lamps in the room. The ambient contrast is the ratio of the white luminance with the reflected luminance added divided by the black luminance (zero for these OLEDs) with the reflected luminance added in. We employed Eq. (1) of IDMS § 11.9 to calculate the ambient contrast. In the last three columns we compare the ambient contrast (1)  $C_A$  with both the

uniform hemispherical surround and the two sources placed at ±30° to maximally interfere with the TV picture, (2)  $C_A'$  with a hemispherical surround and the ring light to simulate several widely placed sources around the room and ceiling at 45° locations, and (3)  $C_A''$  without any isolated or directed sources and just the diffuse uniform hemispherical surround. Even with the mild illumination for the TV viewing room, the contrasts are reduced considerably from what is seen in the darkroom. The nice thing about this kind of ambient-contrast calculation in IDMS § 11.9 is that we can change the values as we wish to simulate the performance in other surrounds – such as for a very dark home theater – and recalculate the result. For example, if we only had a hemispherical uniform surround illuminance of 10 lx and no isolated sources, we would have an ambient contrast (third column)  $C_A''$  of 6460 and 2850, respectively, for the LG and Samsung OLED displays.

**Diffuse Reflectance with Specular Included**

The IDMS contains § 11.2 Hemispherical Reflection, Specular Included, and we use here § 11.2.2 Sampling-Sphere Implementation. Figure 3 shows the arrangement for both the sampling-sphere measurement of diffuse reflectance with specular included and excluded.

Ultimately, we only measured and report here the black reflectances. The white light-emitting-diode (LED) illuminance at the sample port was between 78 and 24 klx (depending upon the LED current setting) based upon wall measurements that were calibrated to have a reflectance of 0.98 according to the procedure in the IDMS § 11.1.3.1 Inte-

**Table 2:** Example of an ambient-contrast-calculation result.

	Illuminance Configurations			Darkroom Luminances (cd/m <sup>2</sup> )		Ambient Contrasts		
	$E_{hemi}$ (lx)	$E_{dir} = E_{dual}$ (lx)	$E_{dir} = E_{ring}$ (lx)			Both ** $E_{hemi} + E_{dual}$	Both $E_{hemi} + E_{ring}$	Only Hemi. $E_{dir} = 0$
	60	40	40	$C_A$	$C_A'$	$C_A''$		
	$\rho_{di/10} E_{hemi} / \pi$ (cd/m <sup>2</sup> )	$\beta_{dual} E_{dir} / \pi^*$ (cd/m <sup>2</sup> )	$\beta_{ring} E_{dir} / \pi$ (cd/m <sup>2</sup> )	$L_W$	$L_K$			
LG OLED	0.371	0.016	0.007	399	0	1033	1058	1078
Samsung OLED	0.859	3.93	0.163	408	0	86	400	476

\* We will assume that there are two such lamps in the ±30° arrangement used to measure the luminance factor for the dual-source configuration.  
 \*\* Such lamps would also have to be arranged so that their matrix scatter would interfere with the viewed picture area on the TV.



grating-Sphere Sources for Uniform-Diffuse Surrounds under item #4 Wall Luminance (Sample Sphere). The spectroradiometer ( $1^\circ$  aperture, 4-nm bandwidth) was placed back approximately 1 m from the measurement port of the sampling sphere to avoid any stray light from the wall during sample-port measurements. The angle of the measurement port from the normal of the sample port and TV is  $10^\circ$ . The spectroradiometer can swing sideways to measure either through the measurement port at the center of the sample port or at the wall next to the sample port. The diffuse reflectances with specular included for the LG and Samsung OLED displays were 0.0194 and 0.0450, respectively.

### Diffuse Reflectance with Specular Excluded

Here, we use the procedure outlined in § 11.3 Hemispherical Reflection Specular Excluded and 11.3.2 Sampling-Sphere Implementation (Specular Excluded). With the specular port removed, there is between 72 and 22 klx falling upon the sample port. The measurements proceed as with the specular-included configuration, except that the spectroradiometer must be carefully positioned so that the virtual image of the specular port is in the center of the sample port and measurement port and so that the measurement is made at the center of the virtual image of the specular port. The display surface at the sample port is kept in focus. The detector distance of 1 m from the measurement port assures no interference from the out-of-focus vignettes of the measurement and specular ports. It is important to note that unless the display reflection is purely specular and/or Lambertian in nature, the size and distance of the specular port may change the measurement result whenever matrix scatter or haze is present in the reflection components. Thus, the specular-excluded measurement results may not be reproducible in other laboratories. The rest of the reflection parameters we measured should be reproducible in other laboratories. The diffuse reflectances with specular excluded for the LG and Samsung OLED displays were 0.00113 and 0.0282, respectively.

### Ring-Light Illumination

In the IDMS 11.5 Ring-Light Reflection, suggestions are made regarding the geometry of the apparatus. The ring light used in our tests had a diameter of 197.1 mm, and the

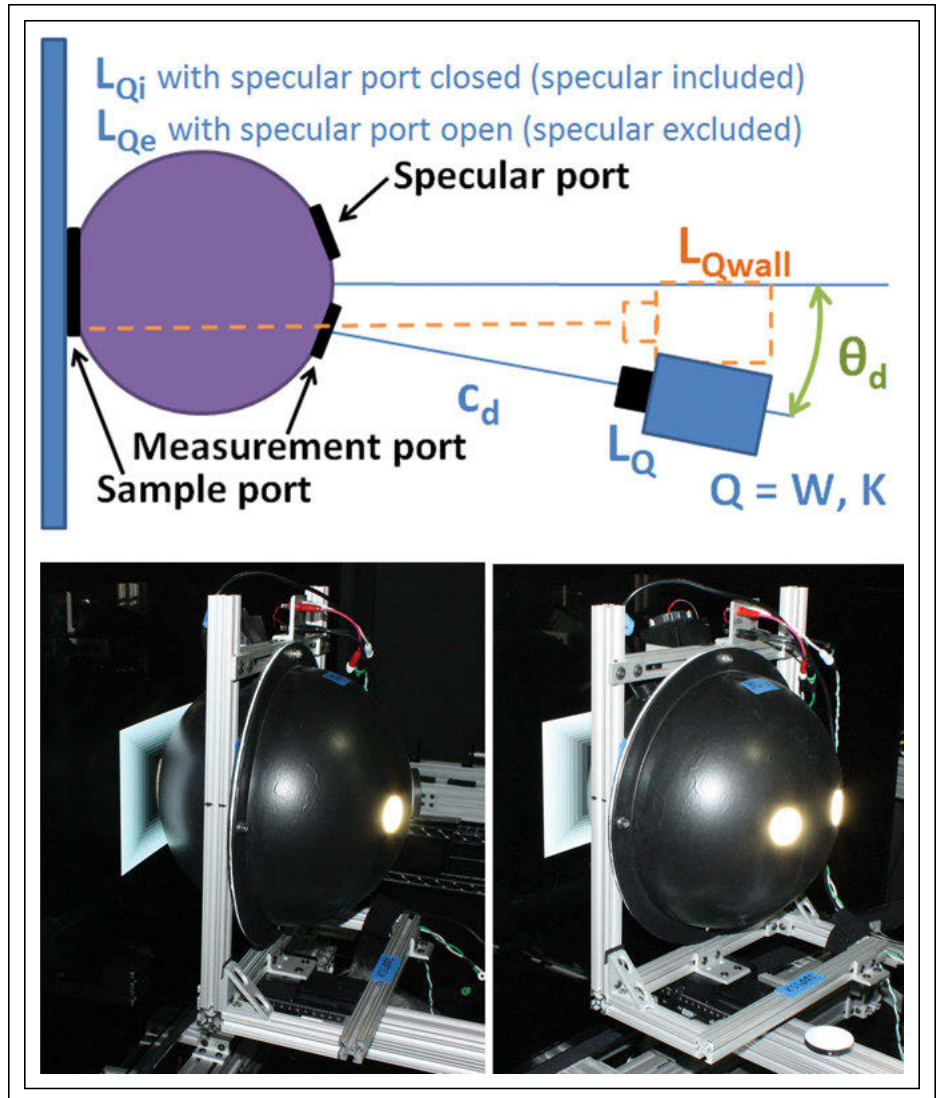

**Fig. 3:** A sampling sphere was used to measure the diffuse reflectances for both specular-included and specular-excluded configurations. Only  $Q = K$ , black, measurements are reported in this article.

requirement for a  $45^\circ$  illumination direction called for it to be placed a distance of 98.6 mm away from the center of the screen. The radial width of the ring of light was 0.44 mm, which gave it a subtense of  $0.1^\circ$ , well under the required  $<0.5^\circ$ . At full brightness, the illuminance at screen center was approximately 48 klx from a tungsten-halogen bulb with an IR cutoff filter. Figure 4 shows the steps taken to make ring-light measurements: (a) The ring light was carefully positioned at the proper distance using a special device to gently touch the display without damage.

(b) A thin white target whose reflectance was previously calibrated for  $45^\circ$  illumination was placed at the center and its luminance measured to provide the illuminance from the ring light. (c) The measurement of the center region was made with the spectroradiometer placed at a detector distance of approximately 180 cm. (See IDMS 11.1.3.2 Discrete or Directed Uniform Sources and Ring Lights for a suggested method to determine illuminance from a ring light when the display cannot be moved.) Figure 5 illustrates the geometry and shows the view from the detector of both

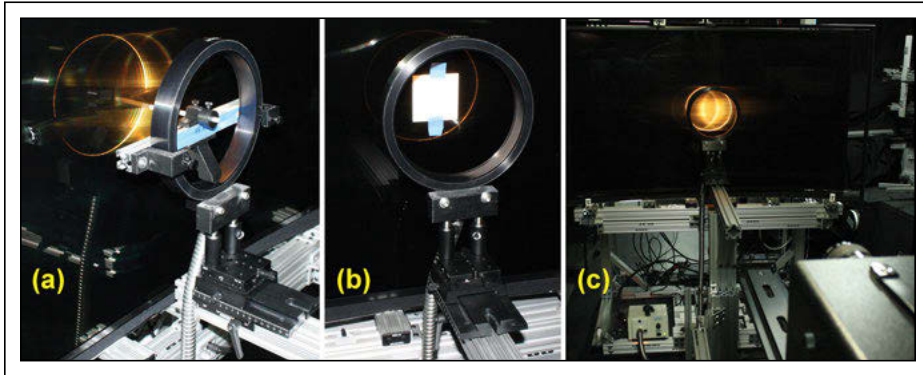
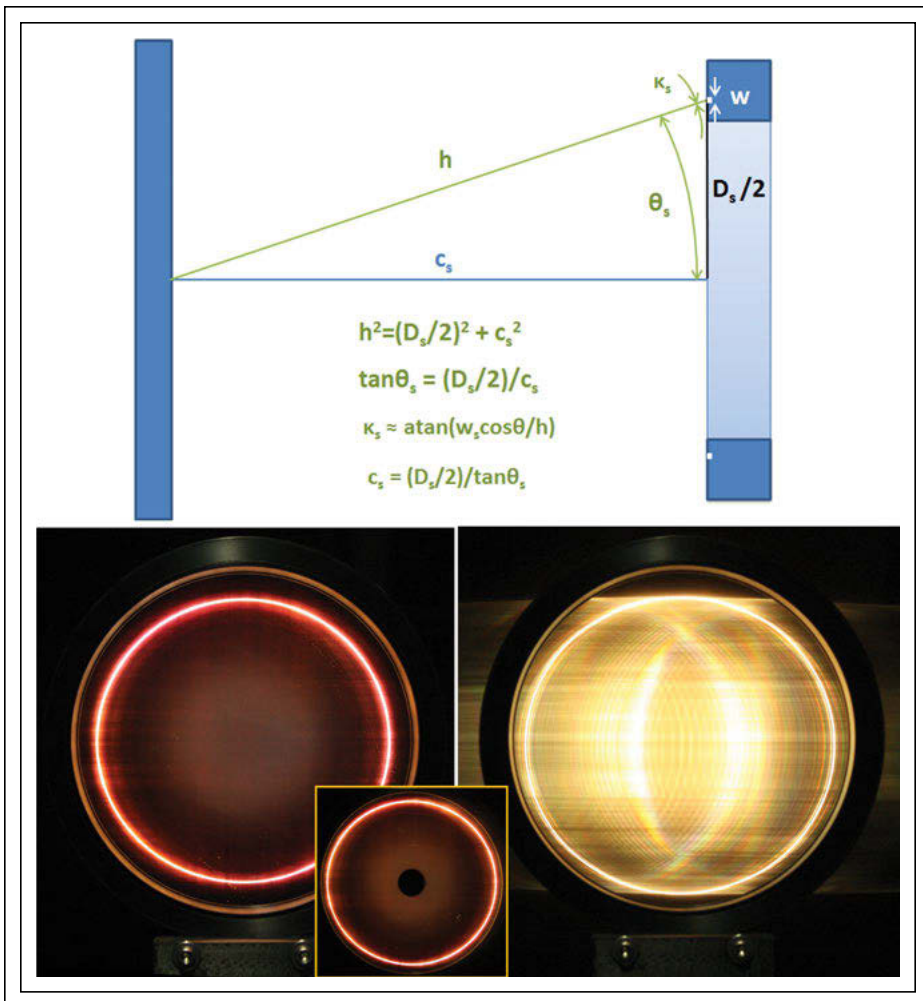

Fig. 4: From left to right are the steps used to make a ring-light reflection measurement.

OLED screens under ring-light illumination. Because the LG OLED display has a relatively confined matrix scatter, the measured region is dark. Conversely, the Samsung OLED has a matrix scatter that is widely

distributed as manifested by the patterned reflection of the ring light. The ring-light luminance factors for the LG and Samsung OLED displays were 0.00055 and 0.0128, respectively.



### Dual-Source Reflection

Here, we followed the recommendations of IDMS § 11.7.2 Dual-Large Source Reflection, which specify that the sources be placed at distances of 500 mm or more, subtend  $15^\circ$ , and are placed at  $\pm 30^\circ$  on each side of the normal. The detector was positioned to view down the normal of the display (see Fig. 6). We were using box sources with 150-mm-diameter exit ports and tungsten-halogen lamps running at 2856 K. The sources exhibited a non-uniformity of less than 0.25 % (see IDMS 11.1.3.2 Discrete or Directed Uniform Sources and Ring Lights for a suggested uniformity diagnostic). The procedure was similar to that of the ring-light measurement: We obtained the correct distances needed, placed a thin white target on the display surface that had been calibrated for this  $30^\circ$  angle illumination, then measured the reflected luminance with a black screen. The resulting illuminance was 995 lx. Figure 7 shows the appearance of the reflection for both displays from the direction of the normal. The strong matrix scatter of the Samsung OLED results in a rather bright smearing of the sources, but also note the oscillations along the horizontal direction in that reflected light. This oscillation in the luminance increases the uncertainty in the measured reflected luminance. We tried to obtain a reasonable average in the vicinity of center for the Samsung OLED. The dual-source luminance factors for the LG and Samsung OLED displays were 0.00128 and 0.309, respectively. This rather large value for the Samsung OLED display arises from the wide matrix scatter.

### Large-Source Specular Reflection

The IDMS § 11.7.3 Large-Source Specular Reflection requires that the source and detector be placed  $\pm 15^\circ$  on each side of the normal. We used  $\pm 30^\circ$  for ease of apparatus configuration. The source had a subtense of  $15^\circ$  and was identical to the source used on the right side of the dual-source measurement (see Fig. 8). This type of measurement in the specular direction includes not only the true specular component, but also any haze or matrix scatter in the vicinity of the true specular component. As such, it is not a true

Fig. 5: Ring-light geometry and views from the detector position appear with the LG OLED on the left and the Samsung OLED on the right. The inset picture shows the view through the spectroradiometer eyepiece.

measurement of the specular component of reflection whenever non-trivial haze or matrix scatter is present. A high-resolution (approximately 0.2°) BRDF apparatus can resolve the

specular component from the other components of reflection, but in this large-source measurement they are lumped together. Accordingly, the symbol  $\zeta$  is used instead of

$\rho_s$  for this type of specular measurement. The lumped specular reflectance for the LG OLED and Samsung OLED displays were 0.0224 and 0.0218, respectively. To keep this in perspective, a single untreated glass surface specular reflectance is approximately 0.045; so these displays are doing quite well by comparison.

### BRDF Measurements

Specifications on how to make BRDF measurements are not included in the IDMS; more research was needed at the time of its compilation. The apparatus employed here had a medium resolution of 0.6° and a specular configuration angle of 3°. It used a converging source (white LED) and a quasi-photopic detector.<sup>6</sup> The source iris was approximately 1 mm in diameter and was focused onto the detector iris of 6.3 mm in diameter. (The source had a beam diameter of 48 mm and a 300-mm focal-length lens resulting in a focal ratio of  $f/6.3$ .) We only provided the horizontal in-plane BRDF from 3° away from the display normal out to 70°. The source was fixed at -3° relative to the display normal and the detector was rotated about the display center. The source incident flux was determined by placing a calibrated RG-1000 black

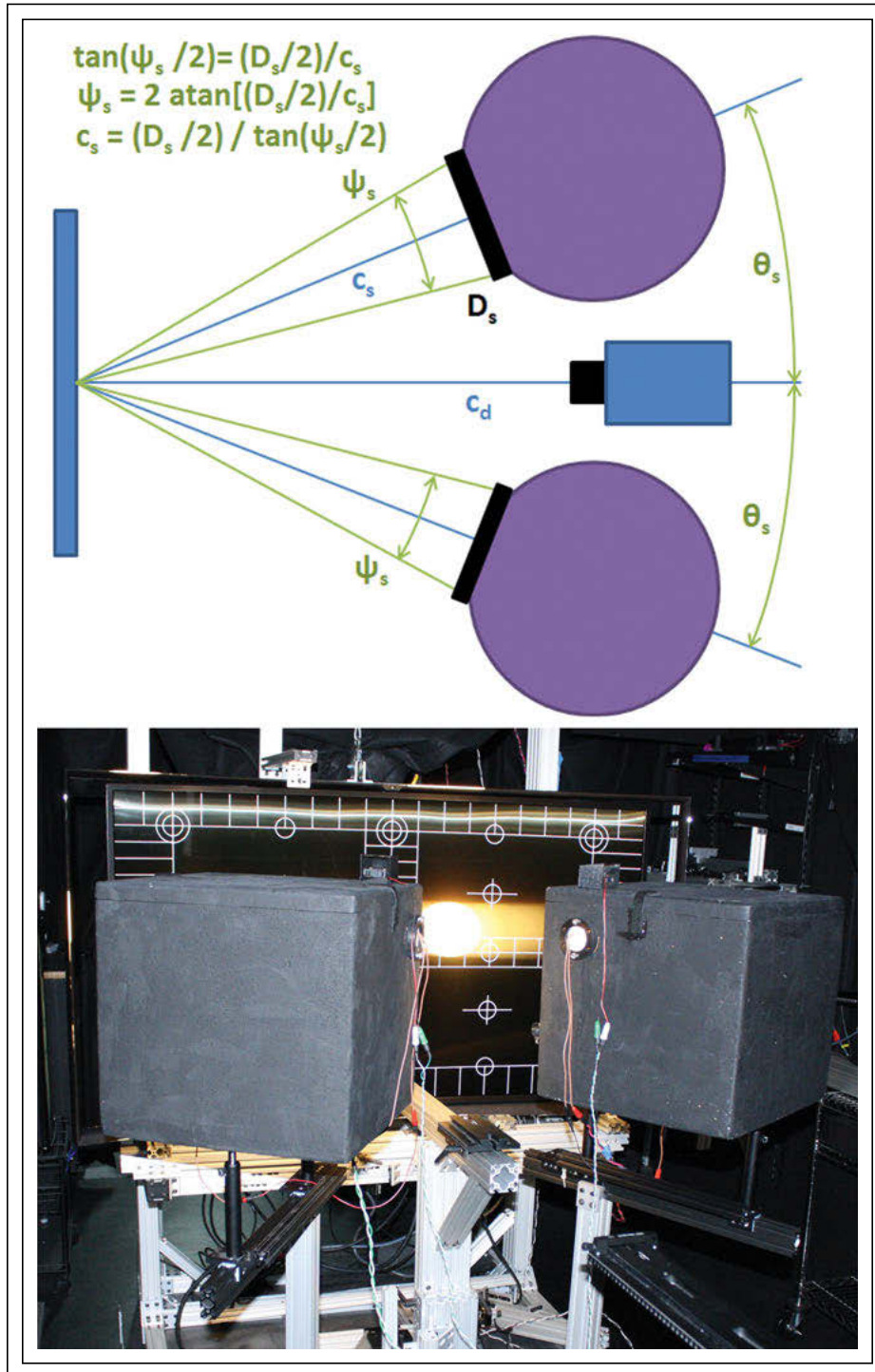

Fig. 6: Dual sources placed at  $\pm 30^\circ$  have subtenses of  $15^\circ$ . The alignment pattern is shown.

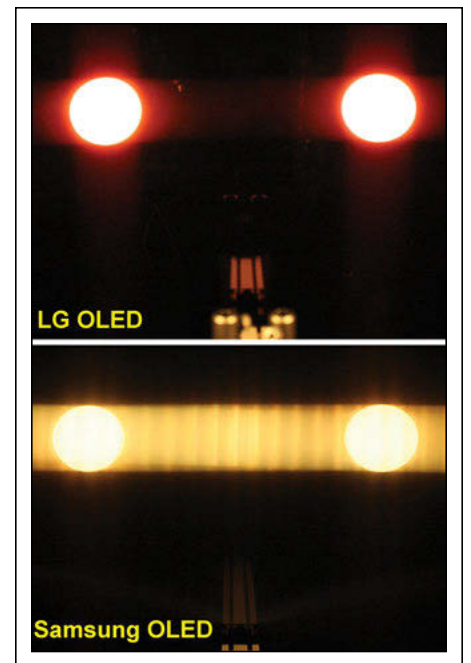

Fig. 7: Here, the reflection from the dual sources is viewed from the normal.

glass near the screen and repositioning the detector for the displacement from the display surface at the  $\pm 3^\circ$  configuration. The

resulting BRDF profiles illustrate the matrix scatter, especially in the Samsung OLED (see Fig. 9).

**A Need for New Measurements**  
Because we observed a darkening of the OLEDs in the Samsung display when it was

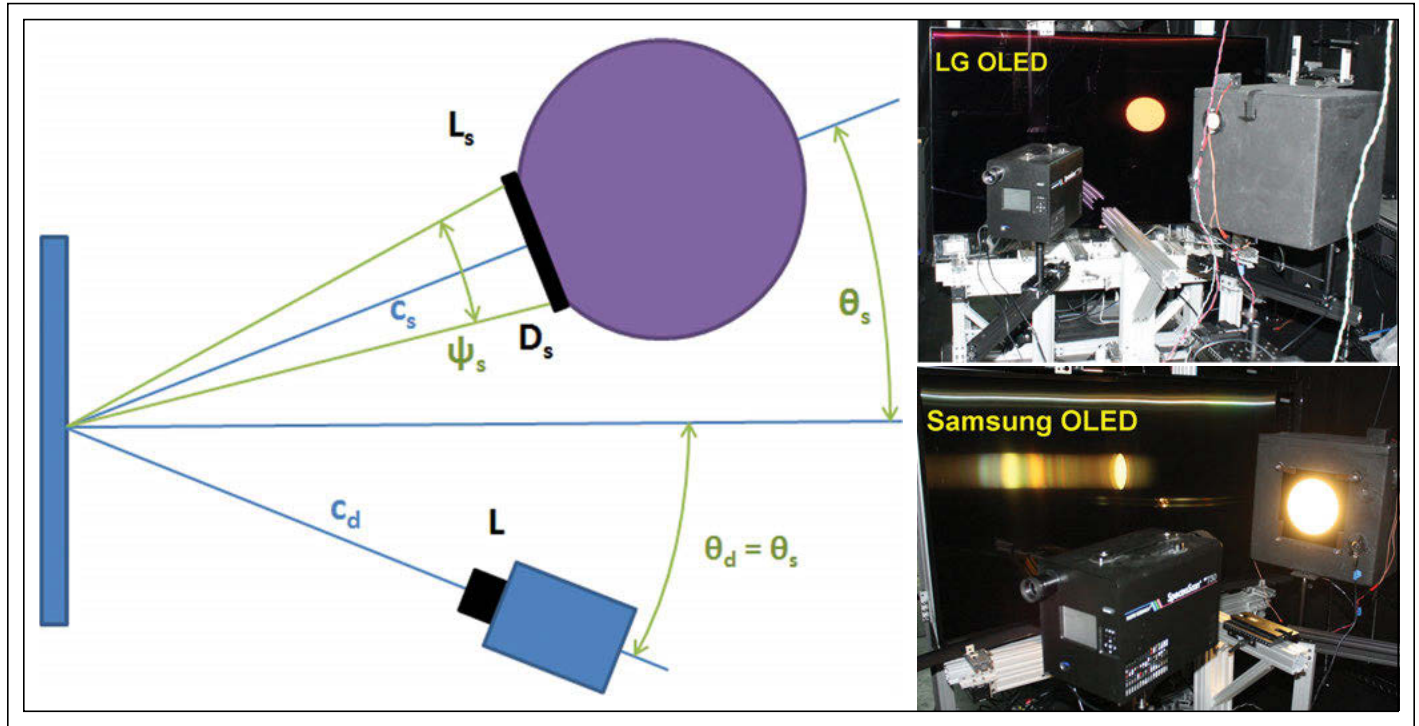

Fig. 8: These images show large-uniform-source reflection measurement in the specular direction. In the picture on the bottom right, the source and detector are turned to face each other to measure the source luminance (radiance).

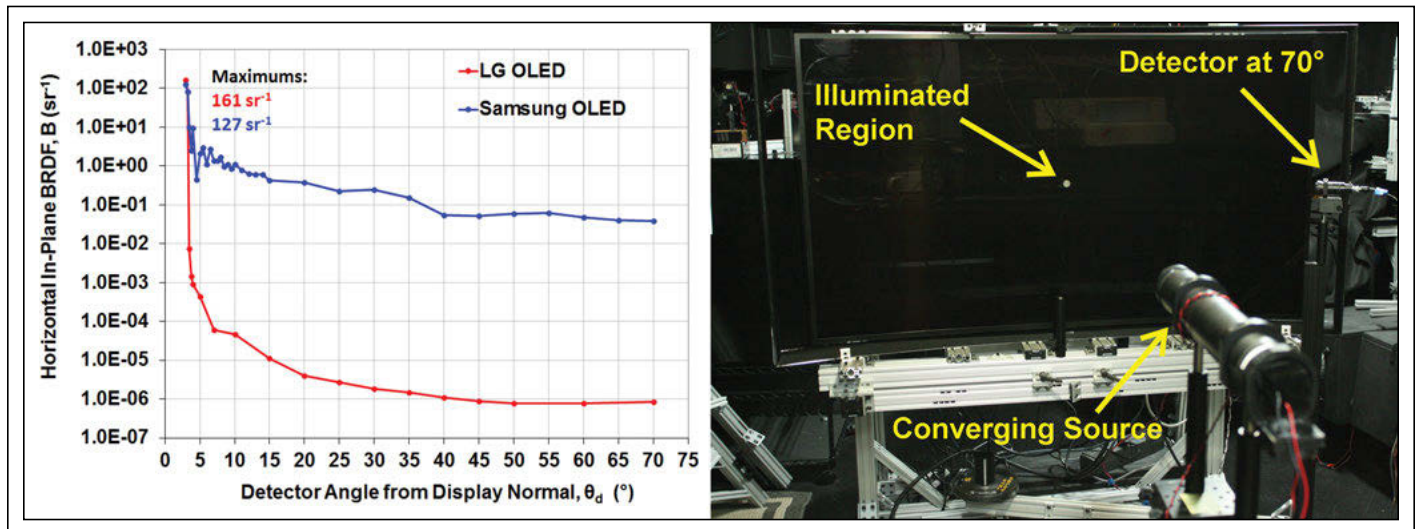

Fig. 9: BRDF results for both OLED displays appear in the graph at left. The photograph on the right shows the BRDF measurement configuration with the detector at  $70^\circ$  from the display normal. The 48-mm-diameter converging source is  $3^\circ$  to the left of normal and illuminates a small region on the display. The detector measures the specular component when at  $3^\circ$  to the right of the display normal and the scattered light at angles greater than  $3^\circ$  away from the normal.

subjected to very large illuminances, the assumption of linearity and superposition in reflection measurements may not always be true. Linear superposition was a fundamental assumption in the reflection chapter of the IDMS (see 11.1.1). This singular darkening result will require a complete reconsideration of the material in Chapter 11 on reflection in the IDMS document and especially the section on ambient contrast, § 11.9. We did not imagine this would ever happen! Understand that this darkening observation is not a criticism of the Samsung display; it just means that we have encountered a new property in the measurement of reflections that was not previously anticipated. We will have to document a procedure to detect such a property and invent a procedure to make such reflection measurements on non-black patterns in the future.

We have seen how the LG OLED display has benefitted from an anti-reflection front surface and good control of matrix scatter. These results also show that the Samsung OLED has a very wide matrix scatter distribution without any anti-reflection treatment; the matrix scatter especially interferes with good control of reflection properties, particularly for isolated sources in the surround that can create a band of reflected light in the display.

While these are beautiful displays that have zero-luminance blacks, reflections from the room reduce the available contrast because of

adding light to those wonderful blacks. Thus, in one simulation we found contrasts from 400 in the Samsung OLED to 1058 in the LG OLED coming from illumination conditions for a living room. However, these contrasts are better than displays that exhibit a non-zero black where the resulting contrasts would be even less for the same living-room environment: For example, a display with a white luminance  $L_W = 400 \text{ cd/m}^2$  and a black luminance  $L_K = 1 \text{ cd/m}^2$  (giving a darkroom contrast of 400:1) having the same reflection properties as the LG OLED would exhibit a contrast of  $C_A' = 290$  for those same living-room conditions where the LG OLED exhibited a contrast of  $C_A' = 1058$ . These OLED displays may well present a better overall image appearance than others under moderate-to-high ambient conditions because of their absolute blacks, but for best viewing experience we will enjoy them most in a very dark theater environment.

#### References

<sup>1</sup>E. F. Kelley, "Considering Color Performance in Curved OLED TVs," *Information Display* **29**, No. 6, 13 (2013).

<sup>2</sup>This work was partially funded by LG Display Co., Ltd. Their contribution to our effort is again gratefully acknowledged.

<sup>3</sup>M. E. Becker, "Display reflectance: Basics, measurement, and rating," *J. Soc. Info. Display*

14, 1003–1017 (doi: 10.1889/1.2393025) (2006).

<sup>4</sup>As in the previous article, we make repeated reference to the Information Display Measurements Standard (IDMS), prepared by the International Display Metrology Committee of the Society of Information display. The PDF version is available without charge; see <http://icdm-sid.org/>.

<sup>5</sup>Disclaimer: The apparatus pictured or described herein are identified only for the purpose of complete technical description: The signals are provided from a computer using an NVIDIA GeForce GTX 570 board with an HDMI (high-definition multimedia interface) output. The signal output quality is checked using computer monitors to assure that what is delivered to the TVs is correct without artifacts. The spectroradiometric measurements are made with a Photo Research PR-730 spectroradiometer. All measurements are made in a quality darkroom.

<sup>6</sup>See, ASTM Standards on Color and Appearance Measurement, 6th ed., E 167-96, "Standard Practice for Goniophotometry of Objects and Materials," pp. 264–267 (2000) (withdrawn 2005). Also, see E 2387 – 05, "Standard Practice for Goniometric Optical Scatter Measurements," in the 8th ed. ■

Same tough glass.  
Now  
**Tough**  
on bacteria.

Introducing the world's first antimicrobial cover glass.  
Antimicrobial Corning® Gorilla® Glass

Learn more at SID Display Week 2014 | Booth 703  
Visit [CorningGorillaGlass.com](http://CorningGorillaGlass.com)

*Antimicrobial Corning® Gorilla® Glass is formulated with antimicrobial properties to protect touch surfaces from odor and stain causing bacteria. Corning makes no direct or implied claims to protecting users or providing other health benefits.*



# The Future Is Paper Based

*Paper may be the key to an entirely new class of inexpensive flexible electronics, including displays.*

by Rodrigo Martins, Luis Pereira, and Elvira Fortunato

**P**RINTED-PAPER ELECTRONICS, with their promise of low cost, flexibility, and full recyclability are attracting more and more interest among product developers. The paper industry today is facing challenges from electronic books and journals. At the same time, the packaging industry is working to develop packaging that can interact with end users. The former is challenged to find alternative sources of revenue and the latter to expand product capabilities. Thus, we are observing a number of companies that are developing paper not only as a surface on which to print ink but also as a surface for electronics. The end result may be a plethora of low-cost disposable and recyclable products.

Examples of current paper-electronics developments from paper and packaging companies include Portucel (Portugal),<sup>1</sup> which is developing new types of paper for a broad range of applications, including transparent

paper; Felix Scholler (Germany),<sup>2</sup> now developing paper for printing electronics as part of a next-generation sustainable paper project based in Europe called A3ple<sup>3</sup>; Suzano (Brazil),<sup>4</sup> which is now researching and developing new papers for electronics applications; and Stora Enso (Finland),<sup>5</sup> currently developing new smart packaging. In Korea, there is also a growing interest in promoting the use of the traditional bark-based Hanji paper for other purposes, including electronics.

Indeed, electronic products printed on paper could transform labelling, packaging, and publishing as we know them today, to mention just a few examples. Applications might include intelligent packaging, richer security documents, and inexpensive and flexible

diagnostic products for the medical and pharmaceutical industries. Imagine a sheet of newspaper in the form of a rollable and foldable display, which can store information in memory and could incorporate a self-powered energy unit. The paper of the future could serve as a functionalized electronic component with which we can fabricate our own ergonomic and disposable green phones and products such as lighting woven into paper pulp, cardboard that folds into a box at the touch of a finger, or a paper sheet on which we can play a movie.

In addition, paper is one of the cheapest and most commonly used materials in our society. Cellulose, on which paper is based, is the Earth's major biopolymer and is of tremen-

*Rodrigo Martins is President of the European Materials Research Society and Full Professor at Universidade Nova de Lisboa and the Director of the Centre of Excellence in Microelectronics and Optoelectronic Processes (CEMOP) of the Uninova Institute, Campus de Caparica in Portugal. He can be reached at [rm@uninova.pt](mailto:rm@uninova.pt). Luis Pereira is a Senior Researcher of CEMOP and of CENIMAT/I3N and can be reached at [lmnp@fct.unl.pt](mailto:lmnp@fct.unl.pt).*

*Elvira Fortunato is Coordinator of CENIMAT/I3N and the Director of I3N and Full Professor at Universidade Nova de Lisboa, Campus de Caparica in Portugal. She can be reached at [emf@fct.unl.pt](mailto:emf@fct.unl.pt).*

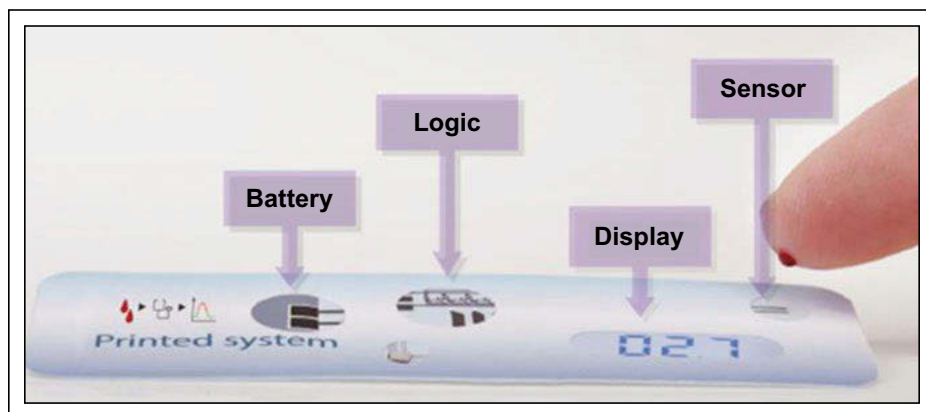

**Fig. 1:** Paper is the substrate for this smart system that incorporates a printed display. This concept shows how different materials can be printed to integrate different devices, such as a battery, a biosensor, a display, and electronic circuits in the same paper substrate to build a self-sustained bio-detection system. Adapted from [blogs.rsc.org](http://blogs.rsc.org).

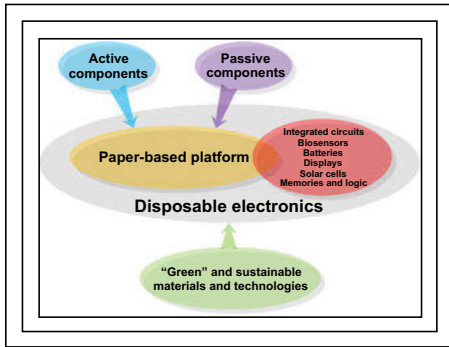

**Fig. 2:** A novel paper-based platform for electronics includes ICs, batteries, and displays.

dous global economic importance, especially in Europe, which is responsible for 30% of the world's total production. Paper is also recyclable and so paper-based electronics will help reduce the environmental impact of "electronic trash."

Some promising paper-based applications have already been demonstrated, including solar cells, displays, capacitors, actuators, gas

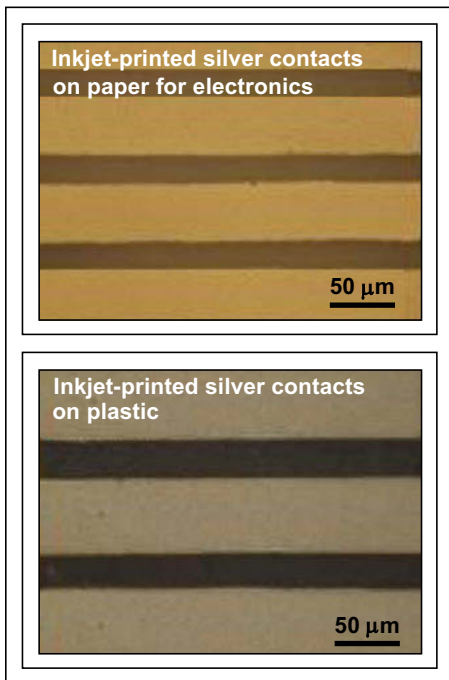
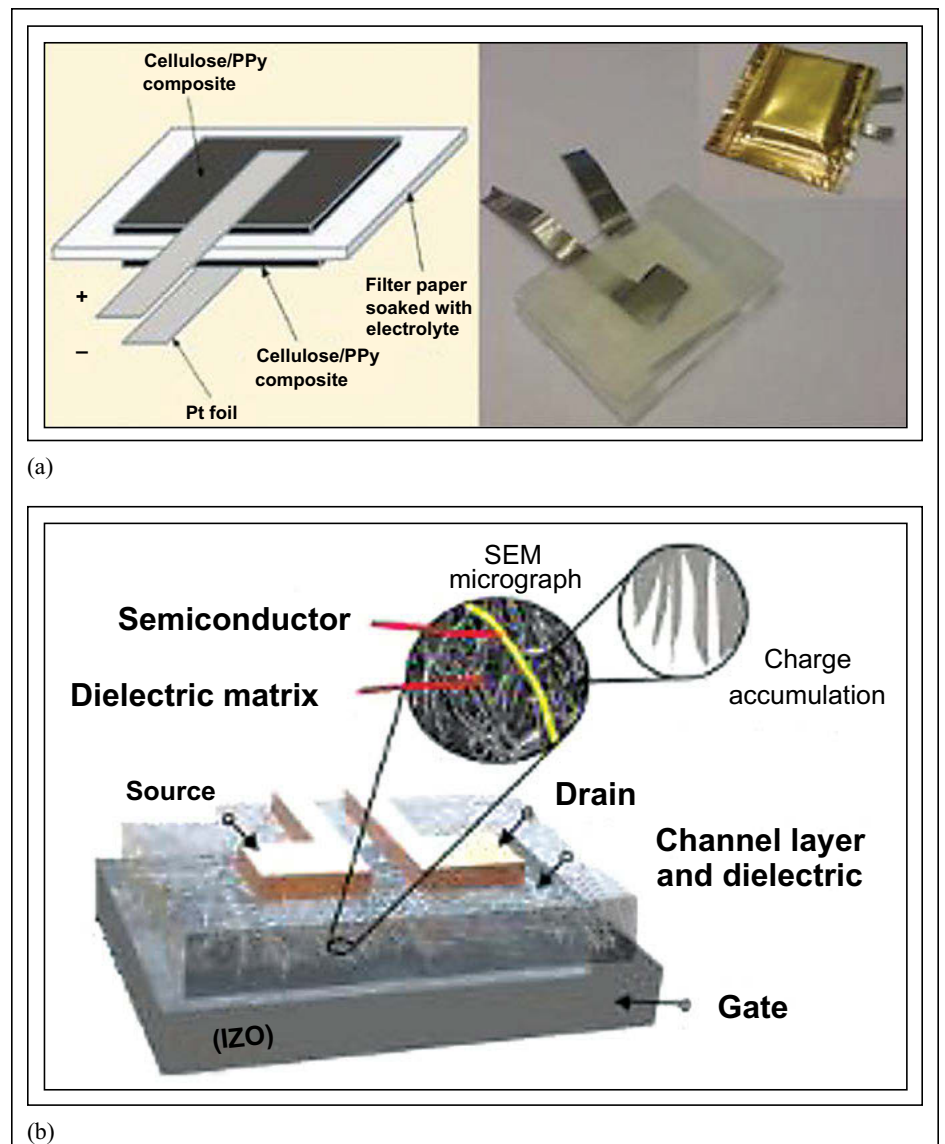

**Fig. 3:** Ink-jet-printed silver contacts on paper (top) and polymer (bottom) show that scalability and resolution are similar for both types of substrates when printing is used to process conductive lines.

sensors, magnetic devices, and batteries.<sup>6</sup> In all of these applications, however, the paper has a passive function since it is used as a substrate (Fig. 1). It does not take an active role in the device's working principle. What we are now proposing, in order to achieve the above-mentioned applications, are new disruptive and sustainable paper-based platforms for electronics that not only integrate discrete devices but also use the cellulose as an electronic material for insulators, electrolytes, conductors, and semiconductors. Such a platform is outlined in Fig. 2.

### Key Materials and Processes

The benefits of paper-based electronic devices and systems were highlighted in the previous section. Achieving these devices imposes some challenges with regard to the necessary materials and processes. One of the first steps toward the use of paper for electronics is to see how conductor lines behave on paper<sup>7</sup> when compared to other polymer-based substrates. This has been shown to be possible with nice downward scalability (below 50 μm), as depicted in Fig. 3.



**Fig. 4:** Image (a) shows a schematic and photo of a paper-based battery.<sup>8,9</sup> Image (b) is a schematic of a paper-based memory device based on a floating gate TFT.<sup>10</sup>

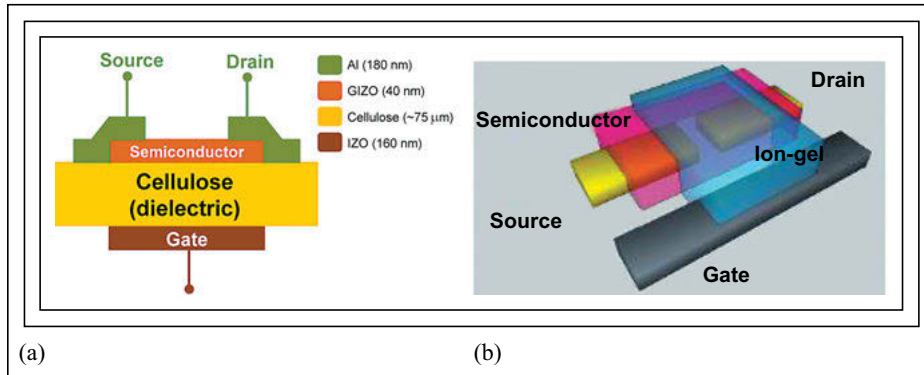

Fig. 5: A paper-based inorganic TFT<sup>11</sup> schematic appears in (a); image (b) depicts a design for an organic TFT on paper.<sup>15</sup>

Paper itself can also be used as an active part on some devices. The proof of concept of using paper as an electrolyte has been explored, mainly for battery<sup>8,9</sup> and memory<sup>10</sup> applications (Fig. 4). The use of paper as a dielectric in producing thin-film transistors (TFTs) has been also demonstrated, using inorganic<sup>11–14</sup> or organic<sup>15</sup> based functionalized materials. In the first case, the paper is sandwiched between the gate electrode on one side. The channel, with the corresponding drain and source, is placed on the other side of the paper sheet. In the second case, the transistor is organic based and is implanted in an electrolyte gel foil (Fig. 5).

These developments, and the ability to make n- and p-type TFTs on paper,<sup>16</sup> open the possibility of integrating paper-based TFTs as a core component to build up complementary metal oxide semiconductors (CMOS),<sup>17</sup> themselves core components for low-power-consumption analog and digital circuits. This, in turn, opens the door to new applications ranging from smart labels and sensors on clothing and packaging to electronic displays printed on paper pages for use in newspapers, magazines, books, signs, and advertising billboards.

The holistic approach of merging low-power circuitry with a recyclable substrate

poses an important step toward greener electronics. The proof of concept developed by our research group, in close cooperation with Professor Arokia Nathan and his group from Cambridge University, UK, shows the possibility of processing CMOS-based electronics (at almost macroscopic scale) with reasonable gains and the ability to scale down either by printing or by using soft patterning techniques (Fig. 6).

We can therefore predict the use of these devices as amplifiers, with a common source and differential structure, or integrated as logic gates, such as NOR or NAND gates (Fig. 7).

As far as digital circuits are concerned, we have recently proven the concept<sup>18</sup> of creating a variety of simple analog and digital circuit devices such as inverters and flip-flops on paper. These are the building blocks for larger scale circuits such as multiplexers, shift registers, ring oscillators, and others.

Another relevant issue concerns a recent demonstration of the possibility of producing p-n based cellulose made of two oppositely charged microfibrillated cellulose (also known as nanocellulose) sublayers<sup>19</sup> (Fig. 8). The current rectification ratio is around 15 at  $\pm 5$  V and exhibits good repeatability at room temperature. Instead of forming a depletion region to rectify current, this paper diode uses asymmetric charge distribution to selectively control the ion-diffusion direction. The asymmetric charge distribution inside the diode paper can selectively transport cations and anions under positive and negative bias, to allow an electric current to pass in one direction while being blocked in the opposite direction. Although the mechanism is quite different from that of a semiconductor-based p-n junction, the phenomenon turns out to be very similar.

### Paper-Based Biosensors and Displays

Based on the above examples, we can clearly envision a new type of technology in which the breakthrough idea is to use the same paper substrate that supports the electronics to also drive a bioplatfrom or a display, process source video data, or provide the power source through an embedded chemical battery.

In the case of the bioplatfrom, this is an application of interest to the biomedical industry. Paper is a strong candidate for fully recyclable and low-cost bio diagnostic platforms that would be readily available to all. The concept

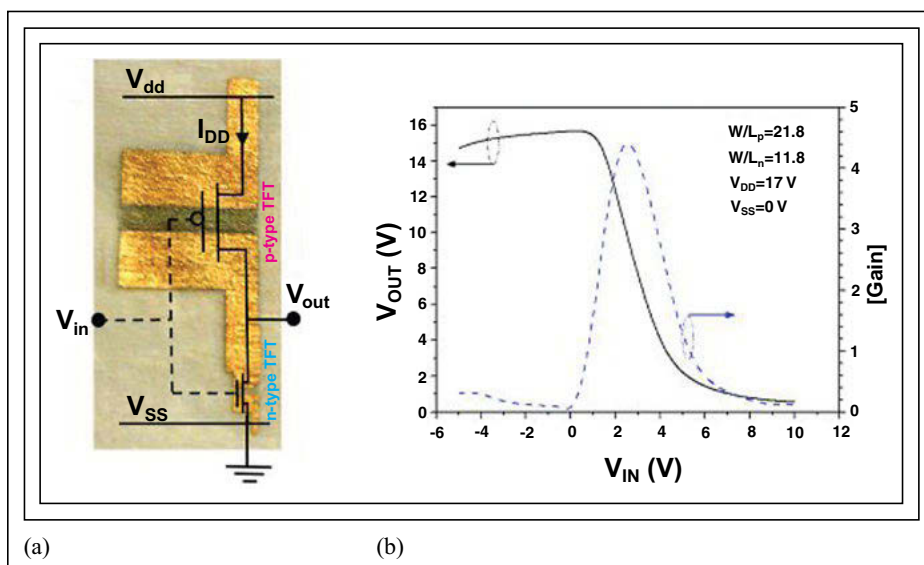

Fig. 6: An image of the configuration of the CMOS inverter on paper (a) appears next to a chart (b) showing its transfer characteristics and gain.



has been proved for the detection of tuberculous mycobacteria nucleic acids<sup>20</sup> and glucose and anti-Leishmania antibodies.<sup>21</sup>

As far as building complete displays, electrochromic displays can now be printed on paper, and a method for an active matrix has been shown by ACREO<sup>22</sup> that is an appropriate solution for paper-based devices – to display the reading of a sensor, for instance – where a fast response time is not a mandatory issue. However, these displays still make use

of some plastic films. Paper can be used to replace these plastic films, using self-standing nanofibrillated cellulose-based films with good transparency, based on the fiber’s diameter, and interesting moisture-barrier properties. The nanocellulose films could be coated with silver nanowires to be used as the top electrode for OLED displays. Moreover, we can, in the near future, make semiconductors with the paper by embedding nanoparticles in it during the paper fabrication process.

So, in the next decade we predict that we will witness the emergence of paper-based flexible displays with integrated driving circuits, disposable sensors for medical applications, fast environmental sensors, sensors with RFID for radio-wave readouts, smart information labels, electronic marketing products, games, flexible solar cells, low-cost memory chips and printed batteries, and more. This will open a new era not only for paper, but also for electronics,

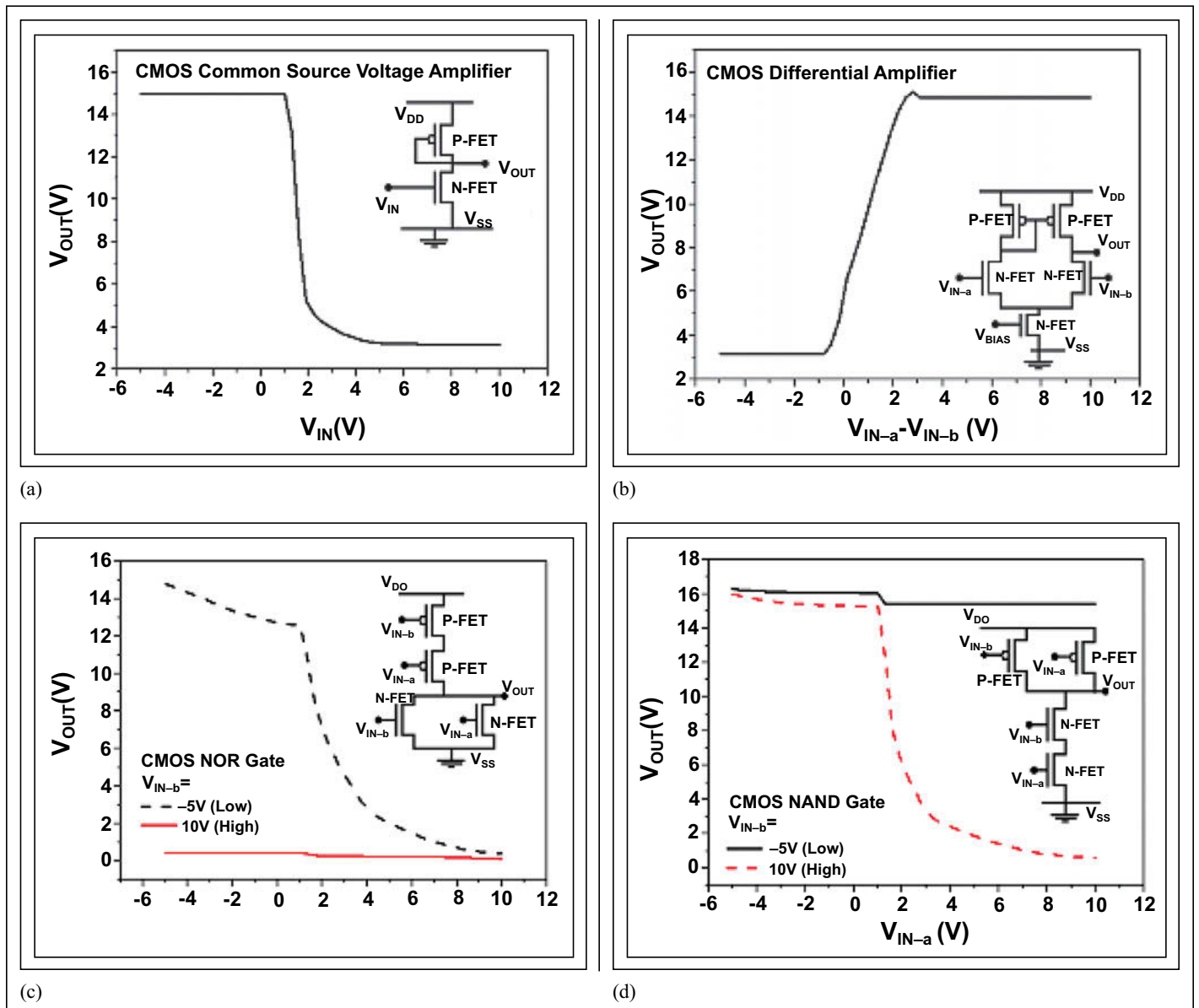
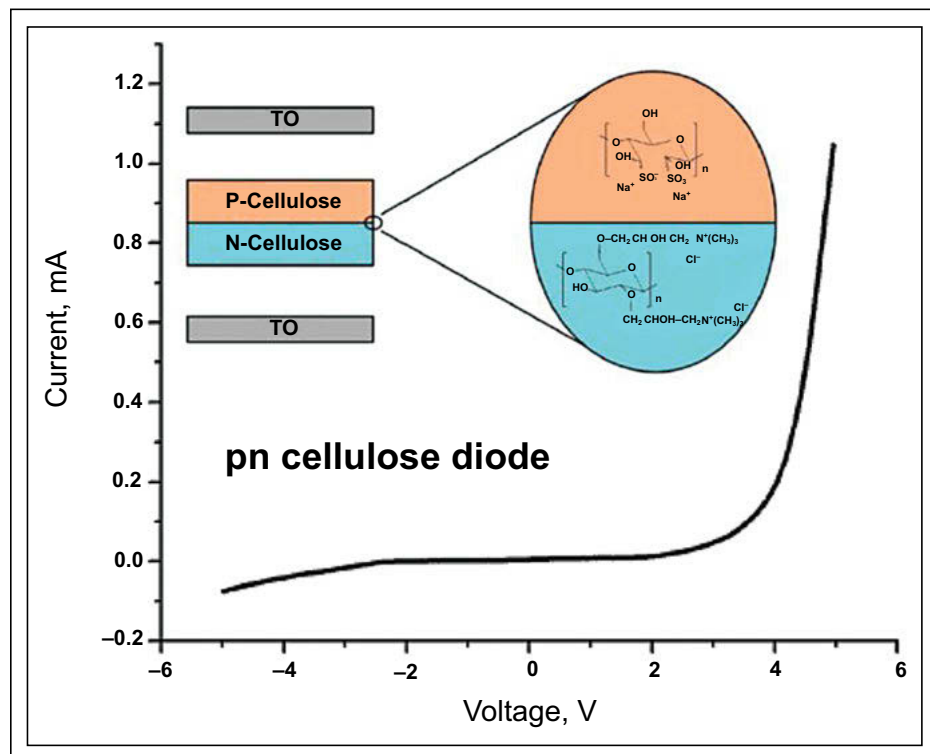

Fig. 7: The above charts depict circuits for electronics on paper including (a) common source amplifier, (b) differential amplifier, (c) NOR gate, and (d) NAND gate.



**Fig. 8:** This chart depicts an *I-V* curve of a *pn* junction based on functionalized and doped fibers, all embedded on paper.<sup>19</sup>

**References**

<sup>1</sup><http://www.portucelsoporcel.com/pt/group/novos/investigacao.html>  
<sup>2</sup>[http://www.felix-schoeller.com/de\\_de/home.html](http://www.felix-schoeller.com/de_de/home.html)  
<sup>3</sup><http://www.a3ple.eu>, APPLE (FP7-NMP-2010-SME/262782-2)  
<sup>4</sup><http://ri.suzano.com.br/?language=ptb>  
<sup>5</sup><http://www.storaenso.com/>  
<sup>6</sup><https://www.aceo.se/>  
<sup>7</sup>D. Tobjörk, H. Aarnio, P. Pulkkinen, R. Bollström, A. Määttänen, P. Ihalainen, T. Mäkelä, J. Peltonen, M. Toivakka, H. Tenhu, and R. Österbacka, “IR-sintering of ink-jet-printed metal-nanoparticles on paper,” *Thin Solid Films* **520**, 2949–2955 (2012).  
<sup>8</sup>L. Nyholm, G. Nystrom, A. Mihranyan, and M. Stromme, “Toward Flexible Polymer and Paper-Based Energy Storage Devices,” *Adv. Mater.* **23**, 3751–3769 (Sept. 2011).  
<sup>9</sup>I. Ferreira, B. Bras, J. I. Martins, N. Correia, P. Barquinha, E. Fortunato, and R. Martins, “Solid-state paper batteries for controlling paper transistors,” *El. Chem. Act.* **56**, 1099–1105 (2011).

<sup>10</sup>R. Martins, P. Barquinha, L. Pereira, N. Correia, G. Goncalves, I. Ferreira, and E. Fortunato, “Write-erase and read paper memory transistor,” *Appl. Phys. Lett.* **93**, 203501–203503 (2008).  
<sup>11</sup>E. Fortunato, N. Correia, P. Barquinha, L. Pereira, G. Goncalves, and R. Martins, “High-performance flexible hybrid field-effect transistors based on cellulose fiber paper,” *IEEE Electron Dev. Lett.* **29**, 988–990.  
<sup>12</sup>E. Fortunato and R. Martins, “Where science fiction meets reality? With oxide semiconductors!,” *Phys. Stat. Sol. – Rapid Research Letters* **5** (9), 336–339 (Sept. 2011).  
<sup>13</sup>L. Pereira, D. Gaspar, D. Guerin, A. Delattre, E. Fortunato, and R. Martins, “The influence of fibril composition and dimension on the performance of paper gated oxide transistors,” *Nanotechnology* **25**, 094007 (2014); doi: 10.1088/0957-4484/25/9/094007  
<sup>14</sup>D. Gaspar, S. N. Fernandes, A. G. de Oliveira, J. G. Fernandes, P. Grey, R. V. Pontes, L. Pereira, R. Martins, M. H. Godinho, and E. Fortunato, “Nanocrystalline cellulose applied simultaneously as the gate dielectric and the substrate in

flexible field effect transistors,” *Nanotechnology* **25**, 094008, 11 (2014); doi:10.1088/0957-4484/25/9/094008

<sup>15</sup>D. Tobjork *et al.* Group.  
<sup>16</sup>R. Martins, I. Ferreira, E. Fortunato, “Electronics with and on paper,” *Phys. St. Sol. – Rapid Research Lett.* **5**, No.9, 332–335 (Sept. 2011).  
<sup>17</sup>R. Martins, A. Nathan, R. Barros, L. Pereira, P. Barquinha, N. Correia, R. Costa, A. Ahnood, I. Ferreira, and E. Fortunato, “Complementary Metal Oxide Semiconductor Technology with and On Paper,” *Adv. Mater.* **23**, 4491 (2011).  
<sup>18</sup>R. Martins A. Ahnood, N. Correia, L. Pereira, R. Barros, P. Barquinha, R. Costa, I. Ferreira, A. Nathan, and E. Fortunato, “Recyclable, Flexible, Low-Power Oxide Electronics,” *Adv. Funct. Mat.* (2013); doi 10.1002/adfm.201202907.  
<sup>19</sup>W. Zhang, X. D. Zhang, C. H. Lu, Y. J. Wang, and Y. L. Deng, “Flexible and Transparent Paper-Based Ionic Diode Fabricated from Oppositely Charged Microfibrillated Cellulose,” *J. Phys. Chem. C* **116**, 9227–9234 (Apr. 2012).  
<sup>20</sup>M. N. Costa, B. Veigas, J. M. Jacob, D. S. Santos, J. Gomes, P. V. Baptista, R. Martins, J. Inácio, and E. Fortunato, “A low cost, safe, disposable, rapid and self-sustainable paper-based platform for diagnostic testing: lab-on-paper,” *Nanotechnology* **25**, 094006, 12 (2014); doi:10.1088/0957-4484/25/9/094006.  
<sup>21</sup>B. Veigas, J. M. Jacob, M. N. Costa, D. S. Santos, M. Viveiros, J. Inacio, R. Martins, P. Barquinha, E. Fortunato, and P. V. Baptista, “Gold on paper-paper platform for Au-nanoprobe TB detection, LAB ON A CHIP **12** (22), 4802–4808 (2012); doi: 10.1039/c2lc40739f.  
<sup>22</sup>P. Andersson, D. Nilson, P.-O. Svensson, M. Chen, A. Malmstrom, T. Remonen, T. Kugler, and M. Berggren, “Active Matrix Displays Based on Al-Organic Electrochemical Smart Pixels Printed on Paper,” *Adv. Mater.* **14**, 1460–1464 (2002). ■

# Information DISPLAY

**SID**  
SOCIETY FOR INFORMATION DISPLAY

Official Monthly Publication of the Society for Information Display



## LINKING BUYERS AND SUPPLIERS

For all print and online advertising inquiries, please contact:  
Roland Espinosa, Information Display, Wiley  
respinosa@wiley.com • 201-748-6819

[informationdisplay.org](http://informationdisplay.org)

# Flat-Panel-Display Backplanes: LTPS or IGZO for AMLCDs or AMOLED Displays?

*After more than 20 years as the flat-panel-display backplane TFT material of choice, a-Si:H is running out of steam. The two contending replacement options are LTPS and IGZO. Which is better and how does this material choice impact the race between AMLCD and AMOLED-display front-plane technologies?*

by John F. Wager

UNTIL RECENTLY, it was obvious that low-temperature polysilicon (LTPS) would eventually replace hydrogenated amorphous silicon (a-Si:H) as the thin-film-transistor (TFT) channel layer material for display backplane switching applications. After all, silicon always wins. Just ask the gallium arsenide integrated-circuit guys. Then the upstart indium gallium zinc oxide (IGZO) appeared on the scene. What's going on here?

## Amorphous Oxide Semiconductors

IGZO is one example of a relatively new class of materials, amorphous oxide semiconductors (AOSs).<sup>1-4</sup> AOSs were originally formulated for transparent-conductive-oxide (TCO) applications. Now they are being considered for TFT channel layers and other applications.

The key to appreciating the desirable attributes of an AOS is to understand how it is designed. Hosono *et al.* proposed that the design of an AOS involves (i) forming an oxide using multiple cations and (ii) selecting these cations from the portion of the periodic table shown in Fig. 1.<sup>5</sup> Multiple cations are employed in AOS designs because simple binary oxides, *e.g.*, ZnO, SnO<sub>2</sub>, and In<sub>2</sub>O<sub>3</sub>,

have a strong tendency to crystallize. In contrast, the use of multiple cations confuses the lattice with respect to which microstructure it should adopt, thereby frustrating crystallization. Moreover, cations that are selected from the portion of the periodic table shown in Fig. 1 possess conduction bands that are derived from large-ionic-radius spherically symmetric 4s, 5s, or 6s electron orbitals.<sup>5</sup> This means that an electron can readily move from one orbital to another, rapidly propagating through the material. In other words, the nature of these orbitals means that an AOS is expected to have a relatively high electron mobility compared to that of a-Si:H (see Table 1), independent of whether the microstructure is crystalline or amorphous.

In addition to high electron mobility, a commercially viable TFT channel semiconductor must provide favorable characteristics for integration into a robust and cost-effective semiconductor manufacturing process. Although other AOS compositions are potentially useful for display backplane applications, IGZO offers a compelling combination of performance and process attributes and is the AOS leader in early commercialization. Thus, our subsequent AOS discussion focuses exclusively on IGZO.

In summary, IGZO is amorphous, like a-Si:H, but has a superior electron mobility compared to that of a-Si:H.

## AMLCD Backplanes: Performance or Cost?

The architecture of an AMLCD backplane pixel is very simple, consisting of a single voltage-controlled switch, usually a TFT. Three AMLCD TFT technology options – a-Si:H, LTPS, and IGZO – are compared in Table 1.

Since AMLCDs were commercially introduced in around 1990, a-Si:H has until now been the AMLCD backplane TFT champion. a-Si:H was selected for AMLCD applications because it had adequate performance, process simplicity, the lowest cost, and could be readily scaled to large-area meter-sized dimensions. Three a-Si:H advantages highlighted

11	12	13	14	15	
29 Cu 63.54	30 Zn 65.37	31 Ga 69.72	32 Ge 72.59	33 As 74.92	4
47 Ag 107.87	48 Cd 112.40	49 In 114.82	50 Sn 118.69	51 Sb 121.75	5
79 Au 196.97	80 Hg 200.59	81 Tl 204.37	82 Pb 207.19	83 Bi 208.98	6

*Fig. 1: This portion of the periodic table was identified by Hosono *et al.*<sup>5</sup> for selecting amorphous-oxide semiconductor cations.*

*John F. Wager holds the Michael and Judith Gaulke Endowed Chair in the School of EECS at Oregon State University. He can be reached at [jfw@eeecs.oregonstate.edu](mailto:jfw@eeecs.oregonstate.edu).*

in Table 1 – threshold-voltage ( $V_T$ ) uniformity, mobility uniformity, and process complexity – are direct consequences of the amorphous nature of a-Si:H. Of the three a-Si:H liabilities included in Table 1 – poor stability, poor mobility, and NMOS – mobility is the most important consideration likely to inhibit the use of a-Si:H for upcoming AMLCD commercial applications because that mobility is inadequate for the higher anticipated refresh rates required for future products and limits the ability to reduce TFT size, as needed for small pixels in high-resolution mobile displays.

After the mobility of a-Si:H was recently determined to be a limiting factor, LTPS was considered the obvious a-Si:H replacement. With respect to mobility, LTPS is the clear winner in Table 1. Additionally, LTPS TFTs have much better stability than a-Si:H TFTs. Finally, the availability of complementary metal-oxide-semiconductor (CMOS) TFTs using LTPS means that row and column drivers, for example, or other peripheral circuits can be integrated onto the glass substrate.

In a word, the LTPS advantage is *performance*.

In contrast, since p-channel TFTs are not available using IGZO, CMOS is not possible. Also, the electron mobility of IGZO is less than that of LTPS. However, IGZO is amorphous. Thus, it possesses the same manufacturing/scaling/cost advantages as a-Si:H with respect to threshold-voltage uniformity and mobility uniformity. Additionally, as is the case for a-Si:H, IGZO processing is simple. In fact, IGZO source/drain contacts can be

formed directly by simply patterning the contact metal (or TCO) directly onto an IGZO channel layer. No channel layer contact doping or deposition of an additional doped contact layer between source/drain and active channel is required, as is the case for a-Si:H and LTPS. This simplifies IGZO processing, potentially eliminating one or more process steps. However, IGZO surfaces tend to be highly sensitive, so development of a back-channel etch process such as that currently used in advanced a-Si:H TFT manufacturing appears to be challenging. First-generation IGZO technology has been implemented using etch-stop processing, thus requiring an extra masking step compared to that of advanced a-Si:H TFT processing, but still fewer than required for an LTPS TFT process.

Additionally – and this is important – since a-Si:H and IGZO process flows are quite similar, it appears that for a relatively modest capital investment, an operating a-Si:H TFT fab can be retrofitted for IGZO by replacing the a-Si:H plasma-enhanced chemical vapor deposition (PECVD) channel layer process with physical vapor deposition (PVD) IGZO and the  $\text{SiN}_x$  PECVD gate dielectric process with PECVD  $\text{SiO}_2$ . This would save money. In contrast, going to LTPS will generally require construction of a new fab rather than retrofit of an existing a-Si:H plant.

In a word, the IGZO advantage is *cost*.

### The Meaning of Performance

Until recently, the LTPS vs. IGZO debate largely boiled down to a discussion of per-

formance vs. cost, as just presented. However, Sharp seems to have confused things a bit with respect to performance.<sup>6</sup> The company's basic argument may be elucidated with the assistance of Fig. 2.

Figure 2 shows an idealized comparison of  $\log(I_D) - V_G$  transfer curves for a-Si:H, IGZO, and LTPS TFTs. As indicated in Fig. 2, increasing mobility and decreasing leakage are two primary transfer-curve considerations that determine the suitability of a TFT for an AMLCD switching application. As mentioned previously, LTPS is the clear winner in terms of mobility (see Table 1), although IGZO offers significant mobility improvement compared to a-Si:H. A higher channel-layer mobility is attractive because TFTs may be reduced in physical size and yet still supply the required current, and the TFT response time will be faster, enabling increased display refresh rates.

Sharp's important contribution to the discussion of TFT performance is to point out that off-state drain-current leakage considerations are also pertinent when evaluating a TFT for its suitability for AMLCD switching. Figure 3 clarifies that there are two primary contributions to off-state drain-current leakage, involving leakage in the channel and/or through the gate insulator.

In terms of off-state drain-current leakage, IGZO is the clear winner. IGZO TFTs have

**Table 1:** Key considerations are compared for a-Si:H, LTPS, and IGZO TFT-AMLCD applications. Color coding: blue = good, red = poor; green = fair.

Property	a-Si:H	LTPS	IGZO
Microstructure	amorphous	polycrystalline	amorphous
$V_T$ uniformity	good	fair <sup>1</sup>	fair <sup>1</sup>
$V_T$ stability	poor	good	fair <sup>1</sup>
Mobility	~ 1 $\text{cm}^2/\text{V-sec}$	~ 50-100 $\text{cm}^2/\text{V-sec}$	~ 10-30 $\text{cm}^2/\text{V-sec}$
Mobility uniformity	good	fair <sup>1</sup>	fair <sup>1</sup>
Device type	NMOS <sup>2</sup>	CMOS <sup>3</sup>	NMOS <sup>2</sup>
Process complexity	low	high	low

<sup>1</sup>These assessments are color-coded red (green) for LTPS (IGZO) since this is a mature (emerging) technology where improvements are not expected (expected).

<sup>2</sup>NMOS = n-channel metal-oxide-semiconductor TFTs

<sup>3</sup>CMOS = complementary metal-oxide-semiconductor TFTs (n- and p-channel)

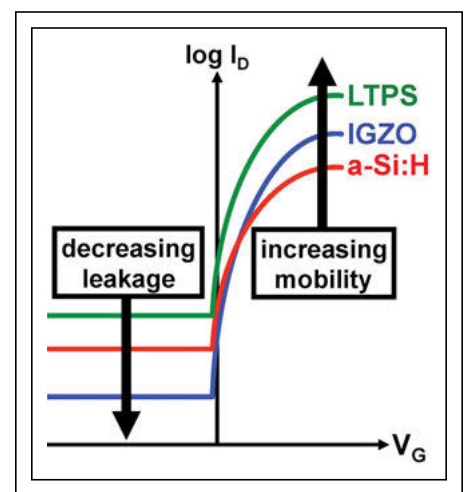

**Fig. 2:** The illustration shown depicts an idealized drain-current or gate-voltage  $[\log(I_D) - V_G]$  transfer-curve comparison of a-Si:H (red), IGZO (blue), and LTPS (green) TFTs.

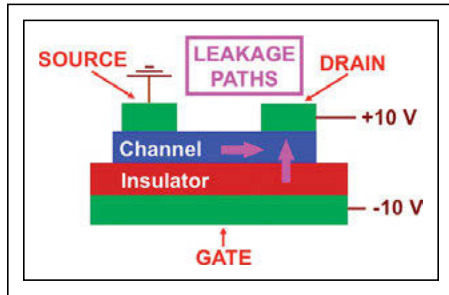

**Fig. 3:** Arrows indicate the directions of electron flux for the primary leakage paths giving rise to the off-state drain-current leakage in a bottom-gate TFT. The horizontal (vertical) arrow corresponds to channel (gate insulator) leakage.

lower leakage across the channel because IGZO is a wide-bandgap [*i.e.*,  $E_G$  (IGZO) = 3.25 eV] unipolar semiconductor. In contrast, LTPS and a-Si:H have significantly narrower bandgaps [*i.e.*,  $E_G$  (LTPS) = 1.1 eV,  $E_G$  (a-Si:H) = 1.7 eV] and are bipolar so that channel inversion occurs at sufficiently large reverse gate bias. Under reverse-bias operation, leakage through the gate insulator may also contribute to the measured off-state drain-current leakage. IGZO TFTs tend to have relatively low gate leakage since they employ a high-quality SiO<sub>2</sub> gate insulator (superior to that of SiN<sub>x</sub> used in a-Si:H TFTs) and they have smooth surfaces so that a uniform electric field develops across the gate insulator/IGZO interface (not the case for LTPS because grains give rise to pronounced roughness at an insulator/LTPS interface). A lower leakage is desirable because less power is dissipated when a TFT is off and the TFT switch can retain an internal pixel charge for a longer period of time so that display refresh rate may be reduced. This leads to reduced power dissipation and in the case of touch-enabled displays, improved touch-screen capability

(due to less noise/interference with touch detection since the display refresh and touch-sensing cycles may be interleaved rather than run simultaneously).

In three words, the *off-current performance* is a key IGZO advantage, largely unappreciated until it was pointed out by Sharp.

**LTPS or IGZO?**

Table 2 highlights the relevant strengths and weaknesses of both LTPS and IGZO technologies. Clearly, if an application requires use of a TFT with an electron mobility higher than that obtainable with IGZO (*i.e.*, ~30 cm<sup>2</sup>/V-sec) and/or CMOS circuit functionality, LTPS is an excellent choice and is, in fact, the only choice. However, those advantages are largely irrelevant for AMLCD backplane applications. Basically, this AMLCD application requires the availability of an inexpensive TFT that can function as a voltage-controlled pixel switch, which has an electron mobility at least an order of magnitude greater than that of a-Si:H and which can be scaled to large areas, compatible with Gen 10 (or larger) glass processing. LTPS scaling to large areas is difficult and expensive, largely due to the fact that ion implantation and excimer-laser recrystallization is required. Thus, IGZO appears to be a very attractive choice, especially when the off-state performance advantages of IGZO are recognized. However, IGZO is still in an early stage of commercialization, and it is a fair question to ask whether all of the bugs have been worked out yet.

In the literature, the most likely IGZO “bug” that may need to be worked out appears to be the negative-bias illumination-stress (NBIS) instability (involving a threshold-voltage shift to negative voltages for an IGZO TFT subjected to a large negative applied gate voltage and simultaneous near-bandgap optical excitation). The physical mechanism

responsible for the NBIS instability is controversial, but appears to involve the IGZO top surface and/or IGZO subgap electronic states.<sup>1-4,7</sup> Various materials and processing fixes are being explored to control NBIS, such as top-surface passivation and post-deposition annealing. If NBIS cannot be adequately controlled via materials fixes, aggressive light-shielding measures may be required. The fact that Sharp and LG are now shipping IGZO-based products demonstrates that these NBIS challenges can be successfully overcome.

Thus, in deciding between LTPS and IGZO for AMLCD backplane applications, the more attractive choice seems to be IGZO.

**AMLCD or AMOLED?**

Up to now, only AMLCDs have been considered. An LCD pixel is basically a valve that controls the transmitted intensity of light incident from a backlight source, *i.e.*, an LCD is a *non-emissive* (transmissive) display. In contrast, an OLED is an *emissive* display. An emissive display offers many advantages, including wider inherent viewing angle; higher contrast ratios (in dark ambient conditions); faster response time; lower power consumption; and a sleeker, lighter, and thinner form factor. Thus, an AMOLED offers a potentially superior viewing experience.

Recall that an AMLCD backplane pixel is very simple, consisting of a single *voltage-controlled* switch. The architecture of an AMOLED display pixel is more complex because an OLED is a *current-controlled* device. Consequently, active-matrix current control is more difficult to accomplish in an AMOLED display, requiring more than one TFT per pixel. In addition to requiring multiple TFTs to provide the basic current-control function, current-control circuit architectures are very sensitive to variation and drift in TFT parameters, particularly threshold voltage.

The simplest possible AMOLED display pixel architecture consists of two TFTs and one capacitor (2T + 1C) in which one TFT is used for selecting and charging a storage capacitor during addressing while the second TFT functions as a current source to drive the OLED display. An attractive version of the 2T + 1C pixel, as shown in Fig. 4, was proposed by Sony.<sup>8,9</sup> Since Write-Select and Drive-Select lines can be independently controlled, this circuit may be useful in compensating for TFT and/or OLED threshold-voltage drift. Alternatively, other more complex AMOLED

**Table 2:** This comparison of LTPS and IGZO TFTs shows the advantages and disadvantages for both technologies.

Technology	Advantages	Disadvantages
LTPS	Mobility performance CMOS	Ion implantation Excimer-laser recrystallization
IGZO	Cost Large-area scalability Off-state performance	Unproven technology Negative-bias illumination stress

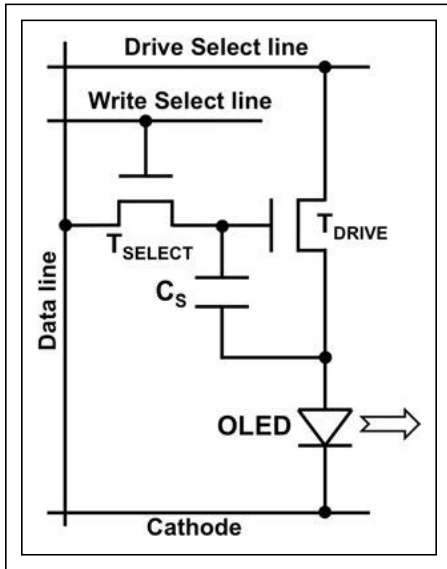

**Fig. 4:** Shown is a two-transistor one-capacitor ( $2T + 1C$ ) AMOLED pixel architecture proposed by Sony in 2012.<sup>8,9</sup>

pixel architectures employing compensation may be required, e.g.,  $4T + 1C$ .<sup>10</sup>

In choosing between AMLCDs and AMOLED displays, pixel architecture appears to be a key factor. If the simple  $2T + 1C$  pixel architecture shown in Fig. 4 provides adequate compensation, then the superior viewing experience offered by AMOLED technology may lead to its eventual dominance. Alternatively, if an appreciably more complex pixel architecture is required for successful AMOLED commercial implementation, it is hard to imagine that AMOLED technology will be able to compete with AMLCD technology. After all, the AMLCD is the flat-panel-display beast, defeating all comers.

AMLCD or AMOLED? Although I am not a betting man (odd, given my last name), if I had to bet, I would go the safe route and choose AMLCD. However, I am rooting for AMOLED! Either way, I prefer IGZO to LTPS because it seems to me that cost will be the main driver, at least for the foreseeable future.

#### Acknowledgments

This article is based on a Keynote Address entitled “Exciting Developments in Oxide TFT Technology,” presented at the Society for Information Display International Symposium

held in Vancouver, Canada, May 21, 2013, and upon work supported by the National Science Foundation under the Center for Chemical Innovation Grant No. CHE-1102637.

#### References

- <sup>1</sup>T. Kamiya, K. Nomura, H. Hosono, “Present status of In-Ga-Zn-O thin-film transistors,” *Sci. Technol. Adv. Mater.* **11**, 1–23 (2010).
- <sup>2</sup>J. K. Jeong, “The status and perspectives of metal oxide thin-film transistors for active matrix flexible displays,” *Semicond. Sci. Technol.* **26**, 034008-1-034008-10 (2011).
- <sup>3</sup>J. S. Park, W-J. Maeng, H-S. Kim, J-S. Park, “Review of recent developments in amorphous oxide semiconductor thin-film transistor devices,” *Thin Solid Films* **520**, 1679–1693 (2012).
- <sup>4</sup>J. F. Wager, B. Yeh, R. L. Hoffman, and D. A. Keszler, “An amorphous oxide semiconductor thin-film transistor approach to oxide electronics,” *J. Curr. Opin. Solid State Mater. Sci.* (in press).
- <sup>5</sup>H. Hosono, M. Yasukawa, H. Kawazoe, “Novel oxide amorphous semiconductors: transparent conducting amorphous oxides,” *J. Non-Cryst. Solids* **203**, 334–344 (1996).
- <sup>6</sup>Sharp, “IGZO: vision for the future,” <http://online.wsj.com/ad/article/vision-breakthrough>
- <sup>7</sup>J. F. Conley, “Instabilities in amorphous oxide semiconductor thin-film transistors,” *IEEE Trans. Device Mat. Rel.* **10**, 460–475 (2010).
- <sup>8</sup>T. Arai, “Oxide-TFT technologies for next-generation AMOLED displays,” *J. Soc. Info. Display* **20**, 156–161 (2012).
- <sup>9</sup>N. Morosawa, Y. Ohshima, M. Morooka, T. Arai, T. Sasaoka, “Novel self-aligned top-gate oxide TFT for AMOLED displays,” *J. Soc. Info. Display* **20**, 47–52 (2012).
- <sup>10</sup>A. Nathan, G. R. Chaji, S. J. Ashtiani, “Driving schemes for a-Si and LPS AMOLED displays,” *J. Display Technol.* **1**, 267–277 (2005). ■

**For Industry News, New Products,  
Current and Forthcoming Articles,  
see [www.informationdisplay.org](http://www.informationdisplay.org)**



## Display Week 2014 Innovation Zone (I-Zone) June 3-4, 2014

At Display Week 2014, the Society for Information Display will provide a forum for live demonstrations of emerging information display technologies in an exhibit called the “Innovation Zone” (I-Zone) in the main Exhibit Hall. The I-Zone will showcase cutting-edge demos and prototypes that will lead to the products of tomorrow.

The I-Zone offers researchers space to demonstrate their prototypes or other hardware demo units for 2 days free of charge at the premier display exhibition in North America and gives attendees a chance to view best-in-class emerging information display technologies in a dedicated area on the show floor. Access to free exhibition space encourages participation by small companies, startups, universities, government labs, and independent research labs.

The I-Zone Selection Committee will evaluate submissions and select the strongest proposals to receive free space within the I-Zone. If their proposal is accepted, applicants must cover their own expenses, including travel, lodging, and the creation of a tabletop exhibit demonstrating their prototypes. In addition, a knowledgeable person must be on hand on Tuesday and Wednesday, June 3–4, while the I-Zone is open to the public to run the demonstration and answer questions.

At Display Week 2014, the I-Zone Committee will select a winner of the “Best Prototype at Display Week” award, to be announced in *Information Display* magazine.

# Everything You Need to Know About Displays (in Four Days)

*The annual technical symposium at Display Week features a mix of breaking news, developments, and predictions from hundreds of key companies and academic institutions that can be found nowhere else.*

by Jenny Donelan

**I**N SAN DIEGO this June, scientists and researchers from all over the world will reveal the year's most important display-industry developments. To anyone who works in displays, or even in an industry touched by displays, the annual International Symposium at Display Week is for a short time the center of the technical universe. It's a one-of-a-kind clearinghouse for all the information that will be essential for carrying on the business of the following year. From the very immediate concerns of which backplane technology to use – oxide TFT or LTPS, for example – to more forward-looking topics such as holographic display systems – they will all be featured in San Diego this spring from June 3–6.

For the purposes of peer review, the papers that will be presented are evaluated by display discipline – Active-Matrix Devices, Applications, Applied Vision/Human Factors, Display Electronics, Display Manufacturing, Display Measurement, Display Systems, Emissive Displays, e-Paper and Flexible Displays, Liquid-Crystal Technology, OLEDs, Projection, Touch and Interactivity – then assigned to sessions designated by topic, such as Electroluminescent Quantum Dots. (This year, five special focus areas were also determined: OLED TV, Wearable Displays, Oxide TFT vs. LTPS, 3D, and Lighting.) Each session con-

sists of 3–5 20-minute paper presentations. The papers chosen to appear at Display Week represent the best of the best. Here are just some of the highlights from this year's sessions:

## **The Back Story on Backplanes**

If there is one dominant theme going into this year's symposium, it is backplanes. Determining which backplane technology is best for a display is not a trivial exercise. Among other considerations, it depends on the display material itself – LCD vs. OLED, for example; and the size – mobile to massive TV. Finding the best one makes a great deal of difference – not only to consumers, in terms of device performance and price, but to companies that make the devices. There are three sessions and 12 papers devoted to the subject of Oxide TFTs vs. LTPS alone this year. Papers that look especially exciting include a late-news paper (one with extremely recent information) from Samsung, entitled “An Advanced ELA for Large-Sized AMOLED Displays.” It describes an Advanced Excimer Laser Annealing process used to make displays such as the 55-in. OLED TV that Samsung introduced last summer. LG also has an interesting late-news paper, on “Roll-to-Roll Processed and Top-Gate Structured a-InGaZnO TFTs with Large Source/Drain Offsets,” which describes a future manufacturing technique for rollable displays.

Another backplane-related topic of interest is quantum dots. This year, there are an

unprecedented three sessions with 13 papers devoted to this subject, from companies including QD Vision, Pacific Light Technologies, 3M, and Sony. QD Vision has recently asserted that quantum dots will enable LCDs to compete with OLED displays to such a degree as to push OLED TVs out of the picture. See if that's possible by checking out QD Vision's paper, “Quantum Dots: The Ultimate Down-Conversion Material for LCDs,” in which the authors, in their words, “make the case that QDs are the ultimate light-generating material for the future of displays.”

## **Onward for OLEDs**

OLEDs are of course an ongoing source of interest for most of the display community. It is a technology whose time has almost come – over and over again. Yet, while the focus has been on TVs all the while, OLEDs have quietly become the foundation for many best-selling mobile devices. This year, both Samsung and LG finally released commercial versions of large OLED TVs (in a curved 55-in. format), which represented a major breakthrough, even though manufacturing challenges remain for large-area OLEDs, and solving those is a point of much of the aforementioned backplane development.

This year's symposium features OLED sessions on devices, flexible OLEDs, materials, OLED driving, lighting, and, of course, TVs. The emphasis for contributed papers of late has been on flexible and TV technology, notes

*Jenny Donelan is the Managing Editor of Information Display magazine. She can be reached at [jdonelan@pcm411.com](mailto:jdonelan@pcm411.com).*



OLED subcommittee chair Sven Murano. With 51 presentations on OLEDs alone, this year's symposium is *the* place to find out what's going on with OLEDs. There are many papers of practical significance, including "Advancements in Ink-Jet Printing for OLED Mass Production" from Kateeva, which describes how to overcome challenges in achieving uniform, mura-free panels, a procedure that is highly dependent on the deposition of uniform ink volumes into each subpixel.

Papers from the two OLED TV sessions are bound to draw plenty of attention, especially as manufacturers AUO, LG, Panasonic, Samsung, and Shenzhen China Star Optoelectronics will all be presenting. "People are looking at questions like 'How do I measure the quality of OLED TV, or how do I compensate for motion artifacts?'" says Murano. "This is something that LCD TV guys know well, and now the OLED guys are looking into these practical questions, which is a good sign – it's all becoming more tangible." Of particular interest is "Advanced Technologies for Large-Sized OLED TV" from LG, which discusses achieving scalability, mass production, and lifetime reliability using oxide TFT, white OLEDs, and solid-phase encapsulation. Another promising paper is "Highly Reliable InGaZnO TFT Backplane for 55-in. 4K × 2K OLED Displays" from Panasonic, which looks at InGaZnO (IGZO) TFT backplanes used to create 55-in. 4K × 2K OLED displays in a Gen 8.5 production line.

### Wearing Your Displays

Wearables are a hot topic in consumer electronics right now, and the symposium features

three wearable-display sessions with a total of 14 papers. The majority of these are about non-flexible displays such as near-to-eye devices, but one session focuses on flexible wearable displays and includes the papers "OLEDs on Textile Substrates with Planarization and Encapsulation Using Multilayers for Wearable Displays," from KAIST, which suggests how OLEDs might be fabricated on textile substrates using a poly(vinyl alcohol) (PVA) multilayer for planarization and encapsulation and "Wearable Display for Dynamic Spatial and Temporal Fashion Trends" from the University of Sunderland, with examples such as a smartphone app-controlled high-heeled shoe that can be programmed to display different imagery (to match an outfit for example (Fig. 1).

### Futuristic Displays: Light-Field and Holography

New this year is an entire session devoted to Light-Field and Multi-View Displays. A paper with perhaps the longest title of the symposium – "Wide-Field-of-View Compressive Light-Field Display Using a Multilayered Architecture and Viewer Tracking" – from MIT is of special interest. In it, the authors describe "a simple extension to existing compressive multilayer light-field displays that greatly extends their field of view and depth of field," ultimately demonstrating a real-time glasses-free 3-D display with a 110 × 45° field of view. Also of interest is "Dual-Layer Three-Dimensional Display with Enhanced Resolution" from Korea's Inha University, which describes a system consisting of two

LC panels with a lenticular lens sheet between them that can present a three-dimensional image without any resolution reduction as compared to a conventional two-view display.

The Holographic Display Systems sessions are also in a "don't miss" category. Holography used to seem futuristic and whimsical, but every year researchers make progress. All this year's sessions are from China, and among them, of special interest is the late-news paper "Waveguide Display System with Variable Output Intensity" from the Beijing Institute of Technology, which describes a method for achieving variable output intensity for holographic images using the holographic gratings.

### Plasma Pioneers

Plasma TVs are no longer as plentiful as they used to be, though many of those still on the market are considered some of the finest TVs available. Without doubt, plasma played an important role in making the flat-panel display industry the success it is today. To mark plasma's impact, on Tuesday afternoon at Display Week, there will be a special 90-minute session following the regular plasma session. Celebration of the "50th Anniversary of the Plasma Display Panel" will feature talks by Professor Donald L. Bitzer, co-inventor of the plasma display panel; Tsutae Shinoda, inventor of color plasma display technology; and former students of Bitzer SID Past-President Larry F. Weber and SID Fellow Roger L. Johnson. Following the session there will be a sponsored reception. This celebration will be a fascinating and no doubt entertaining retrospective of a key display technology and

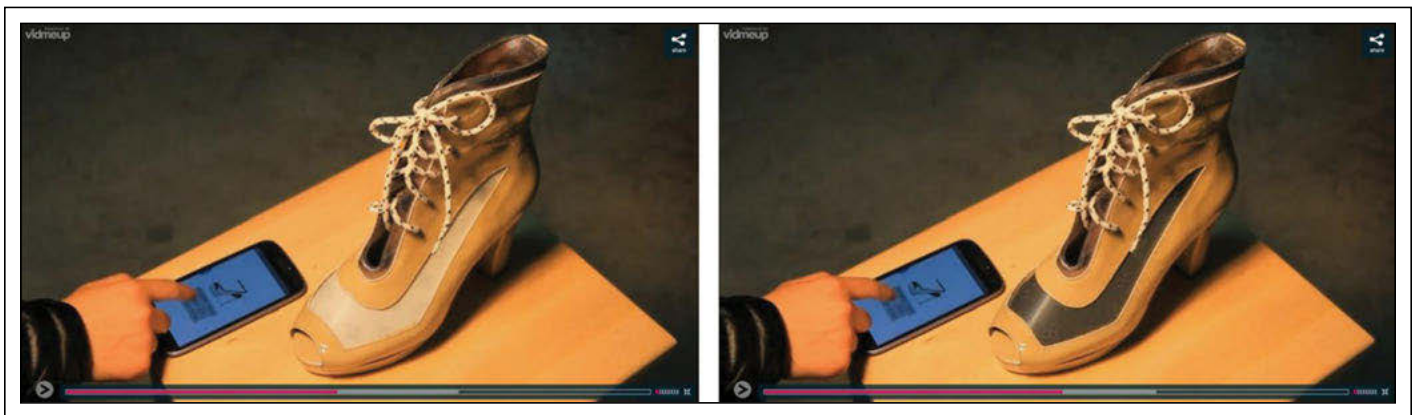

*Fig. 1: A paper from the UK's University of Sunderland describes a shoe embedded with a display that can be programmed from a smartphone to change the appearance of the footwear. Patterned displays are possible as well.*



# Display Week 2014 Symposium at a Glance

2014 SID Display Week Symposium at a Glance – San Diego Convention Center						
Times	Room 6A	Room 6B	Room 1	Room 2	Room 5	Times
SID Business Meeting and Keynote Session (Rooms 6A & 6B)						
8:00 – 10:20 am						8:00 – 10:20 am
10:50 – 12:00 pm	3 Oxide TFTs vs. LTPS I (Joint with Active-Matrix Devices)	4 Display Manufacturing: LCD Materials	5 OLED Devices I	6 Display Manufacturing: Flexible Substrates (Joint with e-Paper/Flexible)	7 Electroluminescent Quantum Dots	10:50 am – 12:10 pm
2:00 – 3:20 pm	8 Oxide TFTs vs. LTPS II (Joint with Active-Matrix Devices)	9 High-Resolution LCDs	10 Flexible OLEDs I	11 Flexible Interactive Devices (Joint with e-Paper/Flexible)	12 Photoluminescent Quantum Dots	2:00 – 3:20 pm
3:40 – 5:00 pm	13 Oxide TFTs vs. LTPS III (Joint with Active-Matrix Devices)	14 Blue-Phase LCDs	15 Flexible OLEDs II	16 Touch Sensor Materials	17 Plasma Displays	3:40 – 5:00 pm
5:00 – 6:00 pm	Author Interviews (Exhibit Hall A)				Special Session 50th Anniversary of the Plasma Display Panel (5:00 - 6:30 pm)	5:00 – 6:00 pm
6:30 – 8:30 pm					Special Networking Event 50th Anniversary Reception (West Terrace)	6:30 – 8:30 pm
<b>Tuesday, June 3</b>						
9:00 – 10:20	18 Wearable Displays I (Wearable Devices)	19 Quantum Dots for LCDs	20 Flexible AMOLEDs I (Joint with e-Paper/Flexible)	21 Display Manufacturing: Oxide TFTs	22 Low-Power and High-Speed Interfaces	9:00 – 10:20 am
10:40 – 12:00	23 Wearable Displays II (Optics Design)	24 Fringe Field Switching / In-Plane Switching	25 Flexible AMOLEDs II (Joint with Active-Matrix Devices)	26 Applications	27 Computational Visual Fidelity	10:40 am – 12:00 pm
2:00 – 3:30 pm	Designated Exhibit Time (Exhibit Hall)					2:00 – 3:30 am
3:30 – 4:50 pm	28 Wearable Displays III (Direct View)	29 Films and Alignment	30 Display Manufacturing: OLEDs	31 Laser Speckle (Joint with Projection)	32 Flexible TFTs	3:30 – 4:50 pm
5:00 – 6:00 pm	Author Interviews (Exhibit Hall A)					5:00 – 6:00 pm
<b>Wednesday, June 4</b>						
9:00 – 10:20 am	33 Active-Matrix TFTs	34 LC Beyond Displays I	35 OLED Materials	36 Light-Field and Multi-View Displays (Joint with Systems)	37 Novel Measurement Standards and Methods	9:00 – 10:20 am
10:40 am – 12:00 pm	38 Capacitive Touch	39 LC Beyond Displays II	40 OLED Devices II	41 Autostereoscopic Systems and Measurement (Joint with Systems and Measurement)	42 Human Vision and Measurements for Lighting Systems (Joint with Measurement and Applied Vision)	10:40 am – 12:00 pm
1:30 – 2:50 pm	43 Novel Interactivity	44 Ultra-High-Resolution Displays	45 OLED Devices III	46 Holographic Display Systems (Joint with Systems and Applications)	47 OLED Lighting I (Joint with OLED)	1:30 – 2:50 pm
3:10 – 4:30 pm	48 Touch Display Manufacturing (Joint with Manufacturing)	49 Active-Matrix Design	50 Advanced OLED Driving	51 Liquid-Crystal Lenses and Doping for 3D (Joint with Liquid-Crystal)	52 OLED Lighting II (Joint with OLED)	3:10 – 4:30 pm
4:30 – 5:30 pm	Author Interviews (Exhibit Hall A)					4:30 – 5:30 pm
5:00 – 8:00 pm	Poster Session (Exhibit Hall A)					5:00 – 8:00 pm
<b>Thursday, June 5</b>						
9:00 – 10:20 am	53 OLED TV I (Joint with OLEDs)	54 e-Paper I	55 Human Factors for 3D Displays (Joint with Applied Vision)	56 Projection Components and System Configurations	57 Advanced Backlighting Technology	9:00 – 10:20 am
10:40 am – 12:00 pm	58 OLED TV II (Joint with OLEDs and Active- Matrix Devices)	59 e-Paper II	60 3D and Augmented-Reality Electronics (Joint with Electronics)	61 Projectors	62 Novel Displays	10:40 am – 12:00 pm
12:00 – 1:00 pm	Author Interviews (Exhibit Hall A)					12:00 – 1:00 pm
<b>Friday, June 6</b>						

## TECHNOLOGY TRACKS KEY

3D	Active-Matrix Devices	Applications	Applied Vision	Display Electronics	Emissive Displays
e-Paper/Flexible	Lighting	Liquid Crystal Technology	Manufacturing	Display Measurement	OLEDs
OLED TV	Oxide TFTs vs. LTPS	Display Systems	Projection	Touch and Interactivity	Wearable Displays

**OCULAR**  
DISPLAY YOUR ADVANTAGE

**CRYSTAL TOUCH: TRUE MULTI-TOUCH  
PROJECTED CAPACITIVE TOUCH PANELS**

[www.ocularlcd.com](http://www.ocularlcd.com)

Ocular is a leading supplier of touch panels and cutting edge display products

**SID  
DISPLAY  
WEEK '14  
SAN DIEGO**

**Visit Ocular at  
SID Display Week  
Booth 721**

## symposium preview

a chance to consider the history of the industry itself. Says Weber, "It's the story of a technology that grew and that still has considerable potential for the future. Young people especially might find it interesting."

### Wrapping It Up

As mentioned previously, it's impossible to describe all the important presentations at Display Week, which include sessions on UHD, novel displays, "Liquid Crystals Beyond Displays," and much more. In addition to 4 days of oral presentations, there is also a Thursday evening poster session, with a huge range of display topics viewable at the same time. *ID* strongly encourages you to download the preliminary program at <http://displayweek.org/2014/Program/Symposium.aspx> and start planning. There's something here for everyone – some of the papers will be invaluable to your work, and some are just plain fascinating – and you will learn things you didn't know you didn't know. One thing is for sure, if you do not visit Display Week to find out for yourself, you'll be missing out on what might be the most useful four days of the entire year. ■



# Display Week 2014

**SID International Symposium,  
Seminar & Exhibition**

**June 1-6, 2014**

**San Diego Convention Center  
San Diego, California, USA**

[www.displayweek.org](http://www.displayweek.org)

**SID**  
SOCIETY FOR INFORMATION DISPLAY

## JOIN SID

We invite you to join SID to participate in shaping the future development of:

- Display technologies and display-related products
- Materials and components for displays and display applications
- Manufacturing processes and equipment
- New markets and applications

In every specialty you will find SID members as leading contributors to their profession.

[http://www.sid.org/  
Membership.aspx](http://www.sid.org/Membership.aspx)

# Optically Clear Adhesives

For Display and Touch Panel Bonding

- High transmission / no yellowing
- Excellent humidity resistance
- Optional 2nd curing mechanism for shadow curing



Visit our website  
[www.DELO.de/en/display-bonding](http://www.DELO.de/en/display-bonding)



# DELO

Leading by intelligent bonding technology

DELO.us • Tel 978.254.5275

COME SEE US AT SID 2014  
San Diego, California  
June 3-5 • Booth # 1808

We bring quality to light.



## Display Test & Measurement

Proven instruments for fast and accurate testing of

- luminance
- chromaticity
- contrast ratio
- viewing angle dependent properties
- homogeneity



- DTS 140 spectroradiometer
- LumiCam 1300 imaging photometer and colorimeter
- DTS 500 positioner

**NEW:** DMS and ConoScope product line from Autronic-Melchers

 **Instrument Systems**  
light measurement

[www.instrumentsystems.com](http://www.instrumentsystems.com)

See Us at Display Week 2014, Booth #1720

# OLED Lighting: The Differentiation Challenge

*In order for OLED lighting to catch up to LED lighting, cost and performance gaps will have to narrow. In the interim, successful lighting companies will capitalize on OLED lighting's unique design attributes.*

by Khasha Ghaffarzadeh

**O**LED DISPLAYS are growing commercially and beginning to take market share away from LCDs, particularly in the area of mobile devices. By contrast, OLED lighting is not doing nearly as well. OLED lighting trails inorganic LEDs in almost every market segment, and therefore has to play catch-up. OLED displays are likely to lose this battle in the short and medium term, given that OLED displays are both under-performing and over-priced.

## Narrowing the Performance Gap

The endgame, however, is promising because customers will buy OLED devices if the cost and performance gap substantially narrows. Lighting companies have little choice but to hedge their bets and stay the course with OLEDs or else risk losing out in the decades to come. In the meantime, these companies need to create stepping stones that generate at least limited cash flow and allow them to accumulate production/marketing experience. In fact, substantial innovation and pressure are building up in the value chain, which will ultimately enable a cost reduction in OLED lighting.

OLED materials will be the first layer in the OLED stack that will experience a rapid cost reduction, and this is based on successes in

*Khasha Ghaffarzadeh is Head of Consulting at IDTechEx, which produces OLED research reports. He can be reached at [khasha@IDTechEx.com](mailto:khasha@IDTechEx.com).*

the OLED-display industry. Even though OLED lighting and display materials have different requirements and operate in different conditions, essential and fundamental similarities exist in material design, chemistry, and production, and OLED-lighting technology can take advantage of these.

This is not to say that OLED-lighting material development lacks challenges. Trade-offs between lifetime and color quality persist, particularly for deep blues (the deeper the

blue, the shorter the lifetime). The material optimization cycle remains expensive and lengthy, despite some major developers having internalized the device prototyping step to shorten the design cycle. OLED lighting materials are also high-tech fine structures incurring high R&D expenditures that inevitably contribute to the final cost.

In the short term, the largest potential for saving material costs is to be found in improving material utilization (currently 10–15%)

**Table 1:** ITO alternative technologies are listed at left and the main players commercializing them are at right. A large supplier base is emerging globally. Source: IDTechEx Transparent Conductive Film Report.

Technology	Companies
Silver nanowires	Cambrios, Carestream Advanced Materials, Showa Denko, Blue Nano, Nanogap, Seashell Technology, Heraeus, Nanotech and Beyond N&B, Sinovia Technologies
Metal mesh	O-film, Uni-Pixel, Epigem, LG Chem, Goss International, PolyIC, Komori, DNP, Gunze, Vast Film, MNTech, Fujifilm, Atmel, Young Fast Optoelectronics, 3M, ELK, LLjin, Hitachi Chemical
PEDOT	Afga Material, Heraeus, Fujitsu, Nagase ChemteX Corporation, Molex, Oji Paper Group Film
Graphene	Bluestone Global Tech, Graphene Laboratories, Cambridge Graphene Platform, Samsung, Sony, Graphene Frontiers
Carbon nanotubes	Canatu, Eikos, Nanointegris, SWENT, Unidym, Brewer Science, Toray Industries, Top Nanosys, XinNano Materials Inc, Nano, Chimei Innolux

**Table 2:** Shown are flexible-barrier technologies (left) and the main players commercializing them (right). Source: IDTechEx

Technology	Companies
Multi-layer	Toppan Printing, 3M, Mitsubishi, Tera Barrier, Toray Industries, Hoslt Centre, Konicak Minolta, UDC, Daicel
Flexible glass	Corning, Schott, Nippon Electric glass

during deposition. Encapsulation and integrated substrates, which include substrate, transparent conductor, and out-coupling layer, are other major cost drivers. The transparent conductive layer must be highly smooth and conductive. However, most suppliers are unwilling to switch capacity to the required indium tin oxide (ITO) grade given the lack of volume and the strength of demand for other ITO grades in, for example, the touch-screen market.

There is, however, substantial activity taking place in the field of transparent conductive films. Here, we will witness a multitude of new technologies competing with ITO on the basis of lower sheet resistance, lower cost, and improved mechanical flexibility. The threat of substitutes and overall high buyer power will ensure that prices fall in the trans-

parent conductive film business, despite the fast rising demand on a global basis. In terms of OLED lighting, the above factors may cause the cost of integrated substrates to fall as well (Table 1).

The same condition occurs when it comes to cavity glass (a glass with a small cavity sandblasted out), which is an excellent encapsulation barrier. Cavity glass works well and meets the technical challenges, but it is expensive. This is partially because the glass industry is reluctant to increase capacity in the absence of clear demand. Flexible versions are also not yet commercially available at the right price or performance point. It should be noted that substantial pressure, mostly from large corporations, is building up within the value chain toward enabling flexible barriers. The strong pull from the OLED-display industry is

strongly incentivizing developers in this field (Table 2).

### The Differentiation Challenge

In the prolonged interim before price parity is approached, OLED lighting will have to capitalize on attributes beyond standard industry figures of merit (*i.e.*, efficacy, cost per km square, and lifetime). Its backers must highlight and exploit the intangible and less concrete “design” or “feel good” parameters. These include color warmth, cold emission, thinness, surface emission, and mechanical flexibility (when flexible barriers become available) (Fig. 1).

It should be noted that LEDs can also create effective surface emission through the use of waveguides. This means that, for example, surface emission is not unique to OLED devices, but that the price and performance gap substantially narrows with OLED versions.

OLED lighting panels can be thought of as luminaires or significant parts of luminaires. This implies that OLED panels will not compete with LED modules, but will do so with LED luminaires, which fetch higher prices. These designations create room, and thus commercial opportunity, for differentiation via custom-designed products at the luminaire level. This custom-design strategy, however, does not sit comfortably with many suppliers who seek to sell high-volume standardized OLED panels (Fig. 2).

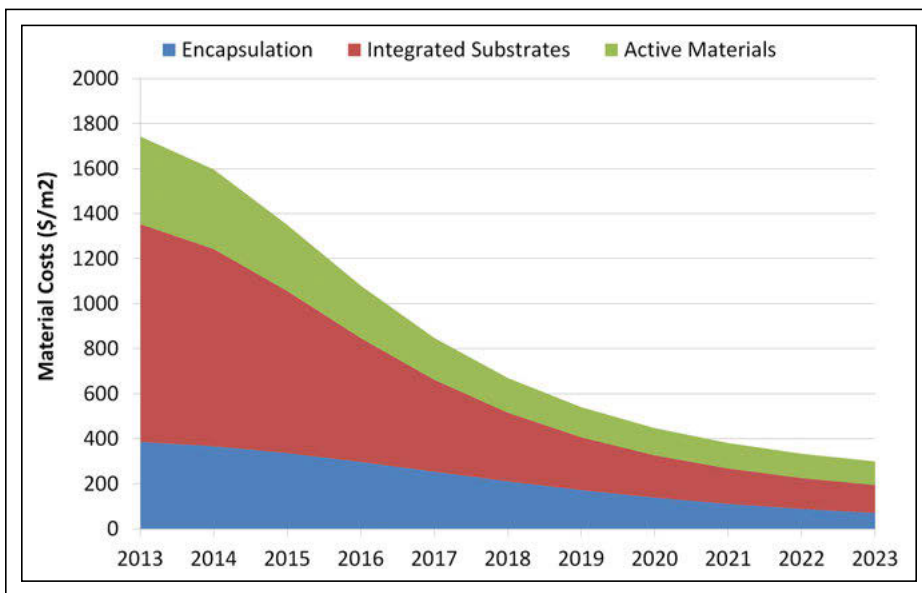

**Fig. 1:** A “most likely” scenario for cost reduction of the bill of materials for a typical OLED stack shows that the cost of materials will decline more rapidly than the costs for encapsulation and integrated substrates. Source: IDTechEx.



**Fig. 2:** LEDs win on standard industry figures of merit such as cost, lifetime, and efficiency, but OLEDs have room for differentiation on the basis of design factors. Source: IDTechEx.

# Display Week 2014

SID International Symposium, Seminar & Exhibition

June 1–6, 2014

San Diego Convention Center  
San Diego, California, USA

## Rolling Out the Red Carpet



### I-Zone

Competition of live demonstrations regarding emerging information-display technologies, such as not-yet-commercialized prototypes and proof of concepts.

### Individual Honors and Awards

The SID Board of Directors, based on recommendations made by the Honors & Awards Committee, grants several annual awards based upon outstanding achievements and significant contributions.

### Display Industry Awards

Each year, the SID awards Gold and Silver Display of the Year Awards in three categories: Display of the Year, Display Application of the Year, and Display Component of the Year.

### Best in Show Awards

The Society for Information Display highlights the most significant new products and technologies shown on the exhibit floor during Display Week.

### *Journal of the Society for Information Display (JSID) Outstanding Student Paper of the Year Award*

Each year a sub-committee of the Editorial Board of *JSID* selects one paper for this award which consists of a plaque and a \$2000 prize.

## display marketplace

### Strategic Challenges

A lack of clear differentiation has created a strategic conundrum for large lighting companies who wish to be competitive in both OLED and LED lighting. On the one hand, they are investing in OLED lighting out of the fear that this technology might ultimately win out and undermine their growing LED business. On the other hand, they cannot give it whole-hearted commercial backing because they cannot sufficiently differentiate it from their existing business lines based on LEDs, and thus fear that it might create an unhealthy and zero-sum internal competition. This strategic confusion is likely to persist as long as clear differentiation is lacking. The lack of differentiation is less of a strategic challenge for companies that are leveraging their OLED-display business to participate in the lighting industry. These companies have every incentive to push their technology hard onto all lighting market segments.

### The Long View

OLED-lighting companies will have to take the long view in order to avoid the commoditization that is sure to overtake LED lighting in the near future, as Asian and particularly Chinese manufacturers put pressure on margins across every level of LED-lighting systems, including lighting module, drivers, *etc.* For OLED lighting, the cost and performance gaps will of course need to narrow, but the key to longer-term success will be capitalizing on OLED's design attributes while closing that gap. OLED-lighting companies will need to ensure technology leadership, in part by maintaining and investing in strong IP. If these criteria can be met, OLED lighting is an attractive long-term proposition, given the size of the global lighting market and the healthy trends sustaining its growth. In the interim, OLED-lighting companies will have to be more than technology leaders; they will have to be good designers too. ■

For Industry News, New Products,  
Current and Forthcoming Articles,  
see [www.informationdisplay.org](http://www.informationdisplay.org)



# Display Week 2014

**International Symposium, Seminar and Exhibition**

**June 1-6, 2014**

**San Diego Convention Center**

**San Diego, California, USA**

Display Week is the once a year, can't-miss event for the electronic information display industry, a \$100 billion/year industry. The exhibition is the premier showcase for global information display companies and researchers to unveil cutting-edge developments in display technology. More display innovations are introduced year after year at Display Week than at any other display event in the world. Display Week is

where the world got its first look at technologies that have shaped the display industry into what it is today.

Display Week is also where emerging industry trends such as 3D, touch and interactivity, flexible and e-paper displays, solid state lighting, digital signage, and plastic electronics are brought to the forefront of the display industry. First looks like these are why over 6,500 attendees will flock to San Diego for Display Week 2014. If your company is involved in

any aspect of displays, including display electronics, components, systems, services, manufacturing equipment, or applications, Display Week 2014 is the place to garner worldwide recognition and grow your business on a global scale.



---

## **Don't forget to check out these events going on during Display Week 2014:**

- ☒ Best in Show & Display Industry Awards Lunch
- ☒ Business Conference
- ☒ International SID Honors & Awards Dinner
- ☒ Investors Conference
- ☒ I-Zone 2014
- ☒ Keynote Speakers
- ☒ Monday Seminars
- ☒ An Evening Reception Aboard the USS Midway
- ☒ Sunday Short Courses
- ☒ Display Week 2014 Symposium placing special emphasis on five Special Topics of Interest: OLED TV, Lighting, Wearable Displays, Oxide vs. LTPS TFTs, and 3D

Photo courtesy of Timothy Hursley



Plaza art outside the San Diego Convention Center

# CES 2014 Display Developments

*This will go down as the year that both UHD and curved displays found commercial traction. It all began with a bang at the annual International Consumer Electronics Show in Las Vegas. And there was even more to see at CES in January – including cars.*

by Steve Sechrist

At CES 2014, displays were at center stage with new technology, larger OLED panel sizes, the proliferation of curved LCD TVs, and even bendable panels that curve to enhance the immersive viewing experience and then flatten to create a picture frame or “artistic” image surface. All this, plus enhanced interactivity and, of course, higher pixel density, were all dominant themes.

Before heading into the details of those displays, it is worth mentioning that an equally impressive highlight of the show was the demonstrated progress in automotive telematic and safety systems – the connected car, which leans heavily on the advanced chip technology previously found more often in phones and game devices. The idea is to bring smartphone features into the car: sharing navigation destinations, other travel information, and media control between smartphone and car. This is a growing trend in the auto-manufacturing space, with an uptick in the number of car makers on the CES show floor. Audi, BMW, Cadillac, Chevrolet, Dodge, Ford, Kia, Mercedes, Tesla, and Toyota all had a significant presence at the event, showing up and showing off just what advanced CPU and GPU chips, navigation, and new on-board sensor systems can bring to the future of driving. And in view, no less than fully connected, were self-piloted vehicles with better situation awareness, shape recognition,

*Steve Sechrist is a display-industry analyst and contributing editor to Information Display magazine. He can be reached at [sechrist@ucla.edu](mailto:sechrist@ucla.edu) or by cell at 503/704-2578.*

vector analysis, and response time than any human can hope to achieve. The car is becoming the ultimate mobile device, and the consumer electronics and auto industries are now tied at the hip going forward.

Back to the display side at CES. Ultra-high-definition (UHD) resolution has gone well beyond a “display trend” and is now elevated to the level of *force majeure*. Never mind the current dearth of content and a delivery package still in development. Further still, the fact that 4K goes beyond the level of human visual acuity also seems to be a non-issue in bringing 4K to market. In short, the UHD display format is not only here but shipping today, with lower prices and growing distribution moving at a hurricane pace. But to understand its full potential we need to look beyond a single UHD picture on the screen.

## 4K Canvas: The Killer App for UHD TVs

On the show floor, vendors were displaying UHD sets with single images in bezel-to-bezel eye-popping color, touting the 4× full-HD capability. But off the floor, in private demonstrations, UHD was being shown as the enabling technology for what vendors are calling the “4K Canvas” (Fig. 1). What this means is using the TV screen as a desktop experience that includes a dominant main display in full HD, with the remainder of those pixels used for smaller images.

The 4K canvas concept was demonstrated in chipmaker Broadcom’s private suite, where the company demonstrated video streaming of not two but four full-HD football games on a

plus-70-in. screen. Broadcom’s Wade Wan told onlookers: “In addition to having 4K video, you can keep your main display in HD, and what operators are excited about is you have a lot more real estate; you have a canvas to work with. Before with HD, when you tried to do picture-in-picture, the second image was very small, or something important on the main display would be covered up.” Broadcom also sees this technology revolutionizing the viewing experience and making all that data from a director’s cut, including outtakes and added screen details, easily available, anytime, even while the a movie scene is playing.

The 4K canvas on a UHD TV can be populated with whatever you like: social media feeds and meta broadcast feeds such as Amazon’s X-Ray service, which links a viewed film to the popular Internet Movie Database (IMBD). With this service, names of actors and other relevant details can be displayed while viewing, with scene information shown outside the main HD image at the click of an on-screen icon. New TVs with a 4K canvas play into the home automation trend as well. As sensors become integrated into the objects around us (see Intel’s project Edison below), the “Internet of things” can be displayed on this 4K canvas. Some analysts speculate that this capability has helped drive Web-based home-automation-vendor Nest to its stellar \$3.2 billion valuation, as well as its ultimate cash acquisition by Google in early 2014. Speaking of Google, more UHD image real estate leaves more room for Internet advertising.

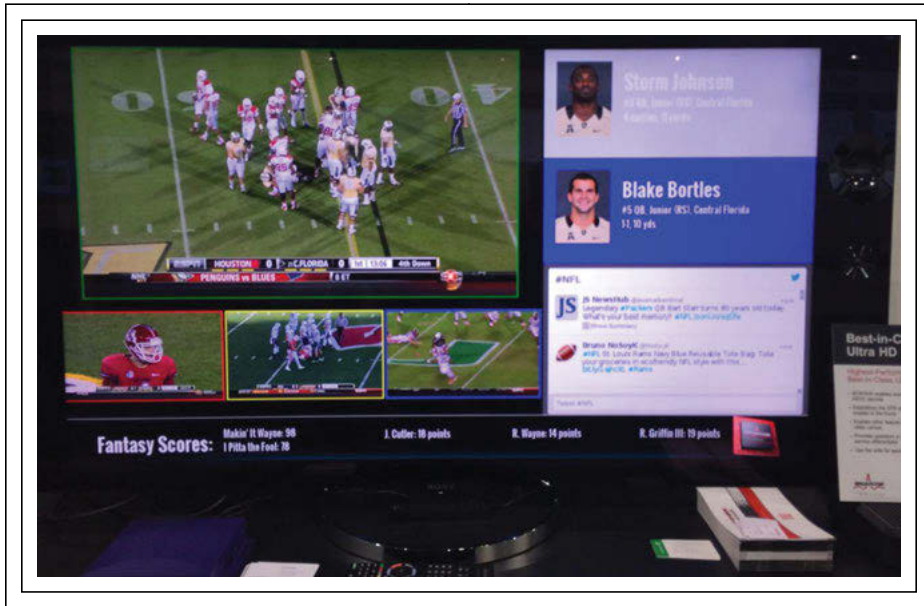

**Fig. 1:** The UHD “Canvas,” shown here in an example from Broadcom, affords multiple video and data streams much like a desktop experience, only on the living-room big screen. Photo courtesy Sechrist 2014.

For its part, Broadcom developed the HEVC (H.265) decoder chips that were first announced at CES 2013, and the company said it was now sampling in quantities to set-top-box makers, pay-TV providers, and even TV OEMs. At this year’s event, Broadcom announced two new low-cost HEVC chips for the entry-level satellite set-top-box market. The systems on a chip (SoC) BCM7364 and BCM7399 use HEVC to achieve up to 50% compression gains that can be used to expand the number of HD channels through the existing infrastructure or expand delivery to include UHD content, according to Broadcom. Expect to see expanded HD channels as the first sign of HEVC penetration into signal distribution, with the eventual switch to UHD image delivery coming later. Among the eye-catching new UHD TV models announced at CES 2014 were 105-in. units from Samsung and LG, TVs ranging from 55 to 120 in. from Sharp, and models from Haier, Panasonic, Sony, TCL, Toshiba, and many others.

### Curved OLED and LCD Screens (Some Bendable) Coming This Year

If UHD was the belle of the CES ball, then curved screens (both OLED and LCD) were the beaux, as most major manufacturers and virtually all China-based suppliers at the show

had curved displays on the floor. This technology is no longer limited to AMOLED TV



**Fig. 2:** The LG G Flex Smartphone with 6-in. curved POLED Display has a “self-healing” back cover. Photo courtesy Sechrist 2014.

displays (as debuted last year at CES), and Samsung went so far as to place its prototype “bendable” LCD into “will ship this year” status.

Samsung’s 85-in. “bendable” prototype that the company says will make it into production (model U9B) in 2014 was shown at its CES press conference. The new LCD-based set uses a remote control to shift from an arched “cinematic” image and back to flat, for ambient viewing of art – among other things. It was among the most exciting demos at the show, and a hoard of reporters mobbed around it at the end of the press conference. The curved 85-in. LCD imagery was stunning, but again, from a prototype, not a full production model. When press members asked Samsung Executive Vice-President Hyun-suk Kim about specific materials and technologies used to make the set, he said that the bendability was achieved through a “materials change.” When asked if this included an ITO replacement such as Cambrios’s silver nanowire, he neither confirmed nor denied it, saying simply: “ITO cannot bend, so we will use a different material.” When asked about the robustness of the bendable set, he said that the model is currently at “multiple-1000-sec MTBF.” And while that’s an important number to pin

down, it does not seem possible to do so yet. Samsung's models may still be undergoing longevity testing that, well, takes time. Kim also confirmed that the set uses some version of glass from Corning. Additional specifications for the bendable display include a 21:9 aspect ratio and a 5120 × 2160 resolution (being referred to as 5K).

LG also had a bendable TV at CES, a 77-in. UHD OLED TV that includes the ability to move from flat to curved using a remote control. LG's unit has the additional capability of allowing the user to set the curvature at various degrees. To date, LG is not revealing any of the science behind its prototype, nor a ship date.

Samsung also showed bendable 55-in.-diagonal OLED sets with UHD resolution at CES, but they were called prototypes, with no plans announced for bringing them to market. The image quality of these TVs was outstanding. Detail, color, and brightness combined for a visceral experience – truly like looking out a window.

Samsung is shifting focus back to LCDs and said as much by what was not shown – no size upgrades to its curved 55-in. OLED TV. Instead, the company will target UHD LCDs in sizes ranging from 50 to 105 in. on the diagonal and announced a new color-gamut extension approach that it will add to its UHD upscaling. The company is also extending its upgrade box technology that should help future-proof sets with both new board electronics and software upgrades to help extend the life of a TV as future advances warrant. No word if this could also serve as a development platform for third-party add-on products.

### No Trouble with the Curve

The move to curved and even bendable TVs by the industry is a significant one – not just a gimmick. One can see noticeable differences when viewing a curved display, even of moderate size. For example, there are no clear reflected images from light behind a curved display, as pointed out by John Taylor at LG. He says (and [DisplayMate.com](#) confirms) that the curve helps diffuse distracting background light, improving overall image quality. And CES was a great place to test out the theory. Recent lab testing by Ray Soneira of DisplayMate found the concave display surface eliminates the “shadow effect” (like one's own reflection) often seen on a flat display surface. Flat displays reflect the

brighter light behind the user at normal viewing distances (see related [sidebar](#), “DisplayMate Testing Confirms Curved Display's Value”).

Bending a display in large or even small format has significant measurable benefits that take the technology way beyond the “hype” claim and into the realm of “high-end” or “top-of-the-line” displays that truly justify a price premium. But beyond all the lab tests and line-item improvements, perhaps most

important to mainstream adoption is that a curved TV set offers a unique form factor and easily discernible upgrade. Much like the sexy thin LED-based LCD TVs that ushered in a wave of high-priced sets just a few years back, curved sets have a must-have look that is sure to drive TV sales upgrades.

### Curves Work on Mobile Screens Too

The LG G Flex display with a self-healing case was first shown in Korea in November,

## DisplayMate Testing Confirms the Value of Curved Displays

Tests from [DisplayMate.com](#) confirm that the concave screen shape used by both LG and Samsung in their curved OLED TVs released last summer “eliminates” reflections from “some” ambient side light simply by using a non-flat surface (with 180° opening angle). The curved screen redirects ambient light behind the viewers, “away from the line of sight.” In his online LG OLED TV Display Technology Shoot-Out, DisplayMate's Ray Soneira raves about the “indistinguishable perfect visual image” (a DisplayMate first) presented by the 55-in. LG set first shown at CES in 2013. Soneira notes: “This is very important for a display technology that produces excellent dark-image content and perfect blacks – because you don't want that spoiled by ambient light reflected off the screen.”

Viewing from an off-axis position to the screen (out of the sweet spot) is better using the concave screen “... because the curved screen accommodates their viewing direction better and reduces the stretched keystone (trapezoidal) shaped image that is seen with flat screens viewed at an angle from the sides,” writes Soneira in his Shoot-Out. The trade-off is a slight or “subtle geometric effect,” quantified by Soneira as a 1.5% curve, made up of the difference between the center and the sides that is discernible from a viewing distance of about 2.4 m (8 ft.)

Curved screens in smaller hand-held sizes also gain benefits, according to Soneira. In his tests with the curved Galaxy Round held at normal viewing distances, “... your face is magnified so that it always fills the entire screen so that you don't see the much brighter light coming from behind you. As a result, there is typically a large reduction of reflected ambient light, both indoors and especially outdoors,” he explains. This is particularly important because ambient outdoor viewing of LCDs is considered by some to be the technology's Achilles' heel. Although the Galaxy Round is an OLED display, presumably the curvature could benefit LCD-based mobile devices as well.

Soneira also found the curved screen magnifies the user's face in the horizontal by a factor of >2×. This magnification contributes to reduced brightness of the reflected image, now being “spread out by the magnification.” Due to magnification, the curved screen offers properties of natural reflectance reduction (with no filters or additional layers added.)

Reduced visual interference of reflected images on the mobile display is the third benefit that slightly curved displays gain from the magnification effect. This comes about as viewing distance increases beyond the focal distance (or about 8 in.), blurring the reflected visual object rather than just making it smaller as on a flat-surface display. This blurred effect renders the image “... featureless and effectively invisible,” according to Soneira, and that “significantly reduces the visual interference from the screen reflections.”

then publicly displayed at CES in January 2014 (Fig. 2). It features a 6-in. POLED display that can “flex” to a flat position with some pressure (such as being sat on in your back pocket), the company said. The device also has a self-healing back, and at the show LG personnel were using blunt tools to mark up its back, only to have it “heal” as we watched. It’s a nice compliment to the Gorilla Glass display that prevents scratches to the screen side of the phone. The width on the G Flex is 81.6 mm compared to the iPhone’s 58.6 mm, but the almost 30% wider form-factor size was mitigated by the curved screen. It really was quite comfortable in the hand.

The curved surface also seemed to improve the displayed image as the background light was obscured, and there was no “cosmetic mirror” effect (see the sidebar for DisplayMate’s

comments on the value of a mobile curved display).

### Content is Still King and 4K Is Coming

On the 4K content side, a pre-CES announcement by Netflix saying it will deliver (at no extra charge) a 4K version of its home-grown drama series *House of Cards* was just the beginning. At CES, major TV brands, including LG, Samsung, Sony, and Vizio, stated they will integrate the new Netflix app and its HEVC 4K decoding technology directly into new UHD sets. Netflix said delivery will require over 15 Mbps (15.6 Mbps) in bandwidth, pushing the limits of home delivery of the UHD signal.

Amazon also announced partnerships with major studios Warner, Lionsgate, 20th Century Fox, and Discovery for 4K content. The

studio arm of Amazon (Amazon Studios) announced in December a commitment to 4K production on all programming going forward. Samsung also included Amazon (and Paramount Studios) on its list of UHD-content partner companies, so look for the Amazon Prime service nested in new Samsung sets as well.

Meanwhile, Sony has its own UHD streaming service, Video Unlimited, as part of the Sony Entertainment Network. The group said it will expand to around 140 titles (film and TV) with UHD playback capability. At the press conference, the company announced a live TV streaming content service but gave few details beyond testing that will start in the U.S. sometime this year. This is a subscription-based service and an added source of revenue for Sony Entertainment group.

Beyond the studios and over-the-top (via Internet) providers, both Comcast and DirecTV will offer 4K content to subscribers. Comcast’s 4K Xfinity App is already working on Samsung UHD sets and allows over-the-top (OTT) streaming at 4K resolutions via On Demand. For now, the solution is exclusive to Samsung. On the cable set-top-box side, Comcast said its new X1 STB is 4K capable and will ship later this year. DirecTV paid lip service to 4K content, but few details were forthcoming. It’s interesting to note that in UHD, it’s OTT that’s delivering the goods better than can conventional satellite and cable delivery that require more than just software upgrades but a whole new codec (HEVC) to get the job done.

### UHD Upscaling Empowers UHD Adoption

One final word on content and that is the all-important upscaling from HD to UHD. The display manufacturers leaned heavily on upscaling at CES because of lack of original content. The problem is reminiscent of the early HD transition days at the CES and NAB shows of the past, with the same limited HD content loops playing in almost every show booth. But not this year, and this is partly due to Technicolor’s certification that targets HD to UHD upscaling. The company is known more for its color-motion-picture process that dates back to the 1920s, and also for its more recent broadcast engineering. Now it is moving downstream, certifying devices such as TVs with a developed series of technologies that up-convert images to match native UHD



**Fig. 3:** Dell’s new low-cost 28-in.-diagonal UHD monitor with a TN-LCD was scheduled to start selling in Q1 for just \$699, with 1.07 billion colors, 170° viewing angle, and 5-msec response time. Source: Forbsimg.com.

## show review

working at the pixel and frame level to deliver the goods. The algorithms are licensed to chip-level providers who integrate then earn the Technicolor certification and can be used by set-top-box or other device makers such as Toshiba's BD-X 6400 media box and Blu-ray players shown at CES. Both offer the Marseille video-processing chip from Marseille Networks, with algorithms licensed from Technicolor.

### UHD Monitors at CES Include New 28-in. Size from Multiple Vendors

The low cost of 4K monitors (starting at \$499) debuting at CES 2014 was somewhat stunning and important because the new lower price point will help serve as a gateway technology for UHD into the home in 2014. Desktop-

monitor makers include Dell, Philips, and three Chinese brands (Lenovo, Seiki, and Asus). All featured a common 28-in.-diagonal size, suggesting the use of the same LCD panel maker. That fab is unidentified, but the display is of the twisted-nematic (TN) technology vintage (as opposed to the more popular IPS.) Also suspected are a-Si rather than zinc-oxide backplanes and edge lighting rather than direct LED lighting. The price/feature trade-offs will become more evident as the full-UHD display and chipset specifications become known.

These costs went as low as \$499 for the Seiki, \$699 for the Dell P2815Q (Fig. 3) and Asus PB278Q, and \$700 for the Lenovo Pro2840m. The other lower-cost UHD display came from Philips (Brilliance 288p). It sells

for \$1199 but offers a 10-bit color palette at 60 Hz and, like the Lenovo, has a swivel-stand option that moves from landscape to portrait mode.

In all, CES was a watershed for low-cost UHD desktop monitors that can serve as gateways for UHD into the home, particularly when used for gaming.

### Wearables at CES Lacked Flexibility

Beyond TVs, flexible displays were a no-show in the wearable category at CES. The wearables that appeared all used the same rigid glass in mostly square form factors. In addition to the Sony shown in Fig. 4, new smartwatch designs appearing at CES included:

- Metawatch's Meta, a high-end addition to its line that includes a square, high-res color display and leather and metal wristband options.
- The Archos smartwatch, which uses Bluetooth to connect to Android devices using an E Ink display that curves nicely around the wrist and offers up to 10 days of battery life.
- Sonostar's smartwatch that uses the same type of E Ink model with a curved 1.73-in. display that will start selling in Q1 for \$179.
- A line of smartwatches from Kreyos, which seems to be getting a bit closer, that offer both gesture and voice command and the tag line, "Keep your phone in your pocket." The watches allow users to answer and make calls, with texting and notification as well as activity and fitness tracking. The display is a 144 × 168-pixel LCD with 7-day battery life.
- The Neptune Pine, which looks like a (really small) tablet on the wrist, with a 2.4-in. color QVGA touch display (320 × 240), Qualcomm S4 processor (dual core), and up to 32 GB of memory. It runs Android 4.1 (Jelly Bean) and will sell with fitness attachments. The company said its built-in processor and cell network chips make Bluetooth tethering unnecessary (it's a smartphone you wear on your wrist). Other features include a front-facing and rear-facing camera and the ability to run gaming apps.

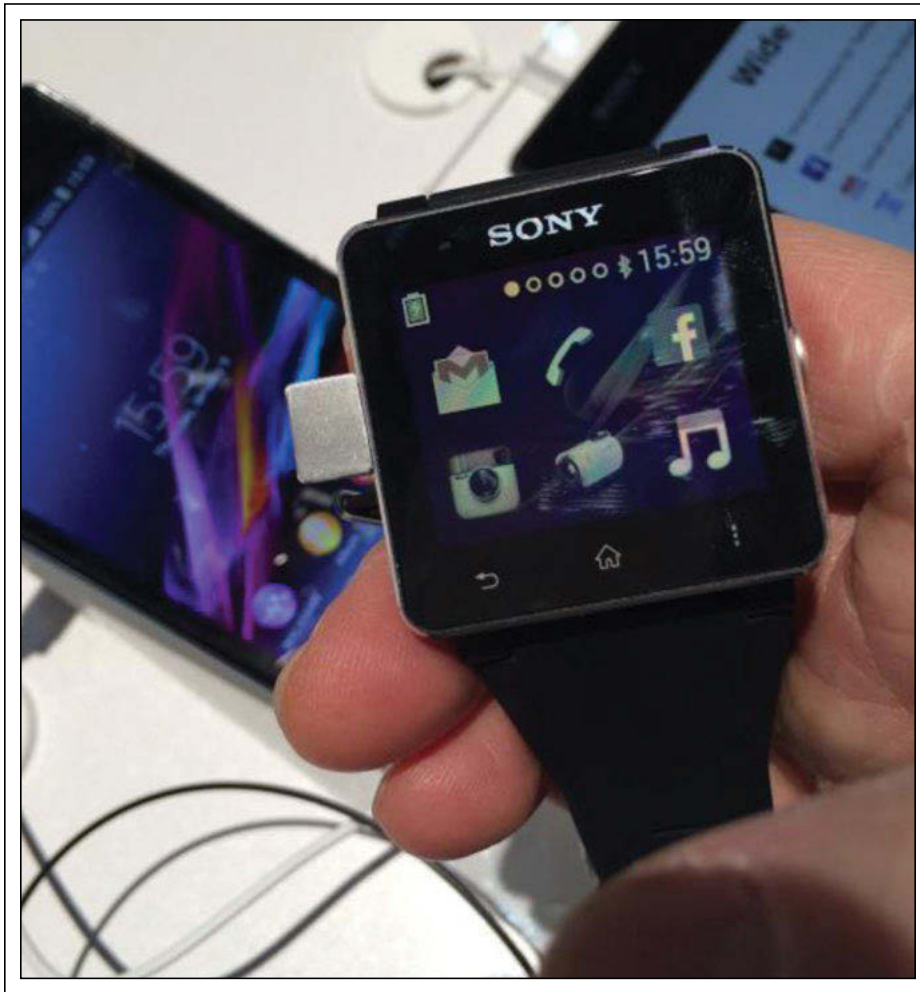

*Fig. 4: The rigid glass Sony Smartwatch2 showed no flexible screen update at CES 2014. The wearable device connects with a variety of apps and new sensors developed by Sony.*

### The Internet of Things: Intel's Non-Tethered Perceptual Computing

While wearable technology such as a smart-

watch is usually thought of as extending the connectivity of the smartphone in your pocket to your wrist, at CES, Intel introduced its take on wearables and the so-called Internet of things. The buzzwords are “non-tethered” and “perceptual computing” (use of gestures, facial recognition, and voice for control.) Both are to be powered by Intel’s new chip project, Edison. This is a new mobile SoC platform introduced at a CES Keynote by Intel CEO Brian Krzanich, along with prototypes for developers, to illustrate the potential of its Intel-chip-based technology.

Features include an Intel 22-nm Quark-technology-based computer with an SD-card package with built-in wireless to simplify connectivity plus Bluetooth LE and memory options that include LPDDR2 and NAND flash storage, and a 3-D camera module (RealSense brand). Intel said its Edison will

serve as a programmable microcontroller and ×86 processor core (dual core) and run Linux with support for multiple OSes. So the plan is that Intel will go mobile with its non-tethered device powered by the highly mobile Quark processor, Edison package, and perceptual computing with 3-D camera technology for mobile applications. Its move into wearables and “perceptual computing” is a marked shift in the direction of leadership rather than following the smartphone and tablet space, and an arguably worthy one from the world’s largest chip maker. The company is sampling chips now with a viable software development kit (SKD) available from Intel.

So, with the hurricane winds of UHD blowing at CES, developments in both 4K resolution and curved sets dominated, with flexible and curved mobile displays perhaps waiting in the wings for later this year. Top chipmakers

such as Broadcom and Intel are moving rapidly in the space with new initiatives to capture the 4K HEVC delivery and non-tethered mobile trends in the wearable/Internet of things space, respectively. On the automotive side, top car makers with new systems on display are pushing boundaries of both safety and convenience and even promising piloted vehicles designed to make the rush-hour drive home stress free and crowded downtown parking a non-event.

Look for 2014 to be the year UHD becomes a reality that moves into the mainstream with curved and even bendable sets at the high end. Wearables will have to wait until the flexible displays make their way into new mobile products to be announced in subsequent quarters. For now, CES 2014 showed that displays and the multiverse of industries they touch are getting off to a great start. ■

**XENARC**

Transportation Management

Marine

Point of Sale

Gaming and Digital Signage

System Integration

Medical

**WHY LEAVE YOUR DISPLAY SOLUTIONS TO CHANCE?**

Xenarc Technologies has a full line of display solutions customizable to any need. [www.xenarc.com](http://www.xenarc.com) 888.656.6536

See Us at Display Week 2014, Booth #626

## Quantum-Dot LEDs' Victory over OLED TV Predicted, Debated at Advanced TV Conference

by Ken Werner

In his presentation at a recent conference on advanced TV technologies hosted by the Society for Information Display's Los Angeles chapter, Seth Coe-Sullivan (co-founder and CTO of QD Vision) made a well-argued case that OLED TV will become irrelevant in 5 years. In that time frame, he predicted, conventional white LED (WLED) backlit LCD-TV will still be going strong, and quantum-dot-enhanced blue-LED-backlit TVs will be a major presence in the market place.

Coe-Sullivan (Fig. 1) was one of several industry experts who presented thought-provoking and sometimes conflicting views on the future direction of TV technology at SID LA's "One-Day Conference on Technologies for Advanced Television," held in Costa Mesa, California, on February 7, 2014. The conference was the 11th hosted by the chapter and was designed to provide display-industry professionals with opportunities for education, discussion, and networking.

According to Coe-Sullivan, the TV technology that will follow the above-mentioned LCD variations will be quantum-dot LED



**Fig. 1:** Seth Coe-Sullivan, co-founder and CTO of QD Vision, created a stir at the recent LA Chapter conference by predicting the demise of OLED TV. (Photo courtesy Ken Werner)

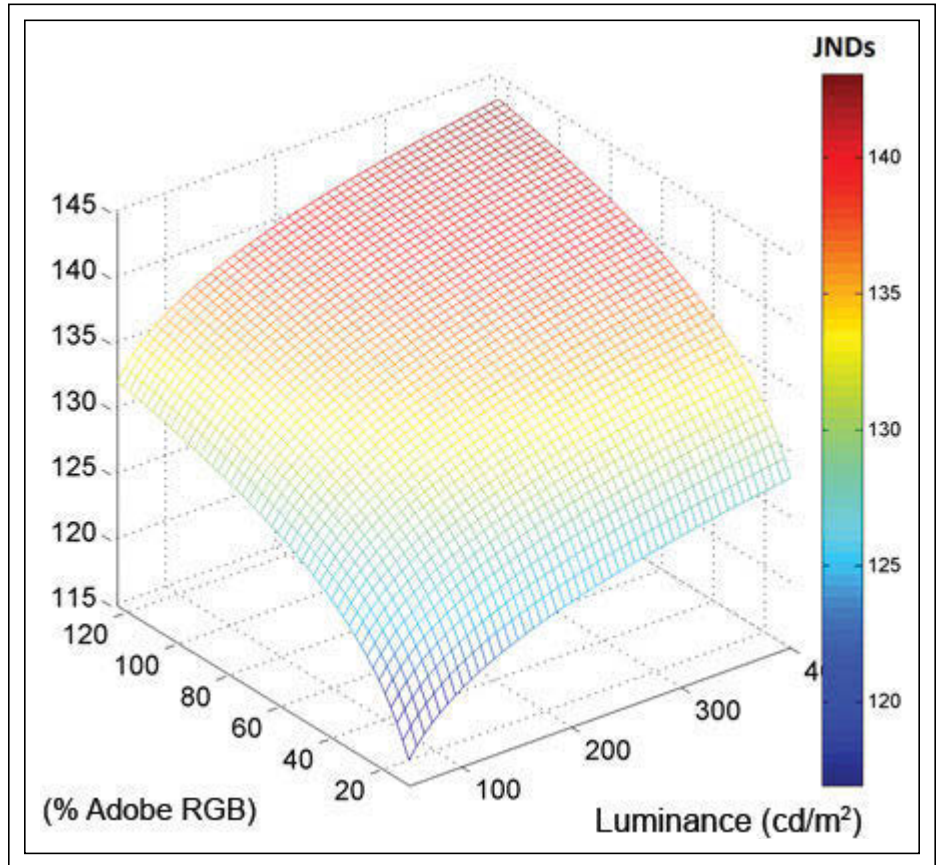

**Fig. 2:** Extensive development and testing have gone into 3M's Display Quality Score. This is an example involving luminance. (Image courtesy 3M)

(QLED) technology, which has the same general structure as OLED technology but with quantum dots as the emissive layer instead of organic light-emitting materials. Coe-Sullivan's argument was based on the ability of quantum-dot-enhanced LCDs to provide better color gamut than OLED displays and also to reduce power consumption, all at a minimal increase in cost. Coe-Sullivan systematically countered all but one of the arguments made in OLED TV's favor – its very high contrast ratio in a darkened room.

One of OLED TV's problems has been cost, which has kept its market penetration low. Although not widely recognized by the general public, quantum dots appeared in major products in 2013: three models of Sony television (in the U.S.), which use QD Vision's Color IQ rail, and one of Amazon's new Kindle Fire HDX models, which uses 3M's quantum-dot enhancement film (QDEF). Coe-Sullivan, 3M's Erik Jostes, and Touch

Display Research's Jennifer Colegrove all predicted a rapid growth in design wins for quantum dots in 2014, with increasingly rapid growth coming in 2015 and following years.

Coe-Sullivan's case was well laid out and generated a very lively Q&A session, but none of the other speakers, including 3M's Jostes, defied the conventional wisdom that predicts OLED TV's continuing growth. In addition to discussing quantum dots in general and QDEF in particular, Jostes spent a significant amount of time discussing which display characteristics viewers respond to most strongly. To make prediction of display-quality preferences easier, 3M has developed a single metric, the Display Quality Score (DQS), which incorporates the usual individual metrics – resolution, viewing distance, display size, color gamut, and contrast – as well as the relative importance viewers give these metrics in actual testing (Fig. 2). (For more about 3M's quality metrics, see the article "PQM: A Quantitative



Tool for Evaluating Decisions in Display Design,” in the May/June 2013 issue of *Information Display* magazine.)

The metric has been verified in validation studies. Resolution has the biggest impact on DQS, and color has the second biggest impact, according to Jostes, who also said, “people generally prefer high saturation to fidelity.” Jostes also noted that at a 14-in. viewing distance, improvements in DQS top out at about 500 ppi, which has clear implications for how much pixel density makes sense in tablets, phablets, and smartphones.

Ho Kyoong Chung, in “Why is OLED-TV Taking So Long,” countered Coe-Sullivan’s arguments about OLED TV’s eventual success, making the case that OLED TV’s problems are being resolved. Chung, Chair Professor at Sungkyunkwan University and Director of the Samsung SMD OLED Center at the university, was formerly Executive VP at Samsung SMD and exhibited an impressive depth of knowledge about OLED technology and manufacturing issues, as well as a genial style of presenting what he knows.

Chung concluded that OLED TV has suffered from significant yield issues that are now in the process of being resolved. He commented that LG Display probably had a 10% yield for TV panels in the middle of last year, and probably now has a 50% yield.

Low yield is one of the things that keeps costs (and prices) high, and price is the main thing that is slowing OLED TV’s market penetration. Another issue is that processing costs, apart from yield, remain high. However, said Chung, OLED-TV manufacturing technology will converge to standard techniques, such as white OLED plus color filter and fabrication by printing. With convergence and scale-up, the cost of manufacturing OLED TVs can be less than that for LCD TVs, he maintained. He concluded by saying the critical innovation for low-cost OLED manufacturing will be roll-to-roll manufacturing and rollable TV.

At the moment, it is ultra-high-definition, or 4K × 2K, television that is moving the TV market. Some analysts are waving red flags, saying that lack of conveniently available native 4K content will put the brakes on UHD sales, as lack of 3-D content in part put the brakes on 3-D viewing. But in “Technicolor 4K Image Certification,” Technicolor’s Kirk Barker outlined the algorithms that implement very-high-quality 2K-to-4K up-scaling, and

Technicolor’s program for certifying the efficiency of chips and end-user products that implement such algorithms. Barker noted that in side-by-side tests at CES and elsewhere, analysts and journalists often mistakenly select the up-converted image over the native 4K image. As a participant in more than one of the tests, yours truly can support Barker’s report.

Sharp Electronics has made IGZO metal-oxide TFTs a commercial success in high-pixel-density LCDs, but there are still complications in applying them to OLED TVs, as LG Display has discovered, although yields are reportedly rising. Sharp Senior Product Marketing Manager Dave Hagan explained how IGZO not only supports high pixel density in LCDs, but also enables power saving and more-effective touch panels because it supports a less-noisy backplane than does amorphous silicon (Fig. 3).

The original attraction of metal-oxide TFTs was that the amorphous version offered almost as much carrier mobility as the crystalline state. But now we have seen that the amorphous version has stability problems. Hagan suggested that Sharp is developing a crystalline structure that will further stabilize IGZO and support displays with over 500 ppi. The new material has higher electron mobility and supports lower power consumption than the current amorphous material.

In addition to IGZO’s use in LCDs and OLED displays, Hagan noted its application in the Pixtronix in-plane MEMS display that

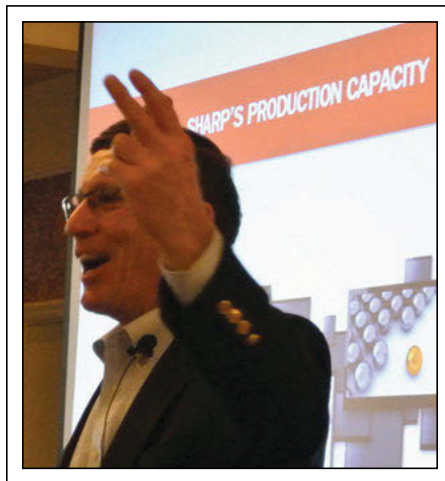

*Fig. 3: Sharp's Dave Hagan did not hide his enthusiasm for the company's IGZO-based displays. (Photo courtesy Ken Werner)*

has been under development for some time. Hagan suggested that we may see a commercial product from Pixtronix in the second half of this year. There may be more definitive information at SID’s Display Week, where Sharp and Qualcomm/Pixtronix will almost certainly be exhibiting.

SID LA’s One-Day Conference on Technologies for Advanced Television was characterized not only by high-quality speakers who presented effectively, but also by a high-quality audience that sustained spirited and good-natured interaction with the speakers. The format, well-honed over 11 conferences, also provides comfortable opportunities for conversation and networking. ■

*Ken Werner is the founder and principal of Nutmeg Consultants and was the program chair and moderator for the one-day conference. He can be reached at [kwerner@nutmegconsultants.com](mailto:kwerner@nutmegconsultants.com).*

**SID**  
SOCIETY FOR INFORMATION DISPLAY

**JOIN SID**

We invite you to join SID to participate in shaping the future development of:

- Display technologies and display-related products
- Materials and components for displays and display applications
- Manufacturing processes and equipment
- New markets and applications

In every specialty you will find SID members as leading contributors to their profession.

<http://www.sid.org/Membership.aspx>

*continued from page 2*

electronics sort of snuck up on us over the past year, when we first started hearing about people actually attempting to use paper as a substrate for active semiconductors. Paper electronics are not the same as electronic paper. The latter is a widely understood alternative for paper that is the subject of extensive research using a variety of display, backplane, and substrate technologies. Paper electronics refers to a nascent but growing effort to actually create electronic circuits and display topologies on paper – yes, cellulose pulp-style paper. In their Frontline Technology article titled “The Future is Paper-Based,” authors Rodrigo Martins, Luis Pereira, and Elvira Fortunato describe the many exciting opportunities for paper-based electronics and displays, along with the current state of the art and what is likely coming soon in terms of new research work. I don’t think this story will persuade you to hold your breath waiting for this technology to emerge in the short term, but it did convince me that the field of research is viable and the commercial opportunity is worth the effort.

On the subject of backplanes, we never wait very long for more news these days, and there are always a lot of questions about the commercial impact of each new advancement. It seems that everyone is working on some type of innovation or improvement on this very basic but critical architectural component of virtually all electronic displays. You’ve no doubt heard the latest news about commercial adoption of both oxide and LTPS technology into OLED TV panels. Well, with the help of our guest editor Dr. Adi Abileah, we convinced author and professor John Wager from Oregon State University to give us a complete update on the state of the art in both IGZO and LTPS technologies. We came away believing both technologies have a long future in both AMOLED and AMLCD applications. We’re grateful to Dr. Abileah, a longstanding supporter of SID and *ID* magazine, for helping us assemble this issue and we hope you will enjoy reading his Guest Editorial, “A Short History of Backplane Technology.”

Backplane technology is also a dominant theme of this year’s International Symposium at Display Week, and after you finish John Wager’s article you’ll be primed to get the most out of the three full sessions and 12 new papers devoted to this very same topic – exploring the merits of oxide and LTPS TFTs. Backplanes are just one part of the amazing

array of technical sessions at the symposium, which cover everything from quantum dots to wearable displays. The paper highlights are carefully previewed for you this month by Jenny Donelan in her feature, “Everything You Need to Know About Displays (in Four Days).” I’m especially interested in the light-field and holography papers, especially after all the coverage we’ve had here in *ID* on these topics over the past couple of years. It’s a rapidly moving area of research and soon to be yet another development that leaves people asking: “Where did that come from?”

We had quite a bit of excitement this issue when display metrology expert Ed Kelley came to us with the second part of his Frontline Technology series on the optical performance of curved OLED TVs, this time focusing on reflection measurements. Ed made a rather surprising discovery during his measurement investigation, and it will have at least some impact on the next generation of IDMS reflection measurements. I’d love to reveal the surprise but I’ll save it for Ed in his article titled “Considering Reflection Performance in Curved OLED TVs.”

We’ve also talked quite a bit about OLED technology for lighting, both at SID events and in this magazine. The question always comes down to: When will it happen? And: How will they get there? Author Khasha Ghaffarzadeh from IDTechEx takes his best shot at answering these questions in his Display Marketplace feature, “OLED Lighting: The Differentiation Challenge.” Khasha talks about the challenging dynamic of the marketplace, where technology is commoditized almost the instant it becomes commercially viable. Given the huge potential market for OLED lighting products, there will be a lot of market dynamics at play over the next few years. However, as Khasha shows us, there is a viable path to cost reductions that will bring this technology into the mainstream, and there are some strategies manufacturers can adopt to at least partially protect themselves from the relentless attack of commoditization at the same time.

Earlier this year, there were two other interesting industry events that started things off with renewed excitement for displays. The first was the annual Consumer Electronics Show (CES) in Las Vegas, where the display headlines were Ultra-High Definition (UHD) and curved displays including some that were bendable – yes, with an adjustable bending

angle. We were a bit skeptical of the pre-show publicity, so to make sure we got the real story we sent longtime contributor Steve Sechrist on a mission to chronicle all the important display happenings at CES. Steve returned with some great revelations which I’m sure you’ll enjoy, and we truly appreciate all his effort on our behalf.

Also in February, the LA Chapter of SID kicked off its “One-Day Conference on Technologies for Advanced Television.” Former New England Chapter supporter Seth Coe-Sullivan, co-founder and CTO of QD Vision, boldly predicted the early demise of OLED TV! Fortunately, chair and conference moderator Ken Werner was able to report back to us first hand on all the details. In his SID News feature titled “Quantum-Dot LED’s Victory over OLED TV Predicted, Debated at Advanced TV Conference,” Ken describes the whole story behind the bold quantum-dot victory declaration and numerous other key topics discussed and roundly debated at this event. I’m glad Ken was there to help us set the record straight.

And so, as we all look forward to the promise of a little warm weather soon, we wrap up this issue of *Information Display* and hope it gives you something to enjoy ahead of your upcoming trip to San Diego. I look forward to seeing all my friends and colleagues from the industry there! ■

**VISIT  
INFORMATION  
DISPLAY ON-LINE**

**For daily display  
industry news**

**[www.informationdisplay.org](http://www.informationdisplay.org)**

continued from page 3

commercially available the second half of this year. Specific partners have not yet been announced.

### Radiant Zemax Adds New Imaging Colorimeter

The ProMetric I2 from Radiant Zemax is the company's latest imaging colorimeter. It is designed for high-volume production lines and uses a scientific-grade 2MP (1600 × 1200) CCD sensor that is thermoelectrically cooled to provide accurate, repeatable 12-bit measurements (Fig. 3). The device is suited to applications such as color and luminance uniformity testing in flat-panel displays (FPDs), light measurement and characterization of LED products, and other test and measurement applications requiring speed, flexibility, and seamless operation. According to Radiant Zemax, it combines the benefits of automation – speed, flexibility, and repeatability – with the relevancy and accuracy of human visual perception.



Fig. 3: The Prometric I2 colorimeter from Radiant Zemax has a thermoelectrically cooled sensor to provide accurate, repeatable 12-bit measurements.

For daily display industry news, visit [www.informationdisplay.org](http://www.informationdisplay.org)

continued from page 4

crystalline (LTPS)] processes. John's article is well-explained, and I hope that you will enjoy reading it. It nicely outlines the trade-offs that are necessary as new materials and processes continue to develop and impact each other. ■

*Adi Abileah recently retired from Planar Systems, where he served as the chief scientist for the Technology Group. His main activity was related to the development of active-matrix liquid-crystal displays (AMLCDs), the physics and optics of displays based on several technologies, and backlights and enhancement techniques. He can be reached at [adi@adi-displays.com](mailto:adi@adi-displays.com).*

### Submit Your News Releases

Please send all press releases and new product announcements to:

Jenny Donelan  
*Information Display Magazine*  
 411 Lafayette Street, Suite 201  
 New York, NY 10003  
 Fax: 212.460.5460  
 e-mail: [jdonelan@pcm411.com](mailto:jdonelan@pcm411.com)

VISIT  
 INFORMATION  
 DISPLAY ON-LINE

[www.informationdisplay.org](http://www.informationdisplay.org)



# Display Week 2014

SID International Symposium,  
 Seminar & Exhibition

June 1-6, 2014

San Diego Convention Center  
 San Diego, California, USA

[www.displayweek.org](http://www.displayweek.org)



# Information DISPLAY

Official Monthly Publication of the Society for Information Display



## 2014 EDITORIAL CALENDAR

### ■ January/February

**Flexible Technology, e-Paper, and Novel Materials**

Special Features: Color e-Paper Update, Materials Market Study

Related Technologies and Markets: e-Paper, OLEDs, glass, films, coatings, manufacturing, MEMs, nanoparticles

**Jan 3:** Ad closing

### ■ March/April

**Display Week Preview, OLEDs, Backplanes**

Special Features: Symposium Preview, SID Honors and Awards, Display Week at a Glance

Related Technologies and Markets: OLED TVs, Flexible OLEDs, backplanes, mobile displays, oxide TFT

**Mar 13:** Ad closing

### ■ May/June

**Display Week Show Issue, Wearable Displays**

Special Features: Display of the Year Awards, Products on Display

Related Technologies and Markets: Head-up Displays, OLEDs, LCDs, Military

**May 5:** Ad closing

### ■ July/August

**Interactivity/Touch/Tracking, Tablets**

Special Features: Tablet Market Study, Interactivity Update

Related Technologies and Markets: ITO, backplanes, tablets, glass, films

**June 30:** Ad closing

### ■ September/October

**Display Week Wrap-up, Manufacturing**

Special Features: Display Week Technology Reviews, Best in Show and Innovation Awards

Related Technologies and Markets: Manufacturing, Metrology, Materials

**Aug 25:** Ad closing

### ■ November/December

**3D/Holography, Television**

Special Features: Consumer TV Roundup, State-of-the-Art 3D Survey

Related Technologies and Markets: OLEDs, LCDs, TVs, Retail Electronics

**Oct. 24:** Ad closing

Contact:

Roland Espinosa

**INFORMATION DISPLAY MAGAZINE**

Advertising Representative

Phone: 201-748-6819 • Email: [respinosa@wiley.com](mailto:respinosa@wiley.com)

View the Information Display Website: [www.informationdisplay.org](http://www.informationdisplay.org)

# sustaining members

Abrisa Technologies  
**AGC Asahi Glass (Silver Member)**  
 Applied Nanotech  
 AU Optronics Corp.  
  
 Canatu  
 Cima Nanotech  
 CLEARink Displays  
 Corning Holding Japan  
**Corning Incorporated (Gold Member)**  
  
 Dawar Technologies, Inc.  
 DisplaySearch  
**Dontech (Silver Member)**  
  
**Eldim (Gold Member)**  
 Elo TouchSystems  
 eMagin Corp.  
 Endicott Research Group  
 Epoxy Technology  
 EuropTec USA  
  
 Focal Tech Systems  
  
**Henkel (China) Investment Co., Ltd. (Gold Member)**  
  
 IGNIS Innovation Inc.  
 Industrial Technology Research Institute  
**Instrument Systems (Gold Member)**  
 I-PEX  
  
 Japan Display, Inc.  
 Japan Patent Office

Lintec  
 LMS Global  
 Luminix  
  
 Merck Display Technologies Ltd.  
 Mitsubishi Chemical Corp.  
 Mitsubishi Electric Corp.  
  
 NANOSYS  
 NDF Special Light Products, B.V.  
 NEC Corp.  
 NextWindow  
 Noritake Itron Corp.  
**Novald (Silver Member)**  
  
 Ocular  
 Optical Filters (USA)  
 Optoma Europe  
  
 Panasonic Corp.  
**Radiant Zemax (Gold Member)**  
 Rolic Technologies  
  
 Sartomer USA LLC  
 Sharp Corp.  
 Shenzhen Leaguer Optronics Co., Ltd.  
  
 Tannas Electronics  
 Tatsuta Electric Wire & Cable Co.  
 Teijin Dupont Films Japan Ltd.  
 TFD, Inc.  
  
 Vestel Electronics A.S.  
  
 Westar Display Technologies, Inc.  
 WINTEK Corp.

# index to advertisers

Corning Incorporated .....	19	Instrument Systems .....	35
DELO .....	35	Ocular .....	34
Display Week 2014 .....	39	Radiant Zemax .....	C2
Electronic Assembly .....	52	TFD .....	C3
Henkel Corp. ....	C4	Xenarc Technologies Corp. ....	45
Information Display .....	5,25,51	Xenon Corp. ....	5

## Sales Office

Joseph Tomaszewski  
 Advertising Sales Manager  
 Wiley  
 111 River Street  
 Hoboken, NJ 07030  
 201-748-8895  
 jtomaszews@wiley.com

## Advertising Sales Representative

Roland Espinosa  
 Wiley  
 111 River Street  
 Hoboken, NJ 07030  
 201-748-6819  
 respinosa@wiley.com

## ELECTRONIC ASSEMBLY

new display design

### Display Solutions

- COG Displays
- Touch Panels
- Control Units
- Intelligent Displays
- RS-232 / I<sup>2</sup>C / SPI
- USB Evaluationboard
- German Engineering since 1977



Distributed by



**ELECTRONIC ASSEMBLY GmbH**  
 sales@lcd-module.com  
 www.lcd-module.com

**MOUSER ELECTRONICS**  
 www.mouser.com

# NATURE'S THIN FILMS LET YOU SEE...

## OUR THIN FILMS MAKE WHAT YOU SEE

## LOOK BETTER

### SMOOTHEST TCO'S:

ITO (Indium Tin Oxide)  
IZO (Indium Zinc Oxide)  
FTO (Fluorine Tin Oxide)

Nanotubes, Nanoparticles  
AZO (Al Doped Zinc Oxide)  
SnO<sub>2</sub>:Cu (Cu Doped Tin Oxide)  
In<sub>2</sub>O<sub>3</sub>:Ag, InO<sub>3</sub>:Au

- ▶ Stock Coated Gen 2.5 Glass: I.T.O., IMITO™, (Broadband AR) at Extremely Low Prices
- ▶ ITO: 60, 20, 10 & 4 ohm/Sq.
- ▶ IMITO™: 60, 20, 10 & 4 ohm/Sq.

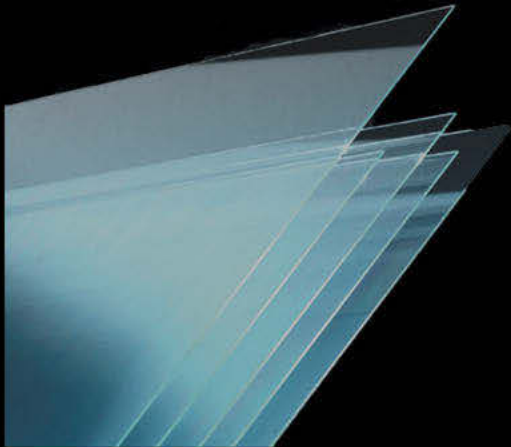

STANDARD ITO - 1.30 x 1.80 m<sup>2</sup>

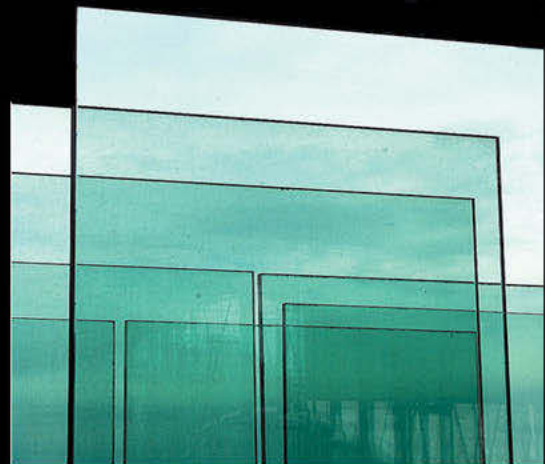

IMITO™ TO AIR - 1.30 X 1.80 m<sup>2</sup>

- ▶ Grid Pattern with IMITO™ ≤ 5 μm wide lines to 0.1 ohm/sq. with T% ≥ 90% (400 nm – 3 μm)
- ▶ EMI & Heater - Multilayer Structure on same side – T% ≥ 92% (400 - 700 nm)
- ▶ Patterning: High Volume - Gen. 2.5 Etch Line for ITO, IMITO™ & Metals (MAM) & Others

### Display Products (All Ion Beam Sputtered):

- ▶ IMITO™ to LC, Epoxy & Air
- ▶ EMI/EMP Shield & Heaters
- ▶ Filters, & BBAR: One Sided or Both Sides
- ▶ Anti-Reflective, Hot Mirrors & Cold Mirrors

Over 60 Materials Developed For Thin Films



## Thin Film Devices, Incorporated

1180 N. Tustin Avenue, Anaheim, CA 92807

Phone: 714-630-7127 · Fax: 714-630-7119 · Email: Sales@tfdinc.com

Visit our website: [www.tfdinc.com](http://www.tfdinc.com)

China Mfg:  
Group International  
+86-75-8270-7053

Korean Mfg:  
Ion-Tek  
+82-2-375-1423

Taiwan Mfg:  
Acrosense Tech  
+86-6-601-6388

See Us at Display Week 2014, Booth #1520

**LOCTITE®**



SHADOW AREA  
FPCB and Ink pattern

**LOCA**

**THE PRIMER CURING PROCESS**

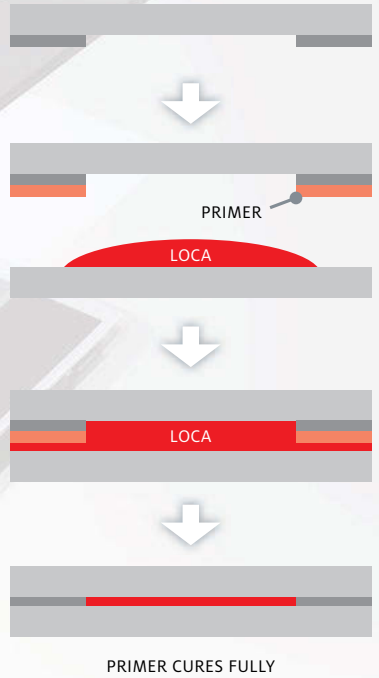

# Shadow Curing. Solved.

LOCTITE® Liquid Optically Clear Adhesives

LOCTITE® 3196PR, Primer Curing LOCAs provides key benefits:

- Cure any area regardless of light penetration
- Easily integrated into existing lamination processes
- Eliminates the need for secondary curing equipment



Excellence is our Passion

[www.loctite.com/loca](http://www.loctite.com/loca) • [loctite.loca@henkel.com](mailto:loctite.loca@henkel.com) • Telephone: China: +86-21-2891 8000 • Japan: +81-45-758 1800 • Korea: +82-2-3279 1700 • Taiwan: +886-2-2227 1988

See Us at Display Week 2014, Booth #1311